

July 1, 1958

O. H. CARLISLE

2,841,084

TOY ROCKET

Filed Aug. 30, 1954

2 Sheets-Sheet 1

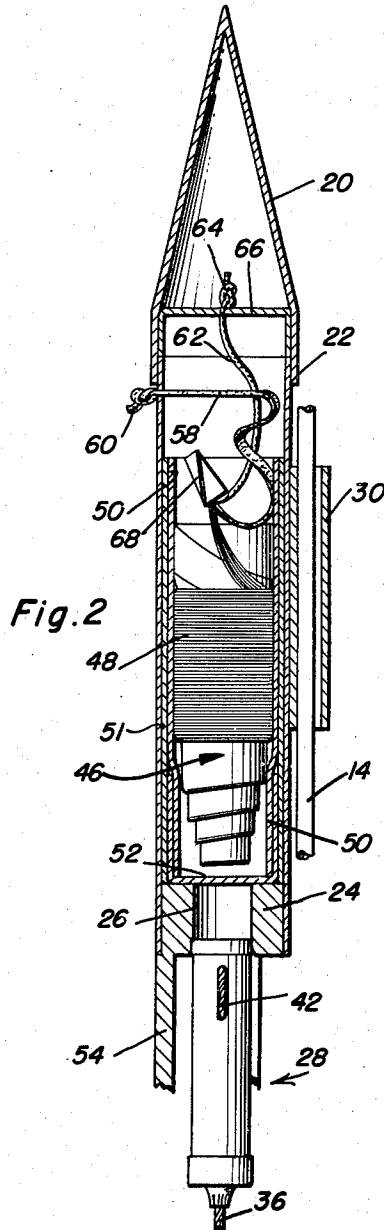
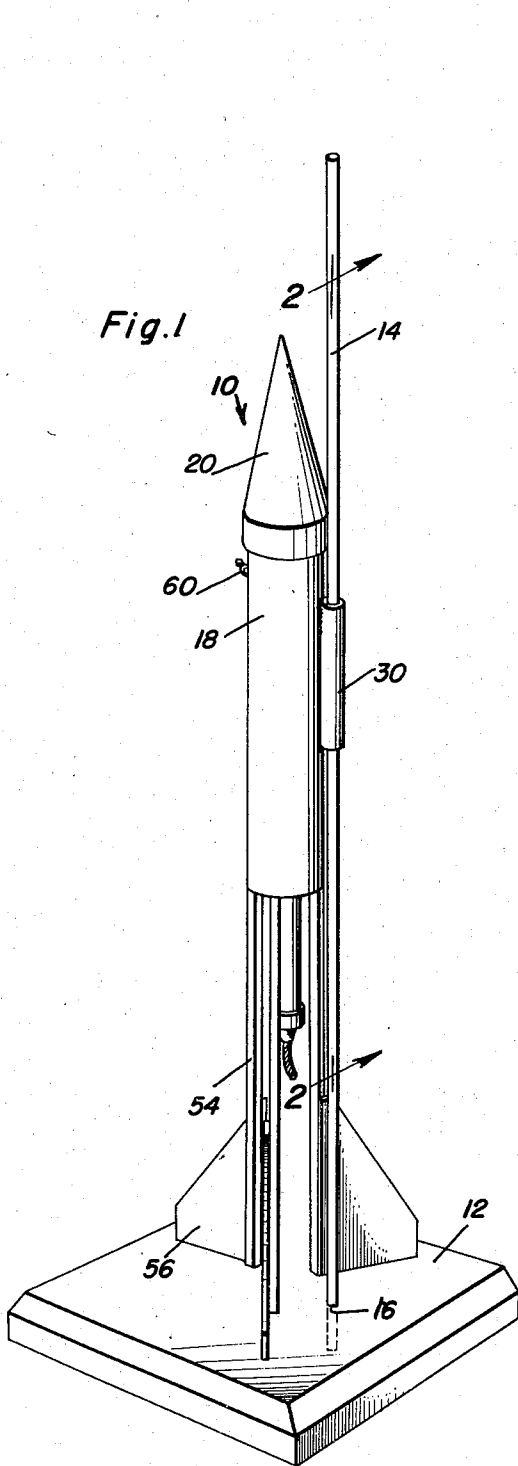

Orville H. Carlisle
INVENTOR.

BY *Almon W. Dixon*
and *Harvey R. Jackson*
Attorneys

July 1, 1958

O. H. CARLISLE

2,841,084

TOY ROCKET

Filed Aug. 30, 1954

2 Sheets-Sheet 2

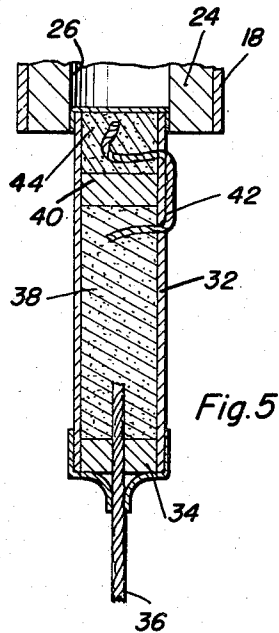
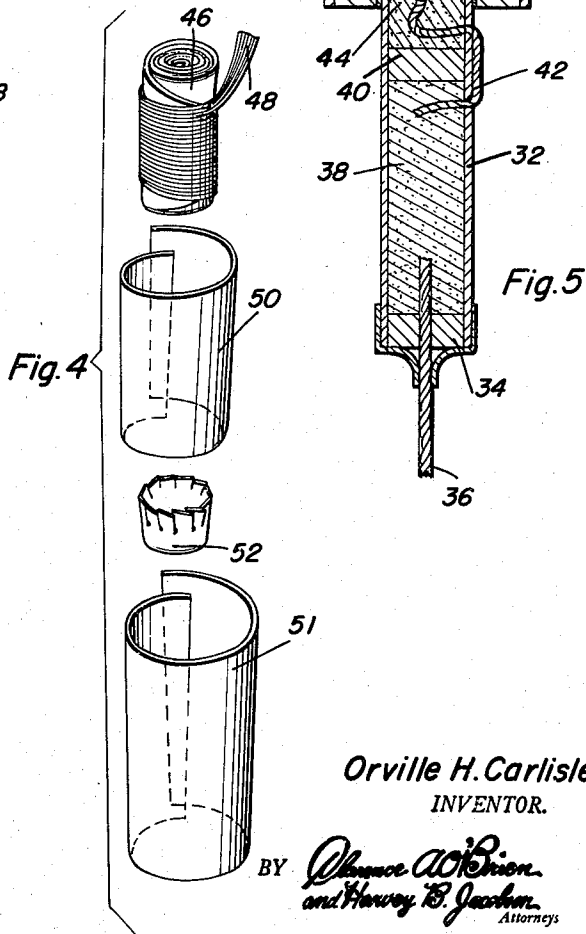
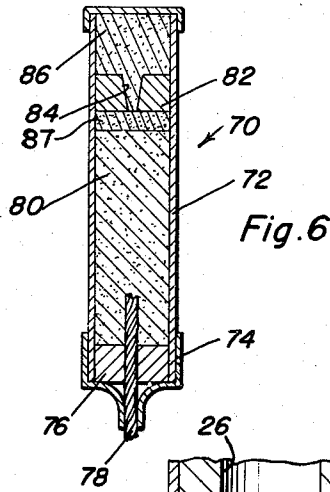
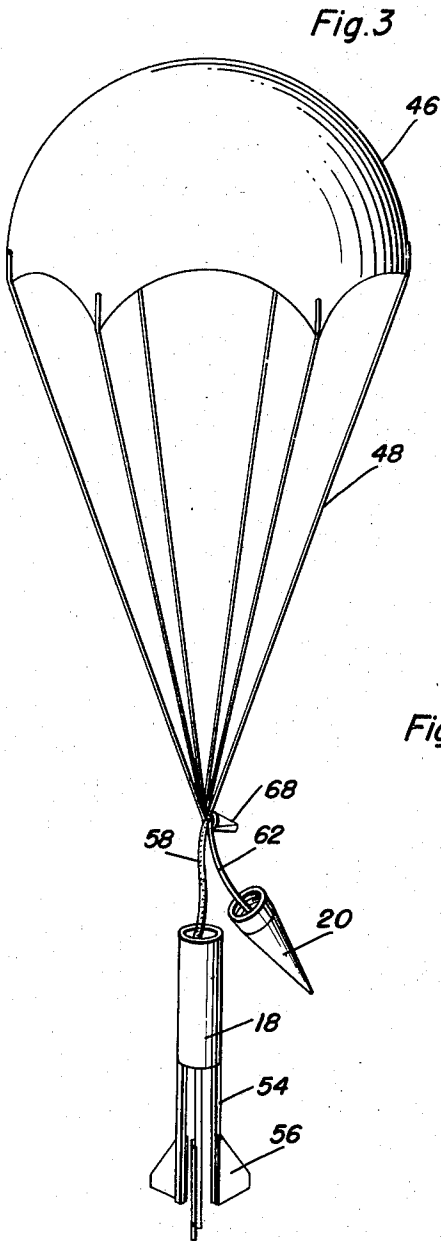

Orville H. Carlisle
INVENTOR.

BY *Albance A. O'Brien*
and Harvey B. Jackson
Attorneys

1

2,841,084

TOY ROCKET

Orville H. Carlisle, Norfolk, Nebr.

Application August 30, 1954, Serial No. 453,085

5 Claims. (Cl. 102—34.1)

This invention relates to a toy rocket and more specifically provides novel and improved construction in a toy rocket, its launching ramp, means for retarding its descent and improved propelling means for propelling the rocket into the air.

An object of this invention is to provide a toy rocket having a tubular housing with one removable end together with a parachute folded within the tubular housing for permitting slow descent of the rocket after it has reached the upper limit of its ascent.

Another object of the present invention is to provide a toy rocket having improved propelling means, such as a combustible mixture together with a secondary combustible mixture that will expel the parachute out of the tubular housing and open it for lowering the housing in a relatively slow manner as the housing is attached to the parachute.

Yet another important object of the present invention is to provide a toy rocket having an improved means for propelling the rocket and expelling a parachute wherein the parachute will be protected from damage by the expelling charge.

A still further object of the present invention is to provide a toy rocket having a replaceable cartridge for the propelling and parachute expelling means together with a folded parachute for placement within the rocket wherein the major portions of the rocket are reusable.

Other important objects of the present invention will be found in its simplicity of construction, ease of operation, novelty in construction, long lasting qualities, its adaptability for its intended purpose and inexpensive manufacture.

These together with other objects and advantages which will become subsequently apparent reside in the details of construction and operation as more fully hereinafter described and claimed, reference being had to the accompanying drawings forming a part hereof, wherein like numerals refer to like parts throughout, and in which:

Figure 1 is a perspective view showing the rocket of the present invention in position for launching;

Figure 2 is a longitudinal, vertical sectional view taken substantially upon the plane passing along section line 2—2 of Figure 1 showing the details of construction of the interior of the rocket;

Figure 3 is a perspective view showing the rocket of the present invention with the parachute unfolded and the rocket being slowly lowered to the ground by the parachute;

Figure 4 is a group perspective view showing the parachute in folded condition, the parachute wrapper, liner and the end cap for positioning between the parachute and the parachute expelling charge and between the liner and wrapper;

Figure 5 is a longitudinal, sectional view taken along the longitudinal center line of one type of replaceable cartridge utilized in the rocket of the present invention; and

2

Figure 6 is a longitudinal sectional view similar to Figure 5 showing a modified form of replaceable cartridge showing the two sections wherein one section is provided for expelling the parachute and the other section provided for propelling the rocket into the air and showing the means for igniting the expelling portion of the cartridge after the propelling portion has been exhausted.

Referring now specifically to the drawing, it will be seen that the numeral 10 generally designates the toy rocket of the present invention including a base 12 having an upstanding standard 14 removably positioned thereon in an aperture 16 wherein the base 12 and the standard 14 form a launching ramp for the toy rocket 10. The detachable connection between the upstanding standard 14 and the base 12 permits the standard 14 to be removed and placed alongside the base 12 for shipment or storage in a compact condition.

The toy rocket 10 includes a generally elongated tubular cylindrical housing 18 having a removable conical upper end 20 forming a removable closure cap wherein the conical member 20 has a depending peripheral flange 22 slidably and telescopically engaged with the upper end of the tubular member or housing 18.

The lower end of the tubular housing 18 is provided with an annular plug 24 having an aperture 26 therein for detachably receiving a replaceable cartridge 28.

A tubular sleeve 30 is positioned on one side of the housing 18 for slidable engagement over the vertical standard 14 for guiding the initial movement of the rocket 18 thereby guiding the ascent of the rocket 18, as the rocket is forced upwardly into the air by the use of the propelling charge in the cartridge 28.

The cartridge 28 as illustrated in Figure 5 includes a tubular cylindrical housing 32 having a plug 34 in one end with a fuse 36 extending outwardly therefrom and a combustible mixture 38 therein. A plug 40 divides the upper end of the cartridge casing 32 into another compartment and a fuse 42 joins the combustible mixture 38 with an explosive or combustible mixture 44 in the upper section whereby the upper section having the explosive mixture 44 therein will be ignited through the fuse 42 when and after the propelling combustible mixture 38 is completely exhausted. The upper combustible mixture 44 is for a purpose described hereinafter.

Referring now specifically to Figure 2, it will be seen that a parachute generally designated by the numeral 46 is rolled into a small cylindrical package with a plurality of shroud lines 48 wound thereabout and a paper cover or wrapper 50 is positioned around the entire parachute 46 and the lines 48 and positioned in the housing 18 after a liner 51 has been inserted therein.

An end cap 52 is provided in surrounding relation to the lower end of the cover or wrapper 50 and the end cap 52 rests against the upper edge of the plug 24 wherein the parachute 46 will be protected from damage by the explosive charge 44 in the upper end of the cartridge 28.

Extending downwardly from the bottom end of the tubular housing 18 is a plurality of peripherally spaced elongated rods 54 having outwardly projected guide fins 56 on the remote ends thereof for stabilizing the flight of the toy rocket during its ascent.

The shroud lines 48 of the parachute 46 are connected to a resilient member 58 that is secured to an edge of the rocket housing 18 by providing a knot 60 on the outer end thereof and extending the resilient member through the side wall of the housing 18. The shroud lines 48 are also secured to a flexible line 62 connected to the conical cap 20 by a knot 64 passed through an aperture in a baffle wall 66 integral with the conical cap 20. It will be seen in Figures 2 and 3 that the shroud lines 48, resilient member 58 and the flexible line 62 are connected together by a connector 68 and the conical cap 20 and

housing 18 are secured to the shroud lines 48 whereby the parachute 46 will lower the cap and housing for reuse.

Referring now specifically to Figure 6, it will be seen that a modified form of cartridge 28 is designated by the numeral 70 and includes a tubular housing 72 having a cap 74 on the lower end with a plug 76 therein having a fuse 78 passed therethrough for igniting a propelling charge of combustible mixture 80. A plug 82 is positioned in the upper end of the casing 72 and the plug 82 is provided with an aperture 84 providing communication to an explosive charge 86 used for expelling the parachute 46 from the housing 18. It will be seen that the expelling charge 86 is not ignited until the propelling charge 80 is completely exhausted. This arrangement will permit the rocket, when launched in a vertical plane, to reach its upper limit of ascent and as the propelling charge 80 is exhausted the expelling charge 86 will be ignited thereby exploding and expelling the parachute 46 from the tubular housing 18 wherein the tubular housing 18 along with the conical member 20 will be lowered to the ground by utilizing the parachute 46. The expelling charge 86 fills aperture 84 and includes a small quantity 87 below plug 82 for assuring ignition thereof.

In operation, the liner 51 is first placed in the housing 18 for preventing the inside surface of the housing 18 from becoming charred and corroded by the action of the exploding charges 44 or 86 and then the parachute 46 is folded and rolled into a cylindrical package and the shroud lines 48 are wound therearound and the entire device is then positioned in the wrapper 50 and end cap 52 positioned over the lower end of the wrapper 50 and the entire device inserted into the liner 51 which is disposed in the tubular housing 18. A cartridge 28 or 70 is then inserted in the aperture 26 in the plug 24 and the fuse ignited after the sleeve 30 has been positioned over the vertical standard 14. The exhaust of the gases formed by the combustible mixture 38 or 80 will urge the rocket 10 upwardly into the air and after the propelling charges 38 or 80 have been exhausted, the expelling charges 44 or 86 will be ignited thereby expelling the parachute 46 from the tubular housing 18 and permitting parachute 46 to lower the tubular housing 18 and the conical member 20 downwardly to the ground thereby permitting reuse of the tubular housing 18 and the conical member 20 after the parachute 46 has been refolded. Upon each use of the rocket 10, the liner 51 and wrapper 50 are replaced along with the end cap 52. Also, a new cartridge 28 or 70 must be used for each time the rocket 10 is used. It will be seen that the end cap 52 effectively prevents damage to the parachute and wrapper 50 that would normally be caused by the exploding of the expelling charge 44 or 86 and the liner 51 prevents damage to the inside of the housing 18 and provides smooth passage for the parachute, wrapper and end cap.

It will be seen that the present device provides a novel and highly desirable toy rocket wherein the main components of the device are reusable and some skill will be developed in the refolding of the parachute 46 after each use of the rocket 10. The housing 18 and the conical member 20 may be constructed of suitable cardboard or paper board or any other suitable relatively inexpensive material.

From the foregoing, the construction and operation of the device will be readily understood and further explanation is believed to be unnecessary. However, since numerous modifications and changes will readily occur to those skilled in the art, it is not desired to limit the invention to the exact construction shown and described, and accordingly, all suitable modifications and equivalents may be resorted to, falling within the scope of the appended claims.

What is claimed as new is as follows:

1. A toy rocket comprising, a housing, guide fins on

said housing, propelling means in said housing for projecting the rocket into the air, and timed means in said housing for retarding the descent of said rocket, said timed means being actuated after the propelling means has been expended, said housing having a removable cap, a paper liner in said housing for preventing charring and corrosion of the inside surface thereof, a folded parachute in said housing, said parachute having shroud lines, a resilient member secured to an edge of said housing and connected with the shroud lines, said resilient member absorbing the shock caused by the opening of the parachute, said parachute being extended into its unfolded condition by said timed means during descent of said rocket, said folded parachute formed substantially in the form of a cylinder, and an end cap positioned on one end of said folded parachute, said timed means including an explosive charge for expelling the parachute from the housing said folded parachute having a paper wrapper, an end cap on one end thereof for protecting said parachute from damage by the explosive charge, said liner end cap and wrapper being expendable, said liner also providing a smooth surface for the expelling of the parachute, wrapper and end cap.

2. A toy rocket adapted for vertical launching comprising a hollow housing having guide fins thereon, the upper end of said housing having a removable closure cap thereon, a parachute, shroud lines on said parachute, means anchoring the free ends of the shroud lines to the housing and closure cap, said parachute and shroud lines being folded into substantially a cylindrical package and disposed within the housing, a wrapper for said package for retaining the parachute and shroud lines folded, an end cap for said wrapper forming a closure for the lower end of said package, a propelling charge mounted on the lower end of the housing, said propelling charge including a replaceable cartridge, the lower end of the housing having an aperture therethrough for receiving the upper end of the cartridge, said cartridge including a combustible mixture in the lower end thereof for propelling the housing, and an explosive mixture in the upper end thereof, means permitting ignition of the combustible mixture from the bottom thereof whereby the propelling combustible mixture will be consumed before ignition of the explosive mixture, the ignition of the explosive mixture forcing the end cap, wrapper, parachute and closure cap outwardly of the housing whereby the parachute will be unfolded with the housing and closure cap being suspended from the shroud lines, the ignition of the explosive mixture after consumption of the propelling combustible mixture assuring expulsion of the parachute at substantially the upper limit of travel of the housing.

3. The combination of claim 2 wherein said anchor means includes a resilient member interconnecting the housing and the shroud lines for absorbing shock caused by expulsion of and opening of the parachute.

4. The combination of claim 2 wherein said housing is provided with an elongated guide member on the outer surface thereof for guiding the initial movement of the housing on a launching ramp.

5. The combination of claim 2 wherein said housing is provided with a liner on the inner surface thereof for providing a smooth surface for facilitating the expulsion of the parachute and protecting the housing from damage by the explosive mixture when it is ignited.

References Cited in the file of this patent

UNITED STATES PATENTS

	51,176	Hadfield	Nov. 28, 1865
	757,825	Maul	Apr. 19, 1904
	1,299,217	Pain	Apr. 1, 1919
	1,305,186	Bergman	May 27, 1919
	1,309,982	Darling	July 15, 1919
	1,754,986	Driggs et al.	Apr. 15, 1930
	2,344,957	Anzalone	Mar. 28, 1944