

IDS120j WITHOUT RESISTIVE MAGNETS: NEW Hg MODULE

mars1510: OFF VS. ON LAQGSM MODE SIMULATIONS

Nicholas Souchlas, (PBL) (11/8/2013)

IDS120j GEOMETRY, NO RESISTIVE MAGNETS: WITH 20 cm GAPS BETWEEN CRYOSTATS

MODIFIED Hg MODULE SIMULATES VAN GRAVE'S DESIGN.

DEPOSITED POWER DISTRIBUTION IN IDS120j TARGET STATION AND AZIMUTHAL

DEPOSITED POWER DENSITY DISTRIBUTION IN SC#1+SC#2 WITH LAQSM OFF / ON.

LAQSM MODE ==> IQSM=1 IN MARS.INP ICEM CARD FOR LIMITED EXCLUSIVE MODELING.

→ **SIMULATIONS CODE: mars15 (2010) [USING MCNPDATA x-SECTION LIBRARIES FOR NEUTRON INTERACTIONS WITH KE < 14 MeV]**

→ **NEUTRON ENERGY CUTOFF: 10^{-12} GeV**

→ **SHIELDING: 60% W + 40% He [WITH STST VESSELS]**

→ **$B_z (r = 0, z) : 15 \text{ T } [z = -37.5 \text{ cm }] \text{ ----> } 1.5 \text{ T } [z = 1470.0 \text{ cm }]$**

→ **Hg JET RADIUS / ANGLE: 0.4 cm / 0.09667 deg.**

→ **PROTON BEAM POWER: 4 MW**

→ **PROTON ENERGY: $E = 8 \text{ GeV}$**

→ **PROTON BEAM PROFILE : GAUSSIAN, $\sigma_x = \sigma_y = 0.12 \text{ cm}$ [P12 OBTAINED USING DING'S STUDY II OPTIMIZED DATA]**

→ **EVENTS IN SIMULATIONS : $N_p = 5,000,000$ [AVERAGE FROM 4 x 5E4 EVENTS]**

IDS120j: yz CROSS SECTIONS WITH DETAILS OF Hg POOL MODULE FROM VAN GRAVE'S PRESENTATION (8 / 9 / 2012).

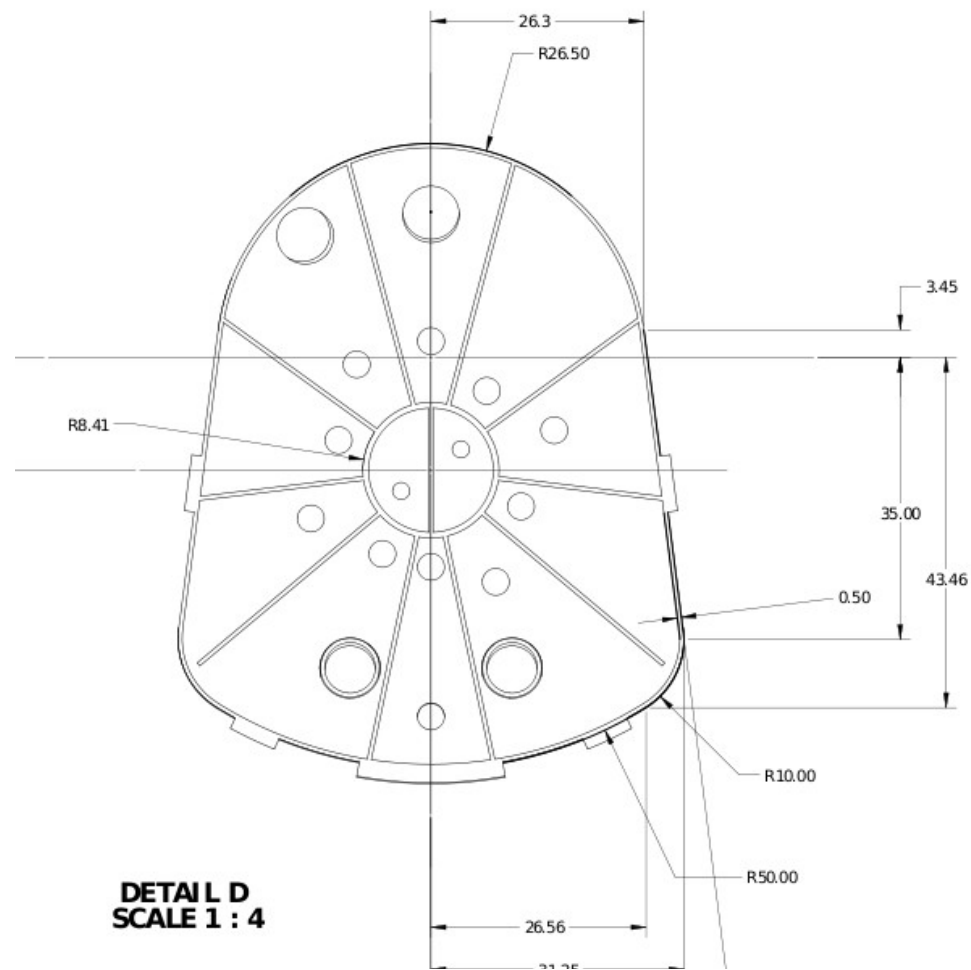
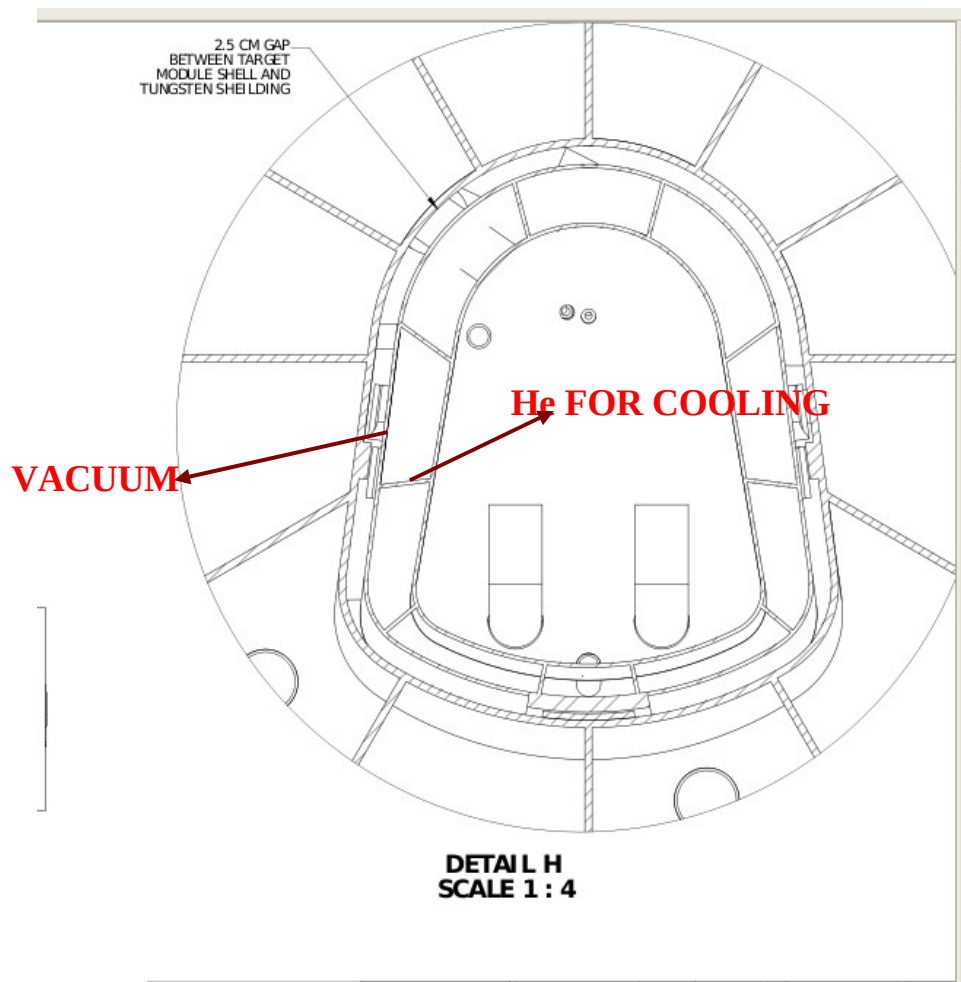

THE DESIGN REQUIRES A 2.5 cm ! GAP BETWEEN SH#1 INNER VESSEL AND Hg POOL MODULE OUTER VESSEL. AN EVEN LARGER SPACE APPEARS TO BE BETWEEN INNER AND OUTER VESSEL OF THE Hg POOL MODULE FOR THE FLOW OF He GAS FOR COOLING THE POOL. THE RADIUS OF THE UPPER HALF SEMICIRCULAR SECTION OF INNER Hg POOL VESSEL WILL BE 26.5 cm, MUCH LARGER THAN THE BEAM PIPE APERTURE AT THE END OF CRYO#1 (~ 17.7 cm).

IDS120j: yx CROSS SECTION WITH DETAILS OF Hg POOL MODULE FROM VAN'S PLOTS (LEFT 0) AND ADAPTED DESIGN FOR MARS SIMULATIONS (RIGHT) [AT z = 100 m].

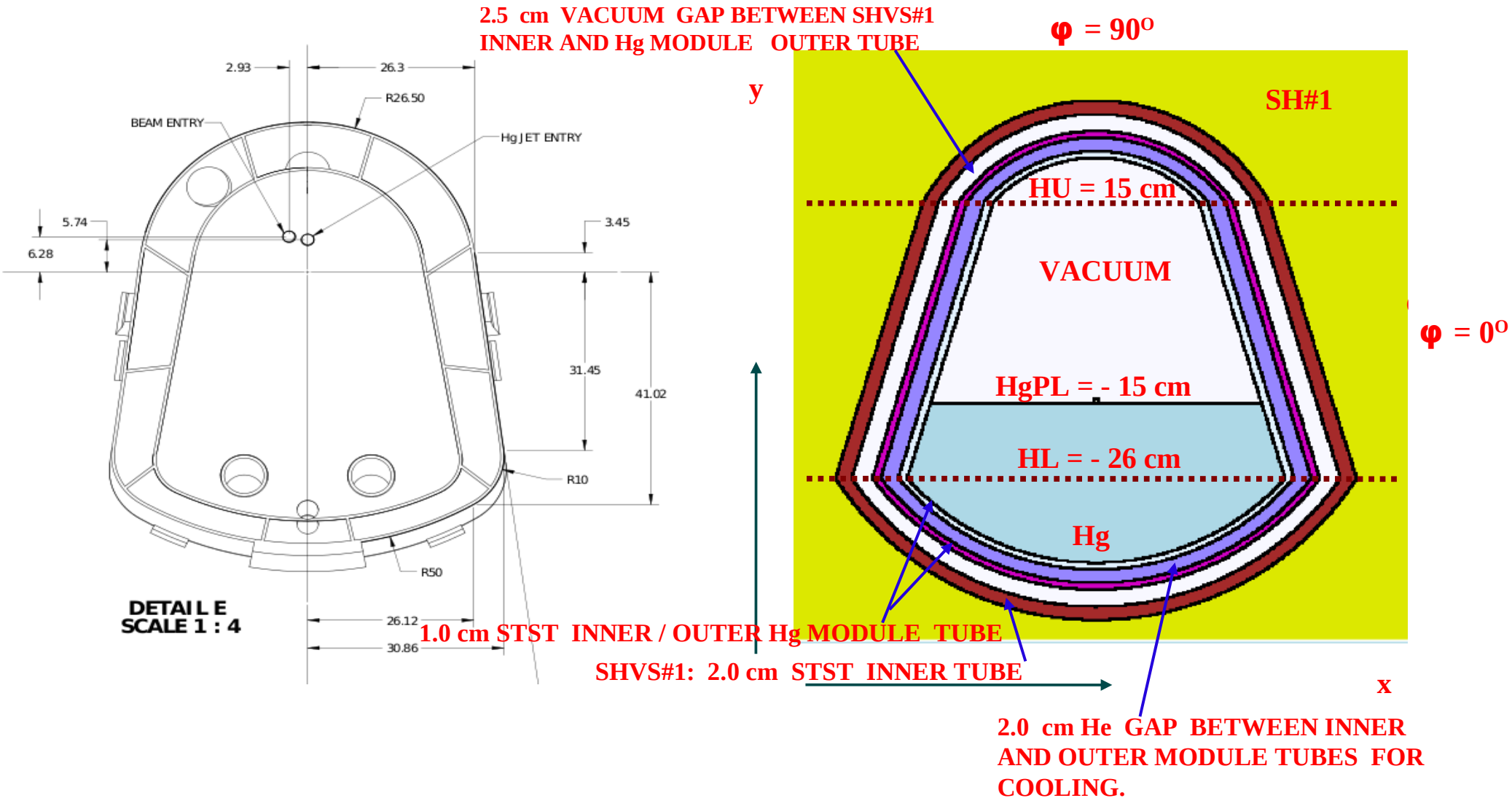

EVERYTHING HAS BEEN PARAMETRIZED FOR FUTURE CONVINIENCE. THE HEIGHTS OF THE END POINTS OF THE STRAIGHT SECTIONS ARE HL = - 26 cm AND HU = 15 cm. THE FREE Hg POOL SURFACE IS AT y = - 15 cm. THE RADIUS OF THE LOWER HALF OF THE INNER VESSEL OF THE Hg MODULE IS NOW SMALLER THAN BEFORE : FROM ~ 45 cm ----> ~ 39 cm. THE REST OF THE SPACE BETWEEN SHVS#1 INNER AND OUTER TUBE (AT R ~ 115 cm) IS FILLED WITH SHIELDING.

IDS120j: yz [LEFT] AND yx AT z = 10 cm [RIGHT] CROSS SECTION WITH DETAILS OF THE NEW Hg MODULE AND THE LOWER HALF OF THE UPSTREAM REGION.

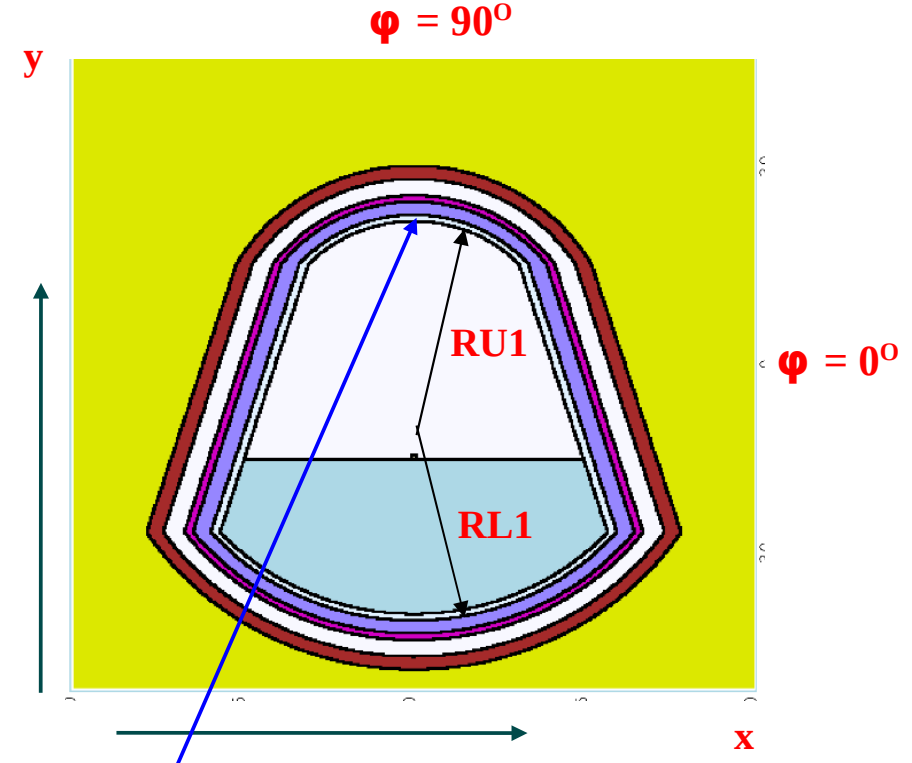
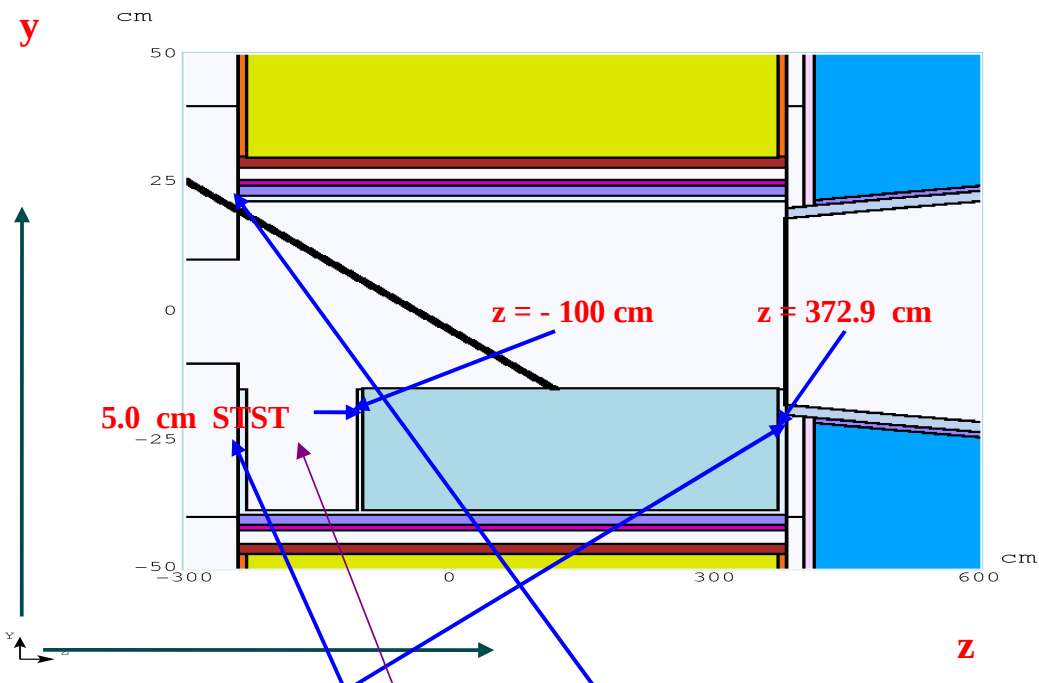

10 cm THICK STST FOR THE UPSTREAM AND DOWNSTREAM FLANGE OF Hg MODULE

THE RADIUS OF THE TOP SEMICIRCULAR SECTION OF THE Hg INNER TUBE IS SUCH THAT WILL NOT INTERFERE WITH THE Hg JET AND THE BEAM PROTONS AT THE BEGINNING OF CRYO#1 (z ~ - 240 cm) [RU1 = 28.0 cm AND RL1 = 45.0 cm]

ACCORDING TO VAN'S DESIGN THE VOLUME FROM THE BEGINNING OF CRYO#1 (z ~ - 240 cm) TO THE BEGINNING OF THE Hg POOL (z ~ - 100 cm) AND FROM y ~ -15 cm TO THE BOTTOM OF THE Hg MODULE INNER VESSEL (R ~ 39 cm) WILL BE EMPTY TO ACCOMODATE THE PIPES AND OTHER COMPONENTS OF THE Hg POOL MODULE.

SOME IMPROVEMENT IN SHIELDING IS ACHIEVED BY UNIFYING SH#1 AND SH#4. THERE WILL BE SIGNIFICANT INCREASE IN THE SHIELDING MASS (> 200 tons) TO BE CONTAINED IN THE NEW VESSEL (SHVS#1) ==> GREATER ASSYMETRY IN THE WEIGHT DISTRIBUTION. He COOLING OF SUCH A LARGE VOLUME (> 22 m³) OF SHIELDING CAN BE CHALENGING.

IDS120j: yz (LEFT) AND yx CROSS SECTION WITH DETAILS OF THE SC#1+2 SEGMENTATION.

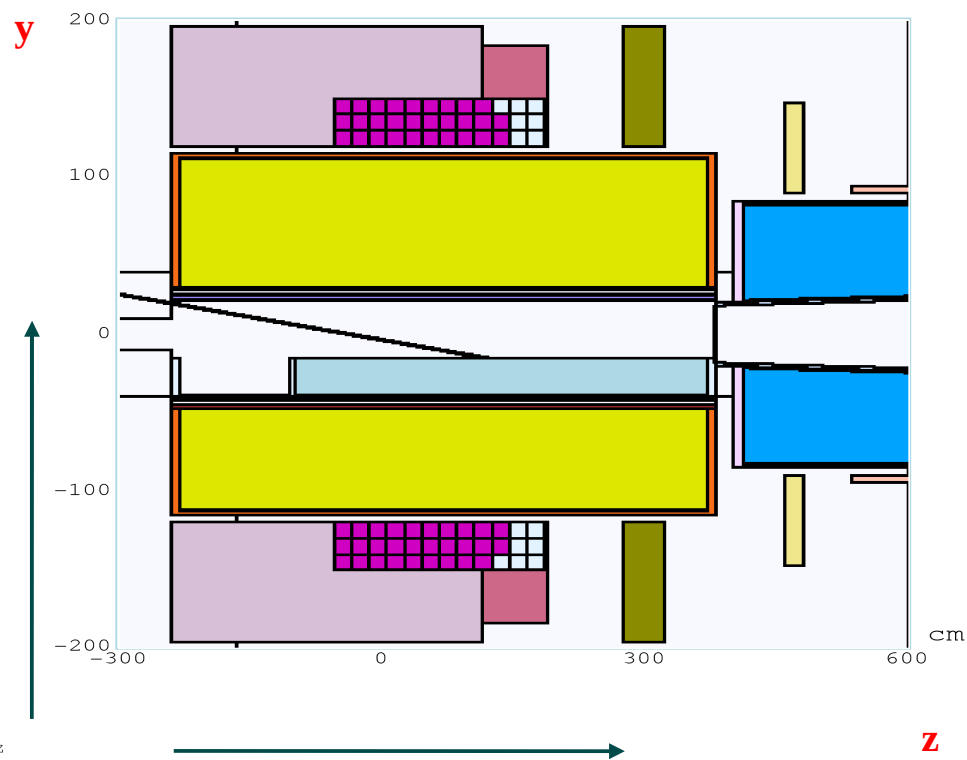

Aspect Ratio: Y:Z = 1:2.25

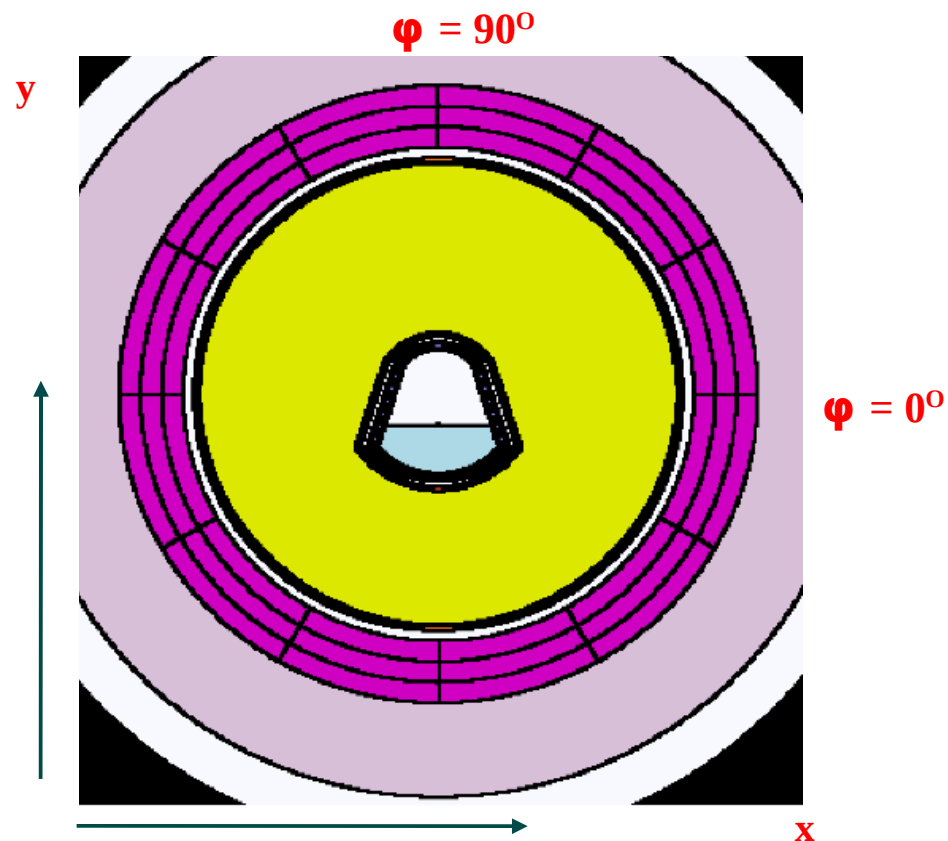

--- SEGMENTATION DATA ---

$120.0 < r < 150.0 \text{ cm}$	$dr = 10.0 \text{ cm}$	$N_r = 3 \text{ bins}$
$- 55.0 < z < 185.0 \text{ cm}$	$dz = 20.0 \text{ cm}$	$N_z = 12 \text{ bins}$
$0.0 < \phi < 360.0 \text{ deg.}$	$d\phi = 30 \text{ deg.}$	$N_\phi = 12 \text{ bins}$
$N_{\text{tot}} = 432 \text{ "pieces"}$		

ONLY THE AREA WITH HIGHEST AVERAGE AZIMUTHAL DPD (DETERMINED FROM MARS PLOTS) WAS STUDIED.

$(dr, dz, dphi) = (10$ cm, 20 cm, 30 deg) $\rightarrow (3, 12, 12)$ #BINS [AVERAGE FROM 4 x 5E05 RUN]

$(dr, dz, dphi) = (10$ cm, 20 cm, 30 deg) $\rightarrow (3, 12, 12)$ #BINS [AVERAGE FROM 4 x 5E05 RUN]

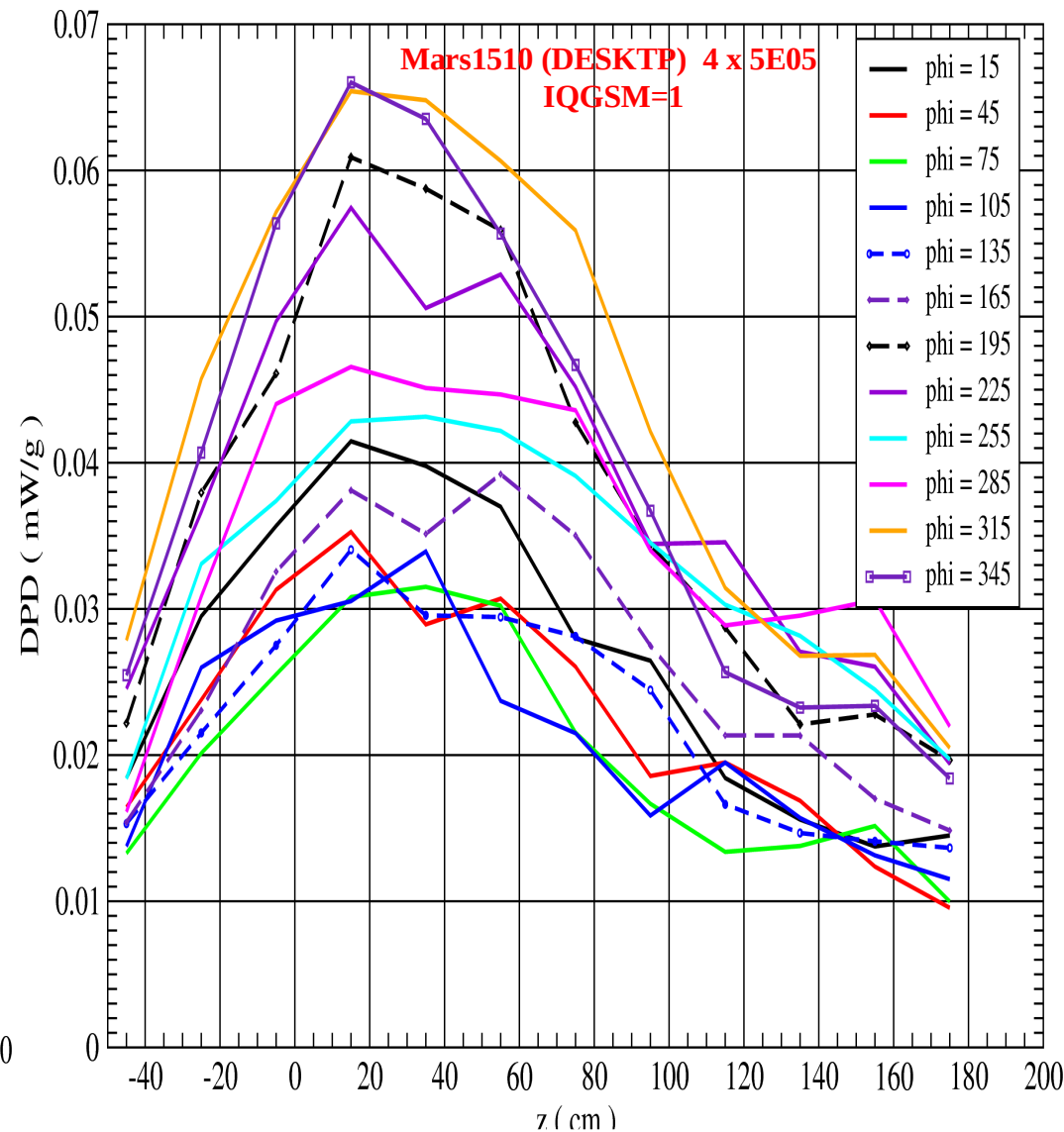
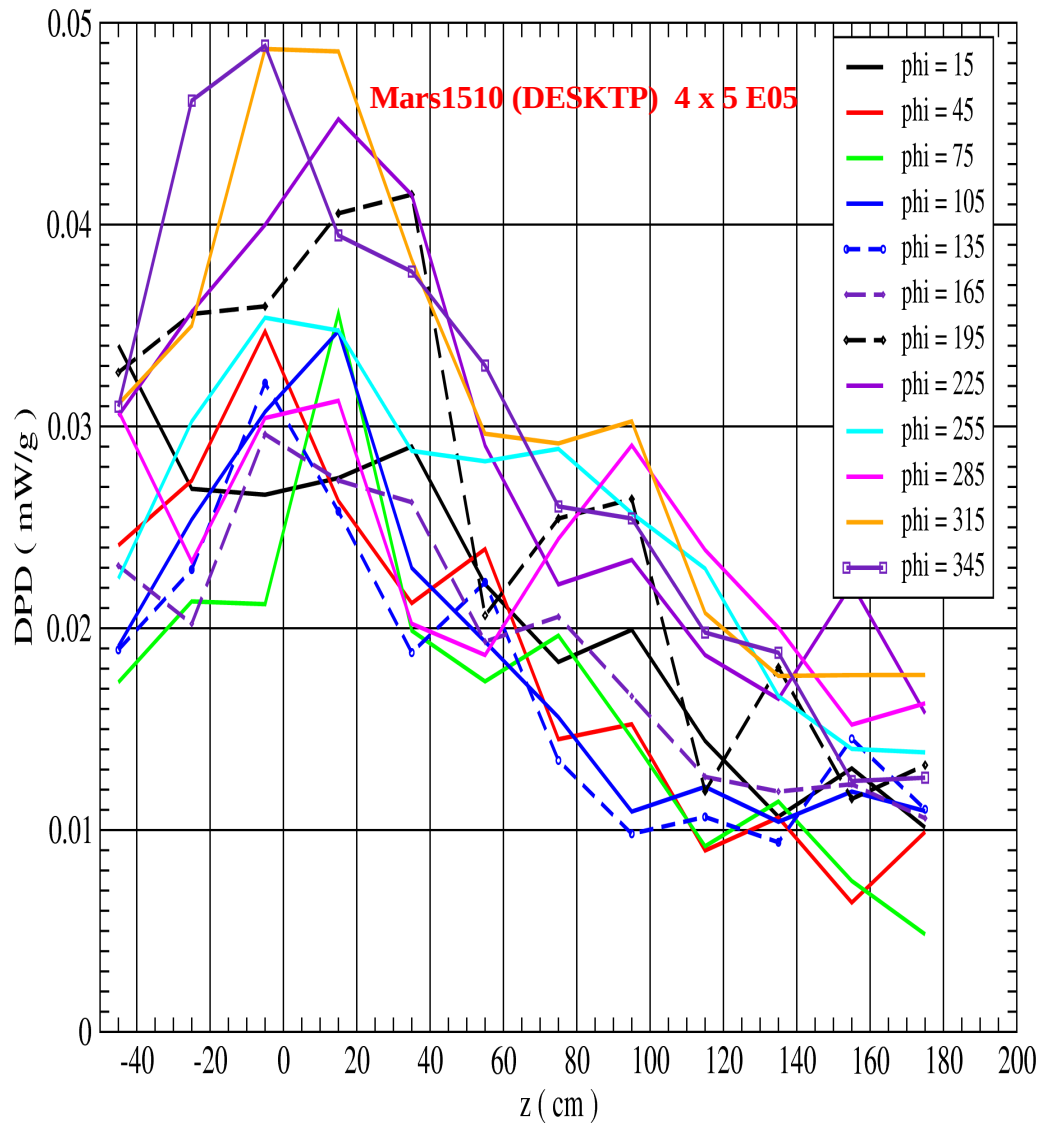

PEAK TDPD: LAQGSM OFF ~ 0.049 mW/g IN SC#1

LAQGSM ON (IQGSM=1) ~ 0.066 mW/g IN SC#1.

WITH LAQGSM MODE OFF MOST OF THE DP APPEARS TO BE BETWEEN $\sim -40 < z < 40$ cm AND IN THE LOWER HALF OF SC#1+2, TOWARDS THE +x DIRECTION. FOR IQGSM=1 MOST OF THE DEPOSITED POWER APPEARS TO BE FURTHER DOWNSTREAM APROXIMATELY BETWEEN $-20 < z < 80$ cm, LOWER HALF OF COILS TOWARDS +x DIRECTION AS BEFORE. THE PEAK TDPD IS A LITTLE HIGHER WITH IGGSM=1 AND MOST IMPORTANT IS SHIFTED FROM $z = -5$ cm TO $z = 15$ cm. IN GENERAL ALMOST IN EVERY DIRECTION WE HAVE HIGER TDPD VALUES AND, MOST IMPRESSIVE OF ALL, WE HAVE A MUCH SMOOTHER AXIAL VARIATION OF TDPD FOR ALMOST ALL 12 ANGLES

(dr, dz, dphi) = (10 cm, 20 cm, 30 deg)--> (3, 12, 12) #BINS [AVERAGE FROM 4 x 5E05 RUN]

(dr, dz, dphi) = (10 cm, 20 cm, 30 deg)--> (3, 12, 12) #BINS [AVERAGE FROM 4 x 5E05 RUN]

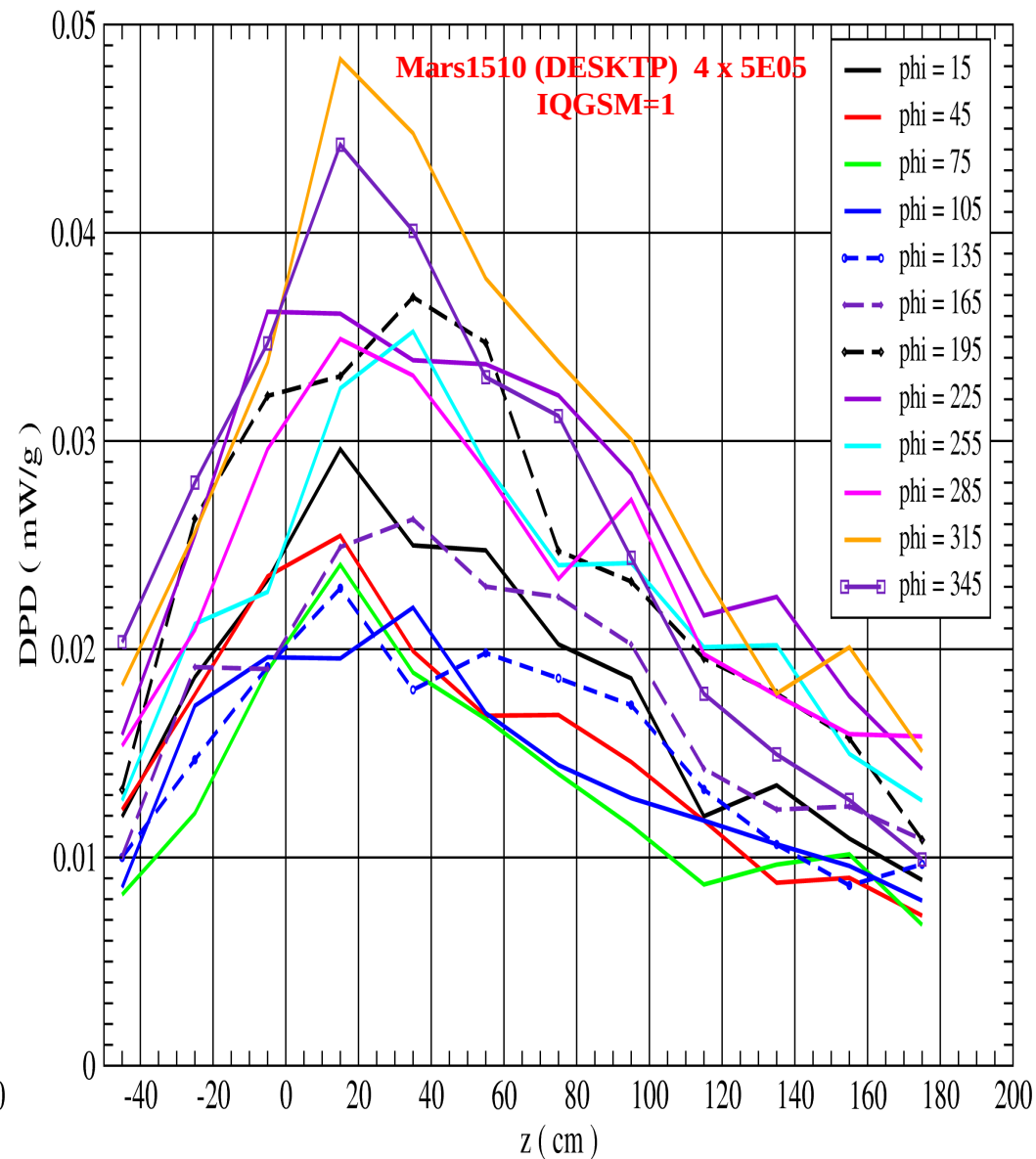
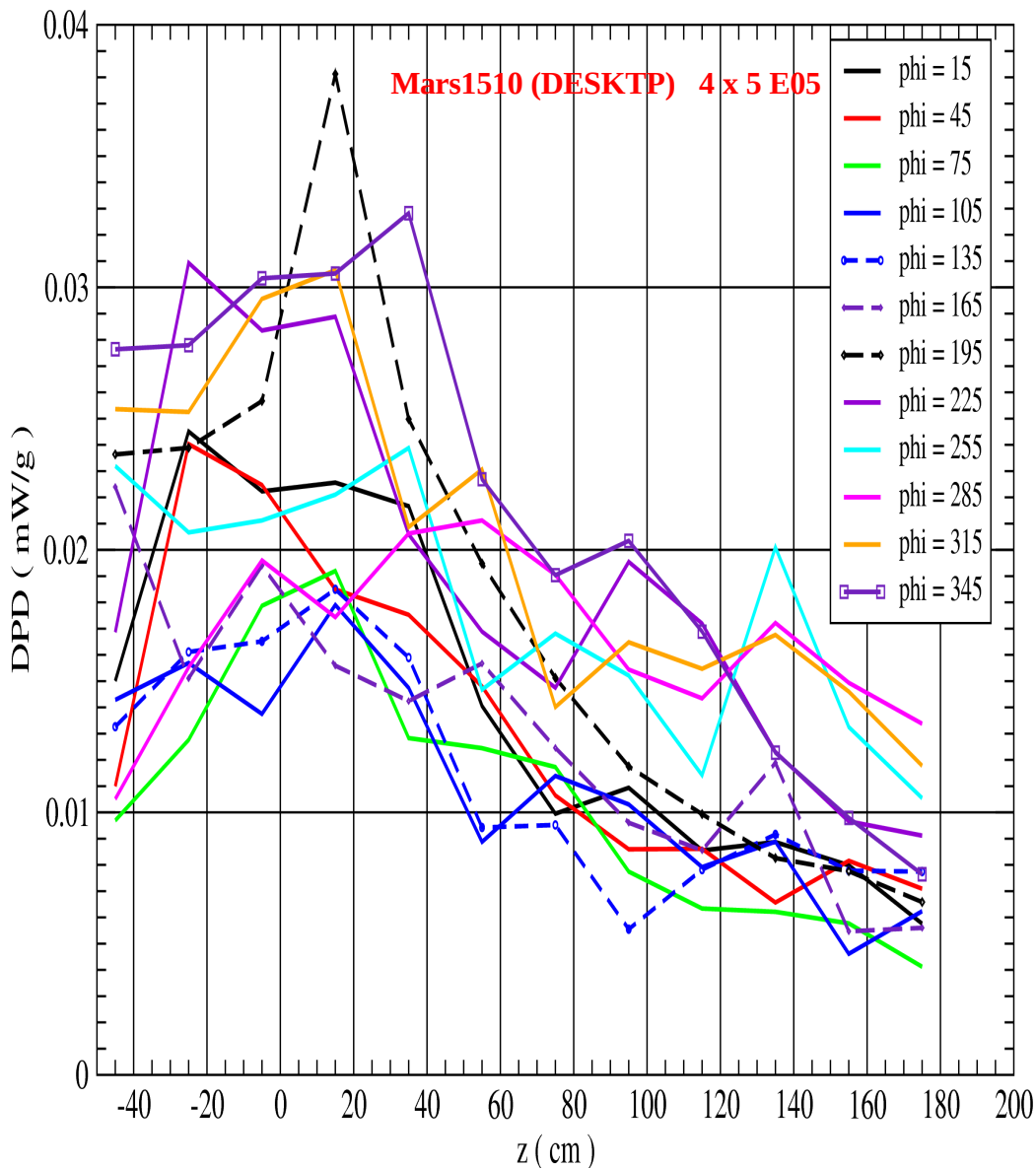

PEAK TDPD: (IQGSM = 0) ~ 0.038 mW / g

(IQGSM = 1) ~ 0.05 mW / g .

SAME COMMENTS FROM r = 125 cm RADIUS APPLY FOR R = 135 cm RADIUS, MORE DP APPEARS TO BE FURTHER DOWNSTREAM, SOMEWHAT HIGHER OVERALL TDPD VALUES AND SIGNIFICANT DECREASE IN FLUCTUATIONS FOR ALL DIRECTIONS.

$(dr, dz, dphi) = (10$ cm, 20 cm, 30 deg) $\rightarrow (3, 12, 12)$ #BINS [AVERAGE FROM 4 x 5E05 RUN]

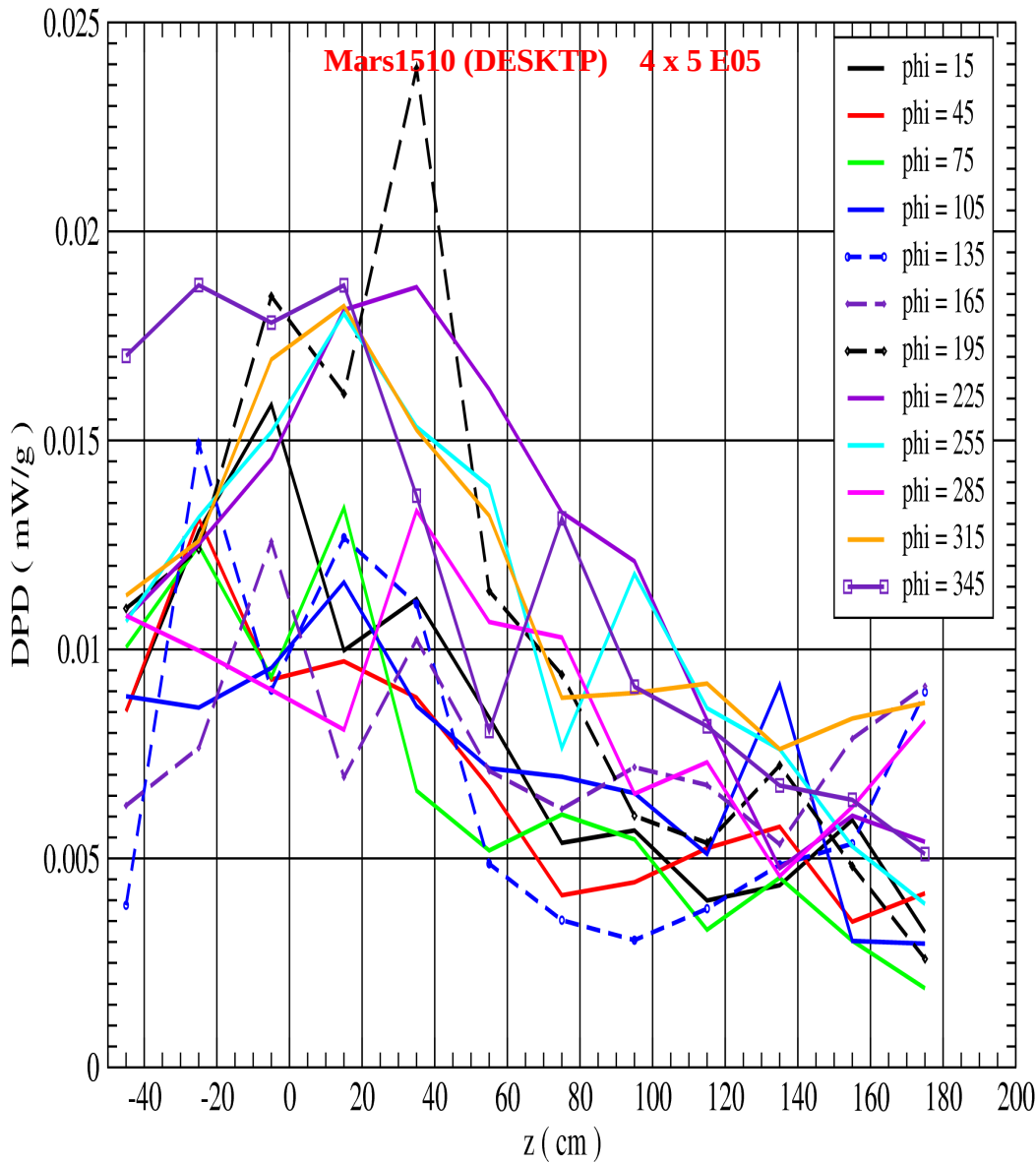

$(dr, dz, dphi) = (10$ cm, 20 cm, 30 deg) $\rightarrow (3, 12, 12)$ #BINS [AVERAGE FROM 4 x 5E05 RUN]

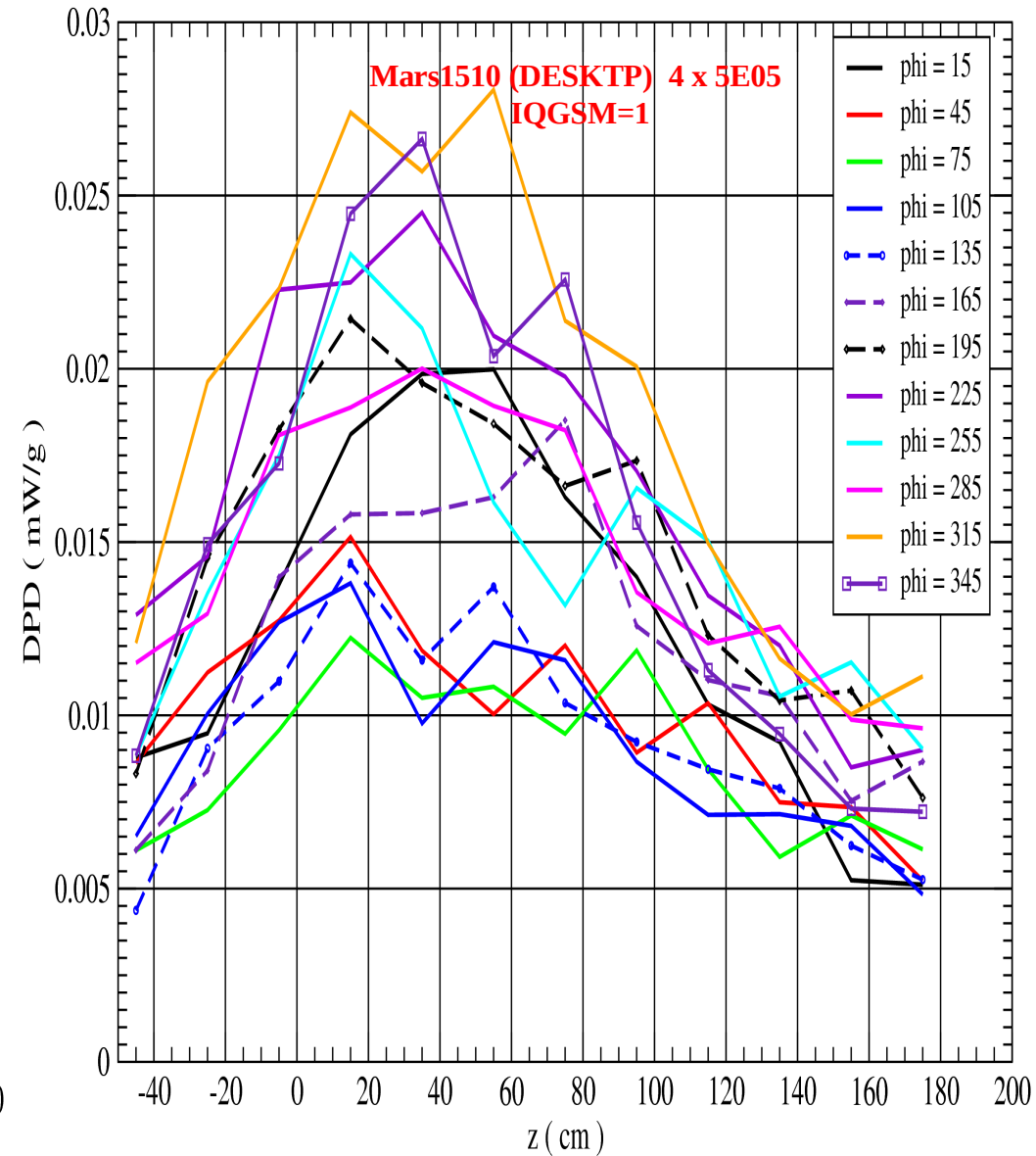

PEAK TDPD: (IQGSM = 0) ~ 0.024 mW / g

(IQGSM=1) ~ 0.028 mW / g .

SAME COMMENTS AS BEFORE APPLY FOR THE TDP DISTRIBUTION AND THE TDPD, THERE IS SOME IMPROVEMENT IN STATISTICAL FLUCTUATIONS FOR CERTAIN DIRECTIONS BUT OVERALL NOT AS MUCH IMPROVEMENT AS FOR THE OTHER TWO RADII.

mars1510 [IQGSM = 0]: 4 x 5E5 ~ 2 - 3 DAYS VS. mars1510 [IQGSM = 1]: 4 x 5E5 ~ 4 - 5 DAYS

A) THE PEAK DPD IN SC#1+2:

mars1510 [IQGSM=0]: ~ 0.049 mW / g AT (r, z, phi) = (125 cm, -5 cm, 345 deg) IN SC#1 [4 x 5E5 EVENTS]

mars1510 [IQGSM =1]: ~ 0.066 mW / g AT (r, z, phi) = (125 cm, 15 cm, 345 deg) IN SC#1 [4x 5E5 EVENTS]

***** DEPOSITED POWER IN DIFFERENT PARTS OF THE TARGET STATION IN kW *****

B) SC#1+2: [0.647 (+0.271)=0.918 VS. 0.924 UNSEGMENTED COILS] 0.879 (+ 0.318)= 1.197 VS. ???

WHERE NUMBERS IN (.)= DP IN UNSEGMENTED PART OF SC#1+2

SC#3: [0.066]	0.071	SC#4: [0.149]	0.137
SC#5: [0.017]	0.014	SC#6: [0.005]	0.003
SC#7: [0.008]	0.008	SC#8: [0.010]	0.011
SC#9: [0.004]	0.004	SC#10-12: [0.159]	0.186
TOTAL DP SC#1-12: [1.336]		1.631	

C) DP IN SHIELDING SH#1 : [573.30] 674.25

SH#2 : [93.70] 86.29

SH#3 : [10.12] 10.50

SH#4 : [4.77] 5.73

D) DP IN VESSELS SHVS#1 : [3.13] 2.87

SHVS#2 : [39.82] 42.18

SHVS#3 : [3.33] 3.81

SHVS#4 : [0.49] 0.58

E) DP IN Hg JET : [406.23] 353.99

DP IN Hg POOL : [1248.78] 1174.62

F) DP IN Be WINDOW : [10.17] 8.13

DP IN BP#2 : [106.09] 97.21

DP IN BP#3 : [19.23] 19.19

DP IN Hg POOL INNER TUBE : [273.53] 253.26

DP IN Hg POOL OUTER TUBE : [164.73] 167.30

DP IN SHVS#1 INNER TUBE : [163.53] 179.48

TOTAL DP : [3,122.37] 3,080.52

****** COMMENTS ON MARS WITH LAQSM MODE OFF / ON ******

- # OVERALL LITTLE HIGHER TDPD IN ALL DIRECTIONS, MOST TDP APPEARS TO BE FURTHER DOWNSTREAM FOR SC#1+2 SEGMENTATION.**
 - # SIGNIFICANT IMPROVEMENT IN STATISTICAL FLUCTUATIONS OF TDPD AXIAL VARIATION FOR ALL ANGLES FOR SC#1+2 SEGMENTATION.**
 - # INSIGNIFICANT DIFFERENCE IN SCs TDP.**
 - # WITH THE EXCEPTION OF A FEW VOLUMES, MAINLY SH#1 REGION, AND LESS Hg POOL / JET, THERE IS ONLY A SMALL CHANGE IN THE ESTIMATED DEPOSITED POWER IN DIFFERENT AREAS OF THE STATION.**
- ENERGY DEPOSITION STUDIES WORK SO FAR, IN GENERAL IS STILL VALID AND TRUSTWORTHY.**

IDS120j: yz CROSS SECTION WITH THE PROTON BEAM CENTROID P12 TRAJECTORY SHOWING (RIGHT) AND WITHOUT SHOWING (LEFT) THE Hg POOL AND Hg JET.

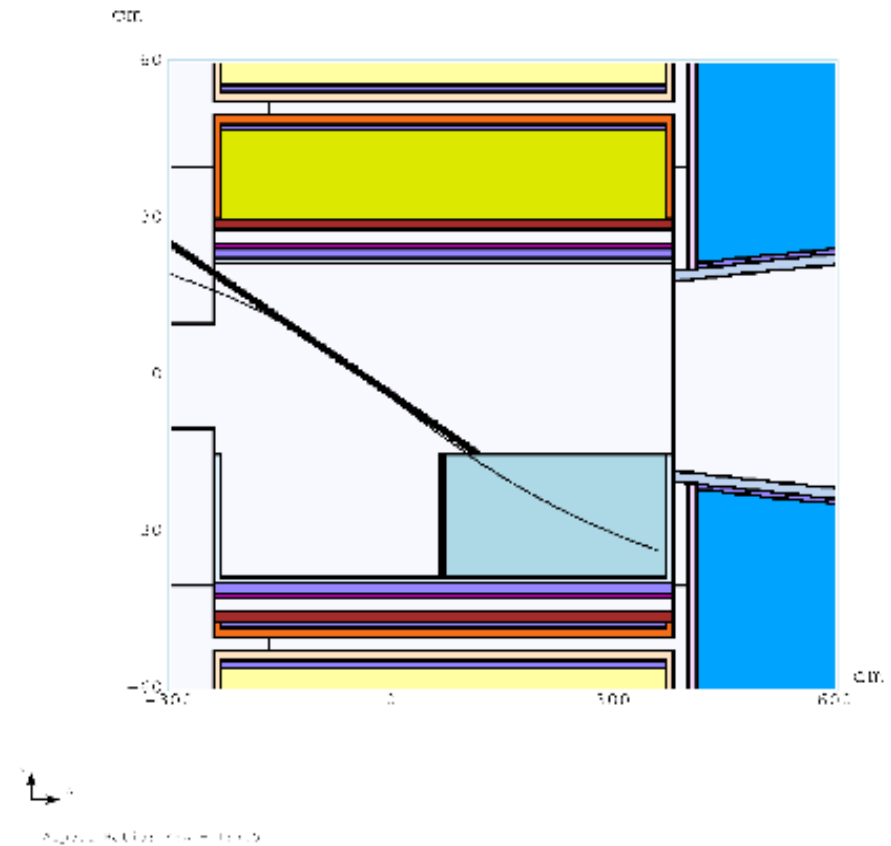
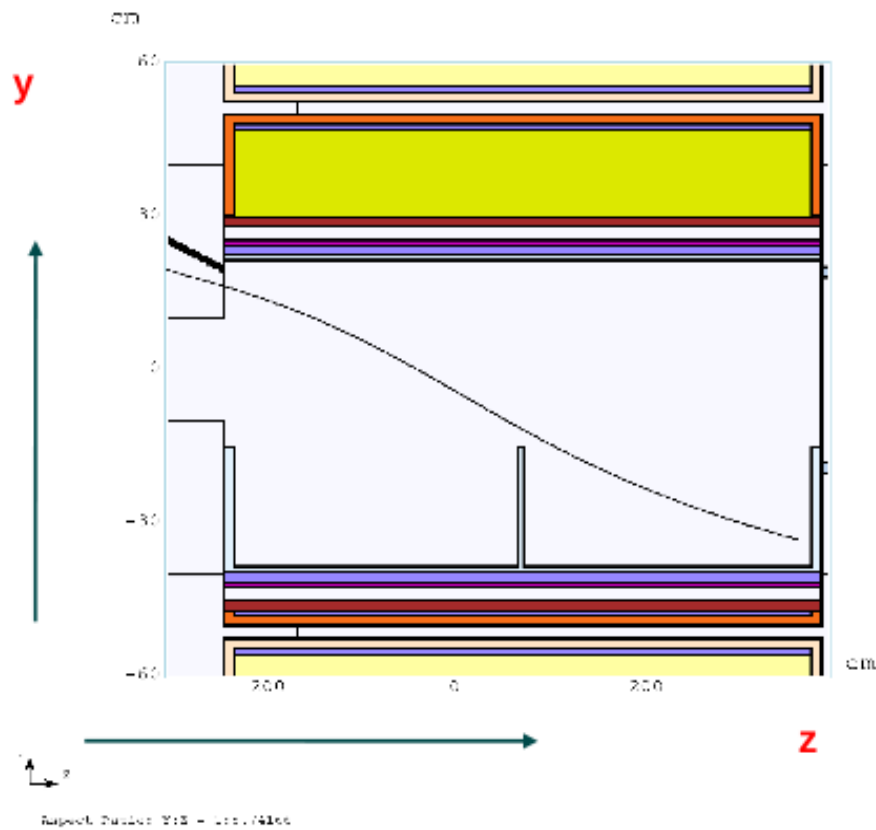

PROTONS ENTER THE Hg POOL AT $(x, y, z) \sim (-1.61, -15.00, 104.66)$ cm AND WILL BE STOPPED BY THE SIDE (SEMICIRCULAR) WALL AT $(x, y, z) \sim (-19.39, -33.26, 358.80)$ cm (~ 10 cm BEFORE THEY REACH THE RIGHT SIDE FLANGE OF Hg MODULE) COVERING A DISTANCE ~ 255.41 cm ~ 17 IL (1 IL ~ 15 cm).

IS IT POSSIBLE FOR POOL TO BE SORTER AND FILL THE REST OF THE UPSTREAM VOLUME WITH SHIELDING ?

NOTICE : R1, HU (HL ?) DIMENSIONS OF Hg MODUL ARE DETERMINED FROM THE SPACE NEEDED FOR THE PROTON BEAM TRAJECTORY. DIFFERENT INJECTION POINTS WILL PROBABLY REQUIRE DIFFERENT VALUES FOR THESE PARAMETERS.

IDS120j: yx (AT $z = 200$ cm) (LEFT) AND xz (RIGHT) CROSS SECTION WITH THE PROTON BEAM CENTROID P12 TRAJECTORY.

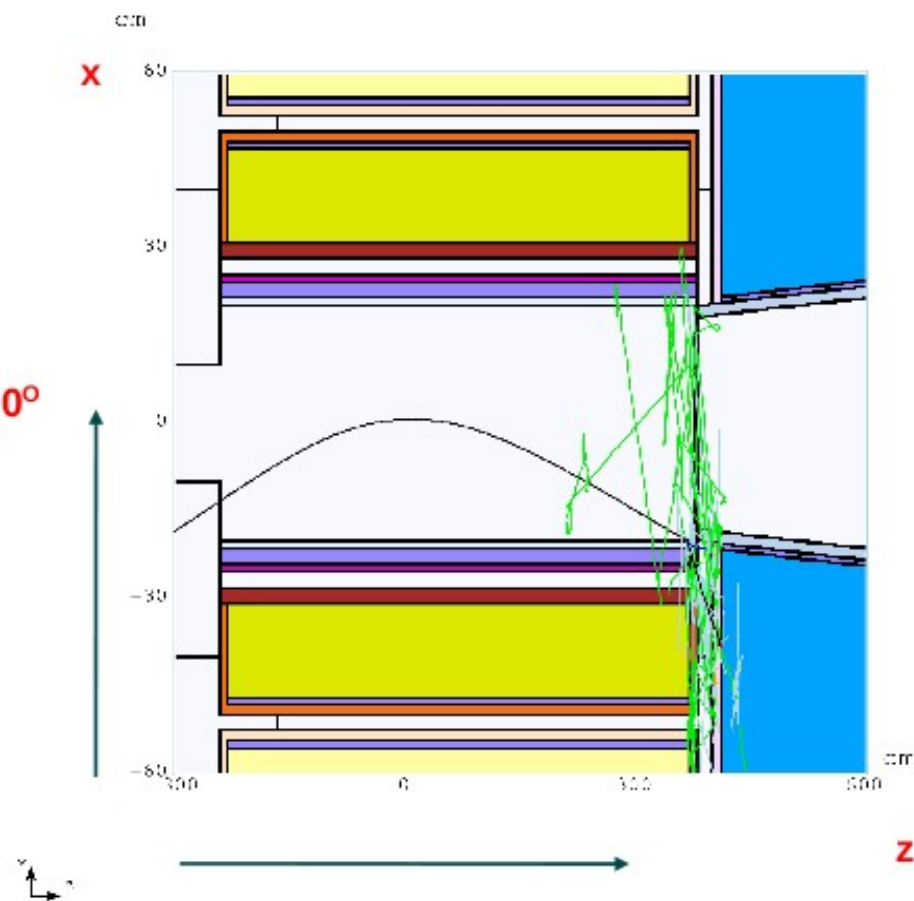
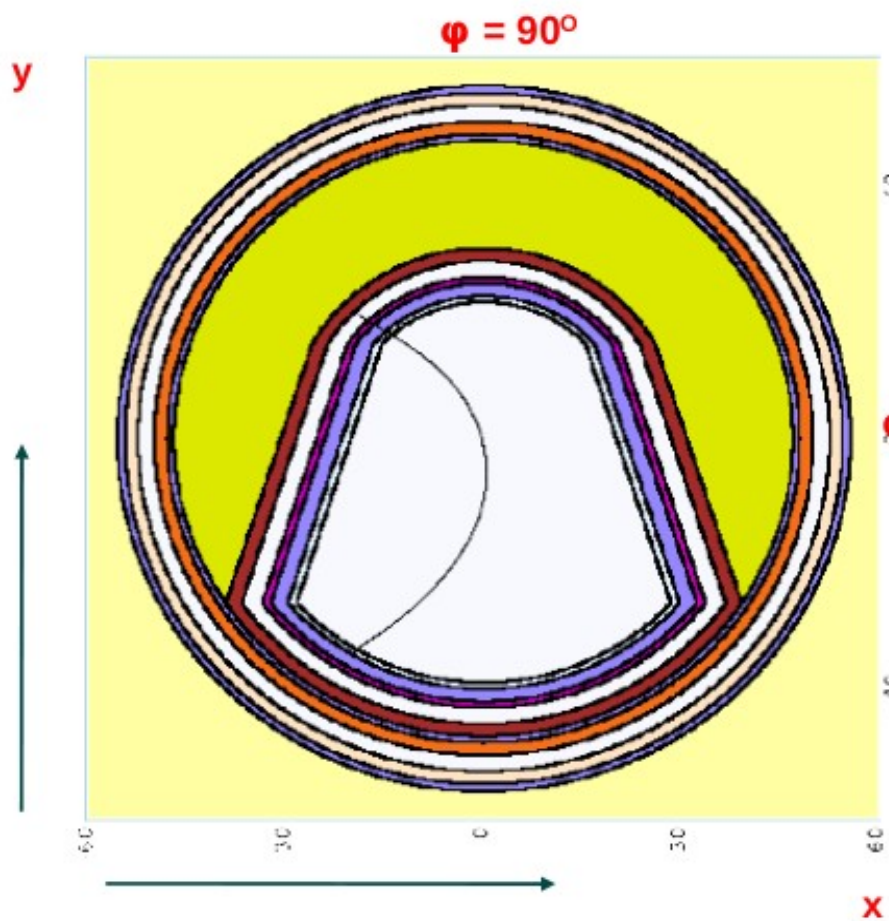

Aspen 11.0.0.0 (2011-01-14)