

Pipe Simulations

- update on the pipe with a partial weld

Yan Zhan

May 7th 2013

Mesh For The Pipe With A Partial Weld

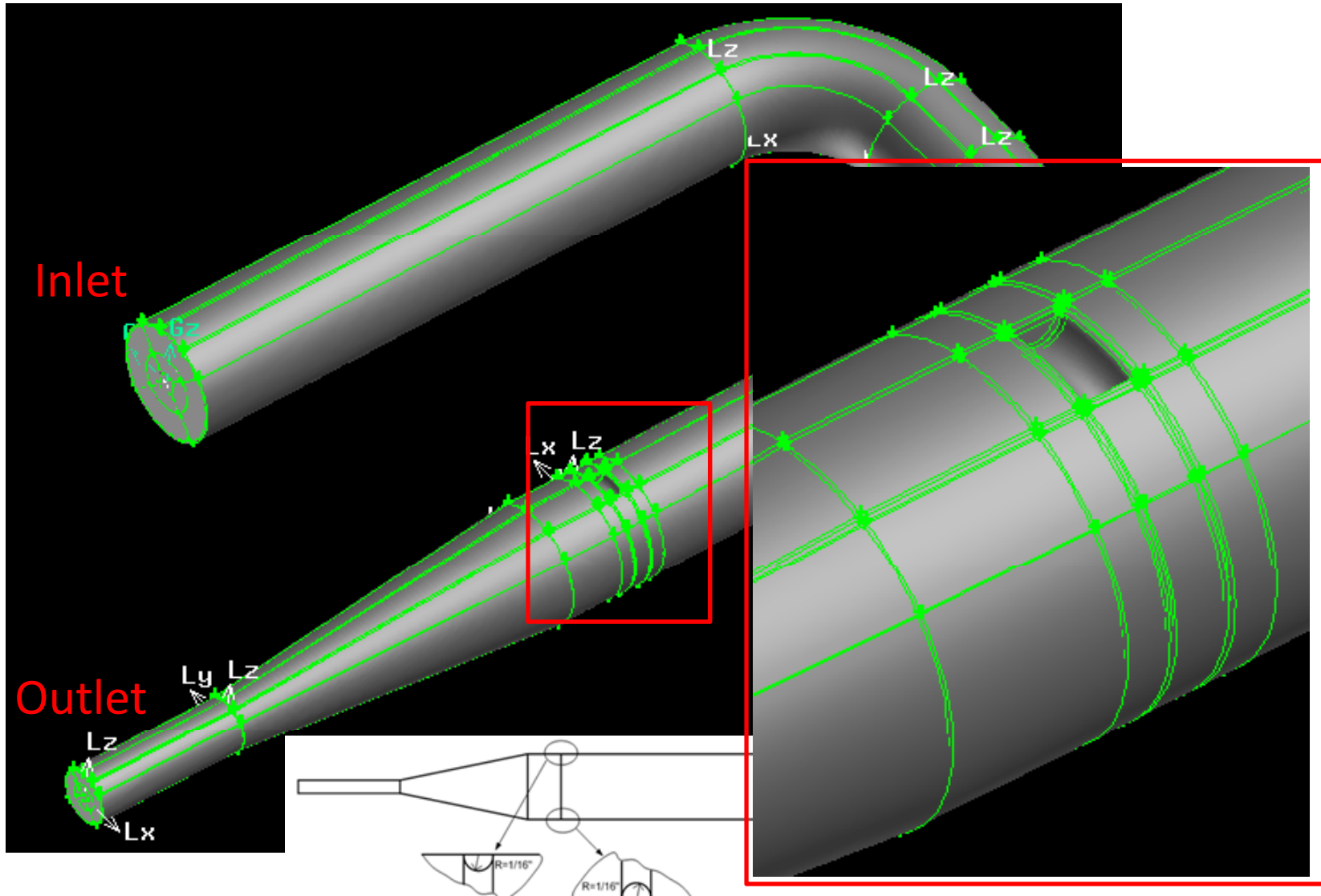

Turbulence Intensity At the Outlet

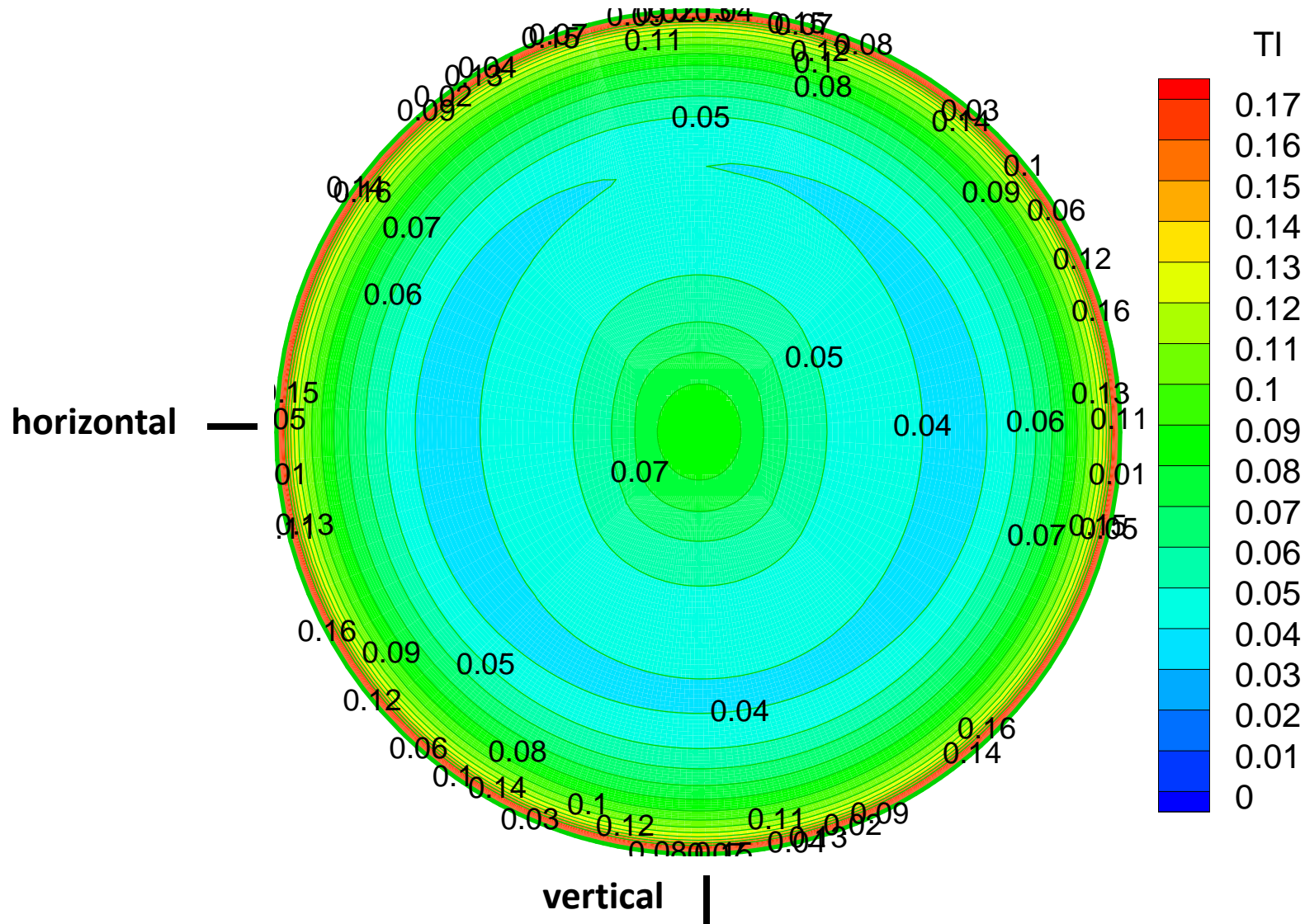

Contour of turbulence intensity at the outlet of pipe

Turbulence Intensity At the Outlet

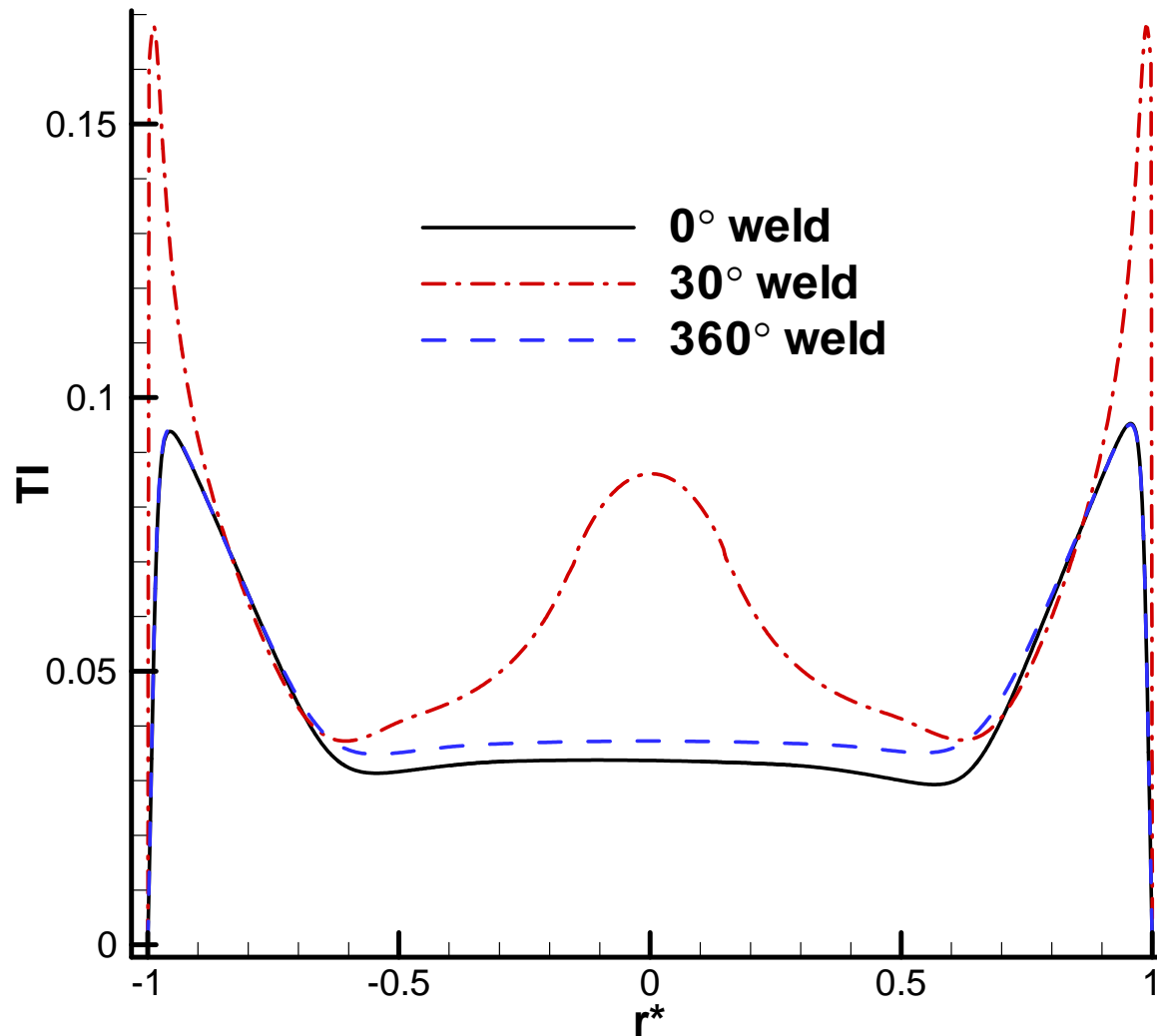

Horizontal line plot of turbulence intensity at the outlet of pipe

Turbulence Intensity At the Outlet

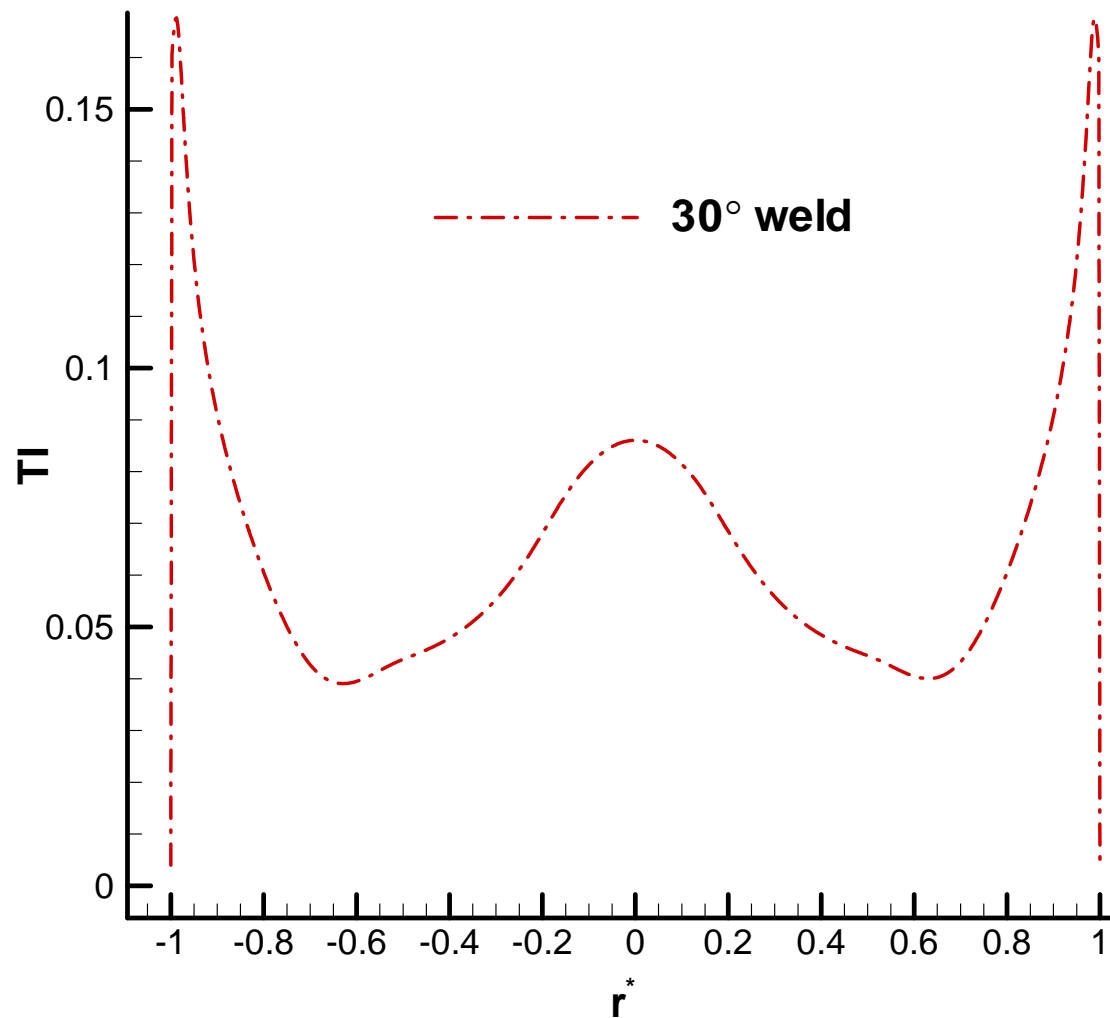

Vertical line plot of turbulence intensity at the outlet of pipe