

NOTES
1. MATERIAL CERTIFICATIONS REQUIRED

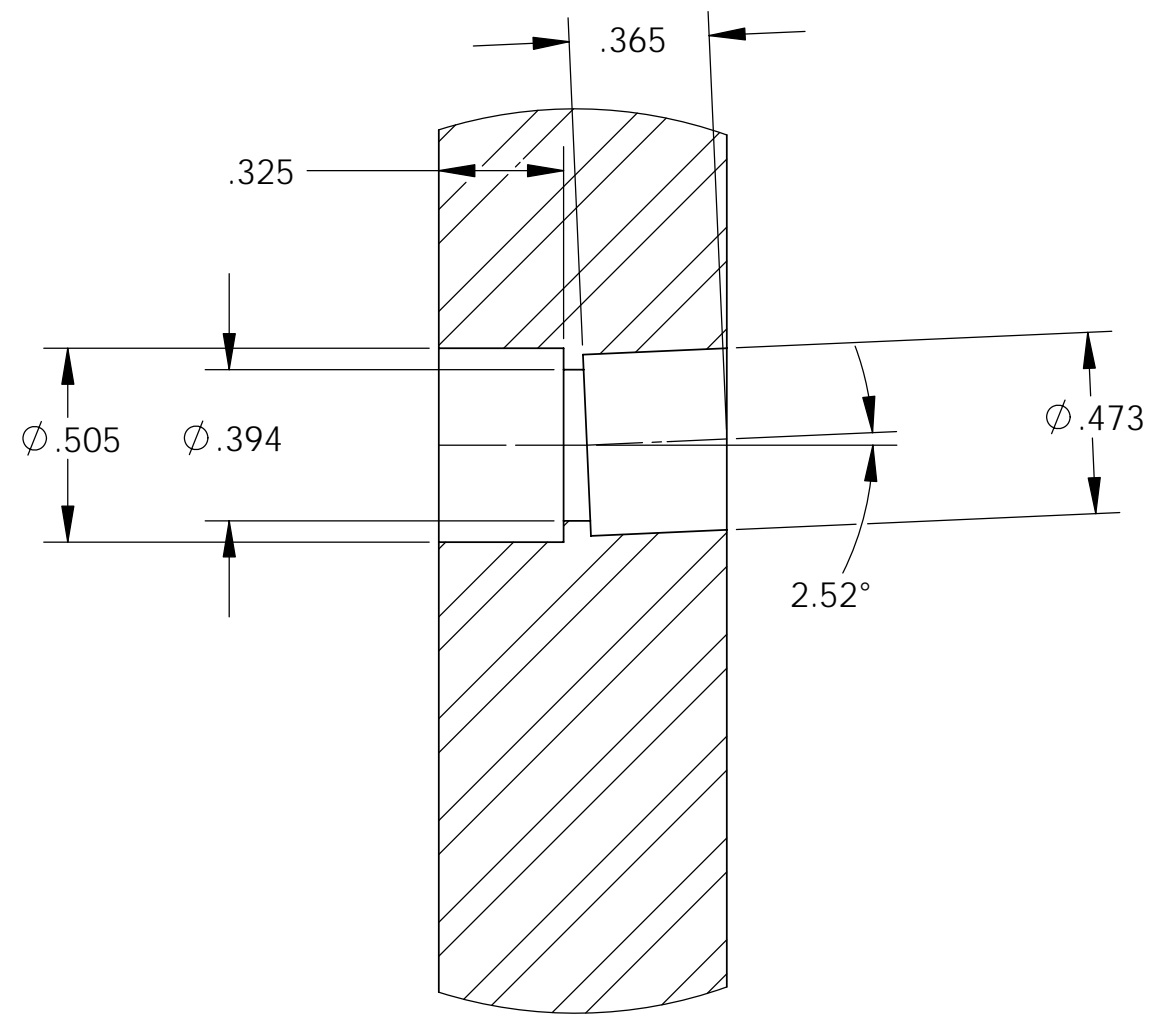

DETAIL B
SCALE 2 : 1

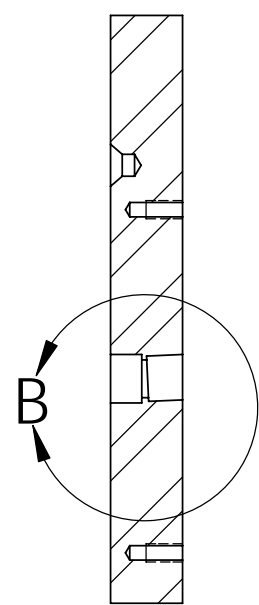
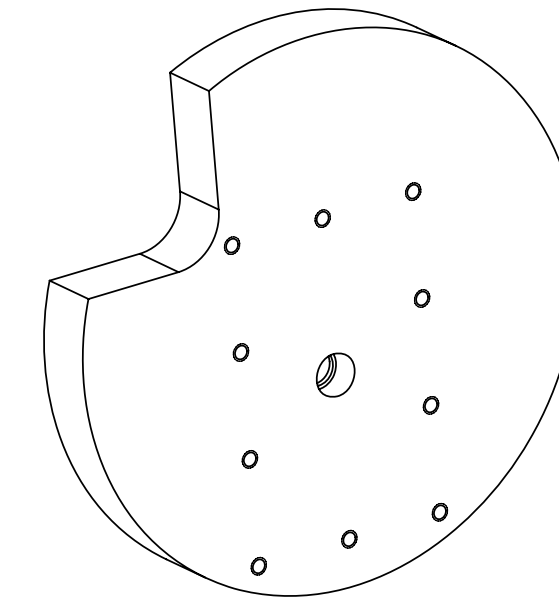
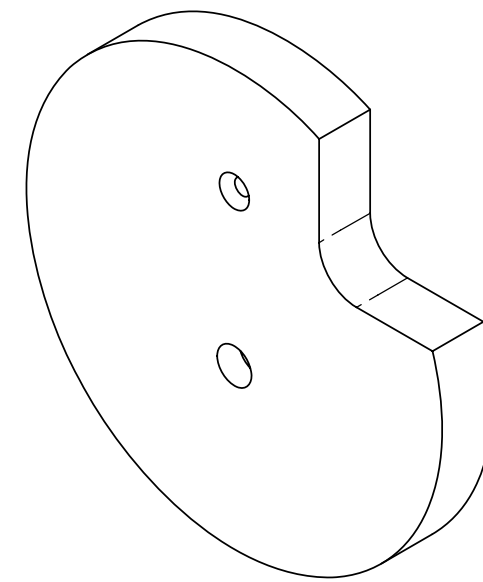

SECTION A-A

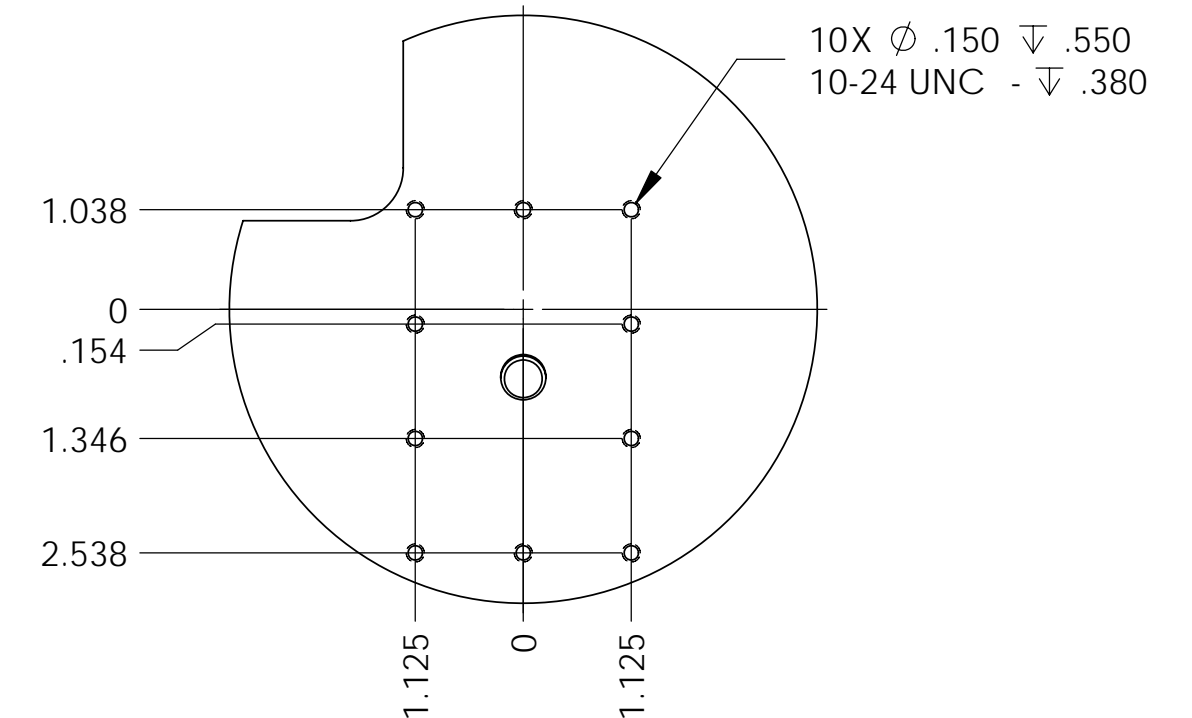
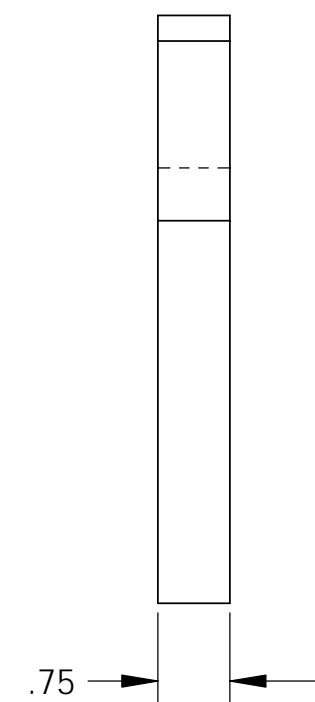
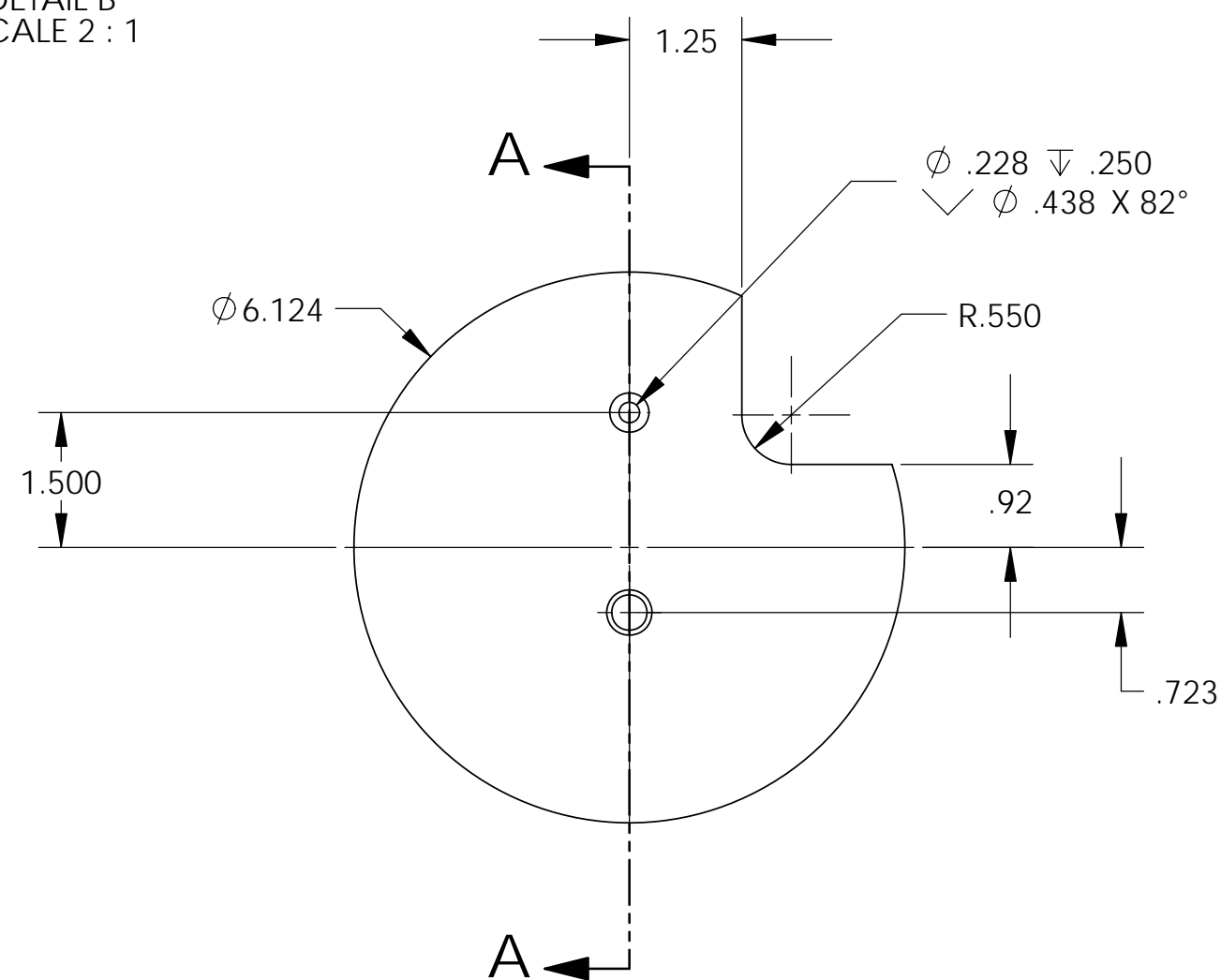

MATERIAL: SS - 316L, ASTM A240

<p>THIRD-ANGLE PROJECTION</p>	This drawing was prepared by ORNL solely for use in work performed under Department of Energy contract number DE-AC05-00OR22725 and applicable Work for Others Agreements and Cooperative Research and Development Agreements. This drawing is property of ORNL and must be returned upon request.			<p>OAK RIDGE NATIONAL LABORATORY operated for the U.S. Department of Energy under contract DE-AC05-00OR22725 Oak Ridge, TN</p>		
	UNLESS OTHERWISE NOTED 1. ALL DIMENSIONS ARE IN INCHES 2. INTERPRET DIMENSIONS AND TOLERANCES PER ASME Y14.5M 3. MACHINED FINISH 125 MICRO-INCHES RMS 4. CONCENTRICITY .010 TIR 5. MACHINED ANGLES ±1/2° 6. BREAK SHARP CORNERS AND REMOVE ALL BURRS 7. WHOLE NUMBERS AND FRACTIONS ±1/16 8. X DECIMALS ±.030 9. XX DECIMALS ±.010 10. XXX DECIMALS ±.005			<p>REMOTE SYSTEMS GROUP NUCLEAR SCIENCE & TECHNOLOGY DIVISION</p>		
DES	V GRAVES	01/26/2006	MERIT EXPERIMENT HG SUPPLY ASSEMBLY NOZZLE FLANGE			
DRW	T OQUIN	01/26/2006				
CHK	P SPAMPINATO	03/07/2006				
ENG	V GRAVES	01/26/2006				
QA			CAD FILE	PREV ASSY	SCALE	SHEET
			HG NOZZLE FLANGE HJT	203-HJT-0620A	1:2	1 of 1
DRAWING APPROVALS		DATE	SIZE	DWG NO.	REV	
			C	203-HJT-0622A	0	