

Design and Operational Features of a Mercury Target Facility

**Based on Experience at the
Spallation Neutron Source at
Oak Ridge National Laboratory**

**Mark Rennich
Van Graves**

**Neutrino Factory International
Design Study Kick-off Meeting**

Dec 15-17, 2008

CERN



Contributors

- **Tom McManamy, Chief Engineer, Neutron Facilities Development Division**
- **Mark Rennich, SNS Remote Handling**
- **Dave Lousteau, SNS Target Design**
- **Lorelei Jacobs, SNS Utility Systems**
- **Joe Devore, SNS Radiation Waste Management**
- **Chengeng Zeng, Student Researcher**
- **David Freeman, SNS Instrument Support Group Leader**

Outline

- **Scope**
- **Mercury as a target**
- **Activated mercury considerations (solid, liquid, gas)**
- **SNS mercury related facilities**
- **Summary**

Scope

- **Goal: to raise awareness of the design and operational requirements associated with handling and processing activated mercury**
- **Based on the experience gained at the Spallation Neutron Source (SNS)**

Mercury as a Target

- **Mercury has been shown to have important operational advantages as a high energy accelerator target:**
 - **High Mass Density**
 - **Life of Facility**
 - **Low Decay Heat Density**
 - **Good Heat Transfer Characteristics**
 - **High Operational Reliability**

SNS Target Statistics Compared with Neutrino Factory

	SNS	NF
Proton beam power on target	1.4 MW	1 MW, upgradeable to 4 MW
Proton beam kinetic energy on target	1.0 GeV	24 GeV
Pulse rate	60 Hz	50 Hz
Nominal beam profile	$\sigma_x = 100\text{mm}, \sigma_y = 70\text{mm}$	$\sigma_r = 1.5\text{mm}$
Protons/pulse on target	$1.5 \cdot 10^{14}$	$4.9 \cdot 10^{14}$ @ 4 MW
Hg volume	1400 liters	110 liters
Mercury temperature	90°C max	102°C @ 1 MW
Pump Discharge Pressure	2.5 bar	40 bar
Nominal flow rate	1440 liters/min	94 liters/min for 20m/s jet

SNS Mercury Target



Characteristics of Proton Beam Activated Mercury

- The following isotopes have been observed in SNS mercury wastes:
 - Mercury Isotope Hg-203
 - Mercury daughter and spallation product isotopes Hf-175, Hf-172, Lu-172, Lu-173, Au-194, Au-195, Tm-168, Re-183, Os-185, & Yb-169
- Isotopes “plate” the inside of the mercury process components.
- Measured radiation dose in piping dependent upon presence of mercury.
 - Dose rate increase of 2X-3X observed when Hg drained
- SNS experiencing approximately linear response of 0.14-0.18 Grays/hr/kW beam power.

SNS Radiation Measurements After Shutdown

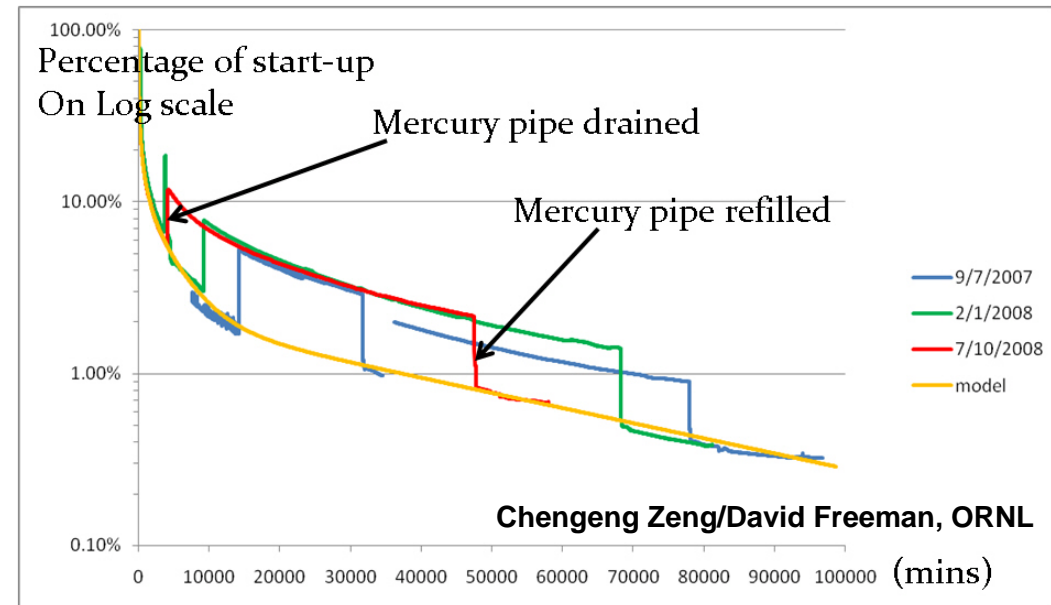

Mercury as a LIQUID

- **Liquid mercury easily disperses in drops which accumulate in low points and difficult-to-reach openings.**
- **Micro-drops form in small cracks and crevices. These have proven to be extremely difficult to clean.**
 - **ORNL uses sulfur-based solutions and ultrasonic cleaners with mixed results.**
- **Unless disturbed, the oxide layer on the outside of mercury drops substantially slows vaporization.**
 - **If the oxide layer is broken (e.g., vibration) a “plume” of mercury vapor will form.**
- **Liquid drops will form on surfaces which have been wiped clean.**
 - **This can cause problems when dealing with waste which has been declared liquid-free.**

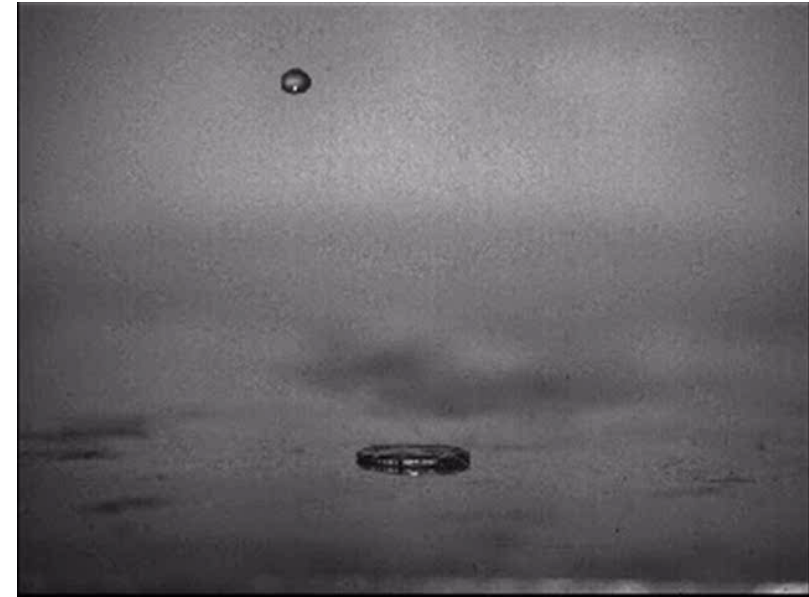

Movie comparing water & Hg drops

Observation of Hg contamination on a flask using a stereo microscope ($\times 40$) after wiping with Hg-absorbing wipes

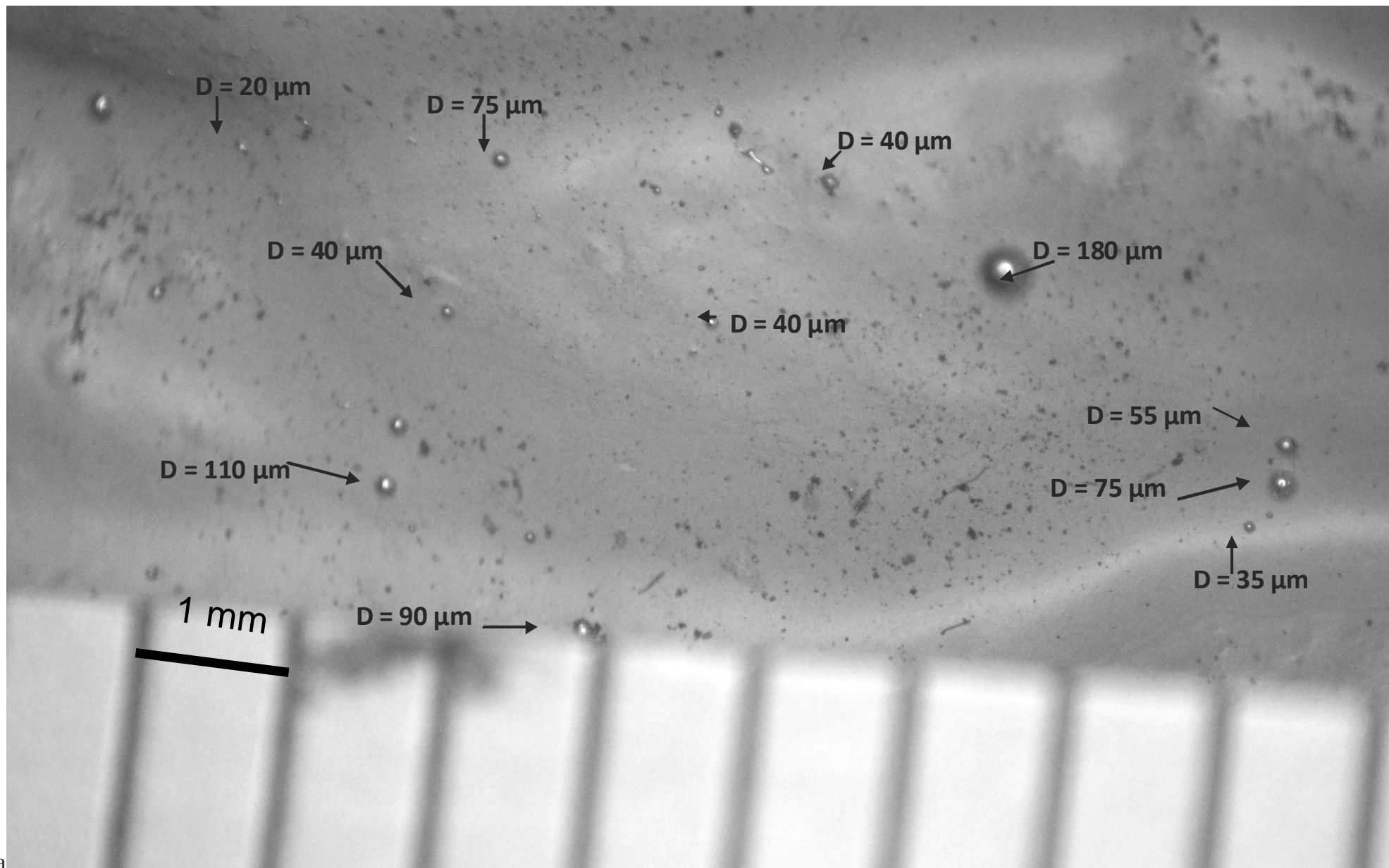

Mercury as a GAS

- **Mercury vapor is very hazardous due to its biological toxicity.**
 - Normal working limit for workers is 0.025 mg/m.³
 - Postulated hypothetical accidents must also be considered.
 - Credited prevention/mitigation is required if worker exposures could exceed ERPG3 (4 mg/m³) for workers or ERPG2 (2 mg/m³) for the public.
 - Note: ERPG stands for Emergency Response Planning Guideline. ERPG2 is threshold for injury and ERPG3 is threshold for lasting injury (or worse).
- **Radiological hazard can be significant depending on degree of activation and spallation product content.**
 - Inhaled mercury vapor readily enters the bloodstream.
 - Spallation products in mercury aerosols can cause internal exposure as well.
- **Condensing mercury deeply embeds in virtually all surfaces...see Hg AS A LIQUID.**
 - This action ensures contamination of all components inside the hot cell.

Mercury as a SOLID

- **Mercury freezes at -39°C .**
- **In practice, Hg is generally solid only when combined with other elements.**
- **Mercury is mined in the form of Cinnabar or Mercury Sulfide (HgS). HgS is a very stable chemical decomposed in a furnace at 750°C .**
- **Mercury gas adsorbers typically include sulfur to form HgS.**
 - **Gold amalgamation is also possible for low-volume flows such as process off-gas.**
- **Loose sulfur-containing pellets can be used to absorb spills or capture vapor inside the cell.**
- **Hg daughter products (from activated Hg isotopes) also appear in low concentrations as solid particulates in cell.**

SNS Mercury Related Facilities

Mercury-based target systems require extensive support facilities.

- 1. Mercury Containment**
- 2. Hot Cell / Remote Handling**
- 3. Ventilation / Filtration**
- 4. Waste Handling**
- 5. Water Cooling System**
- 6. Mercury Target Safety Considerations**
- 7. Operational Considerations**

SNS Target Building Layout

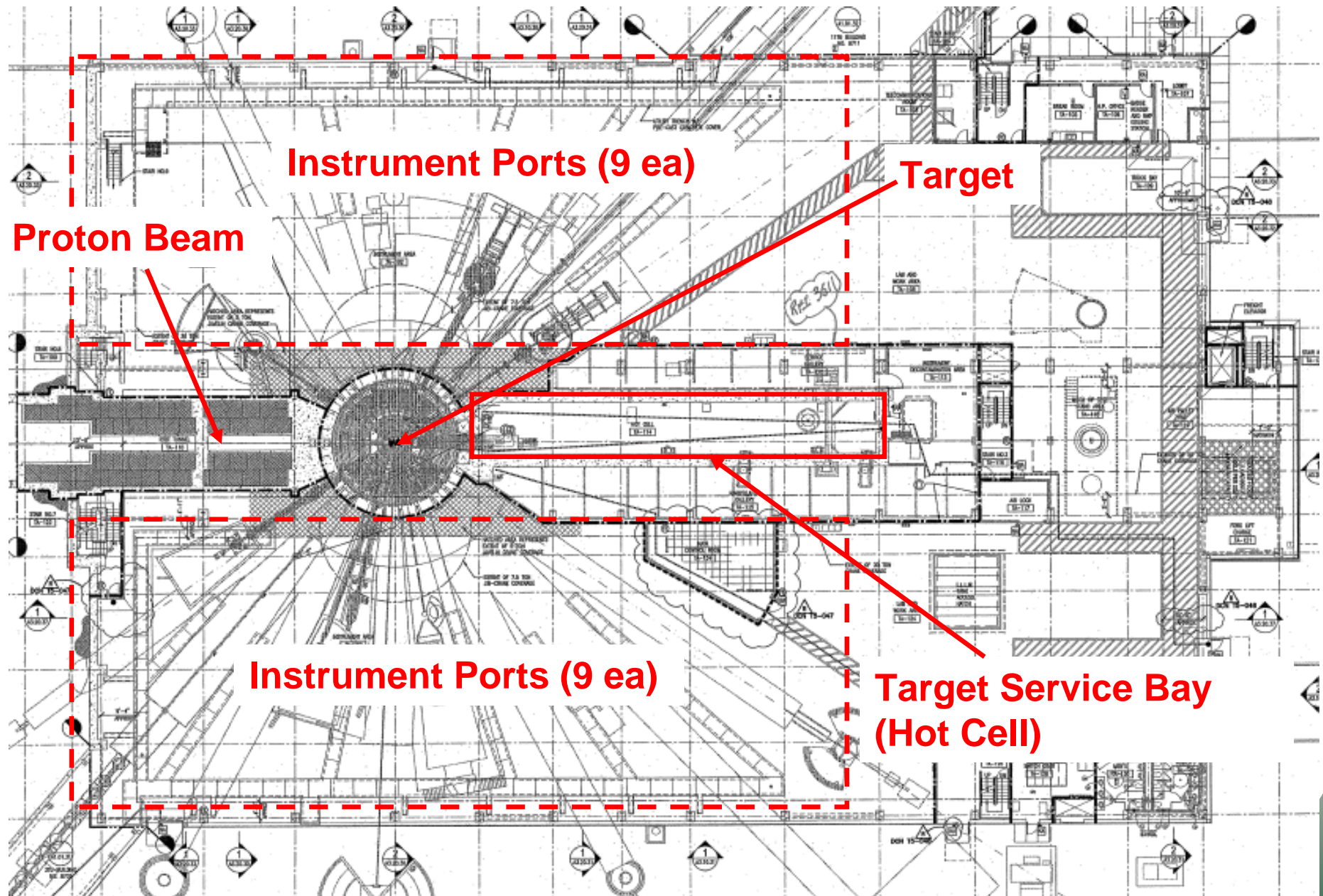

Target Monolith Elevation Cross Section

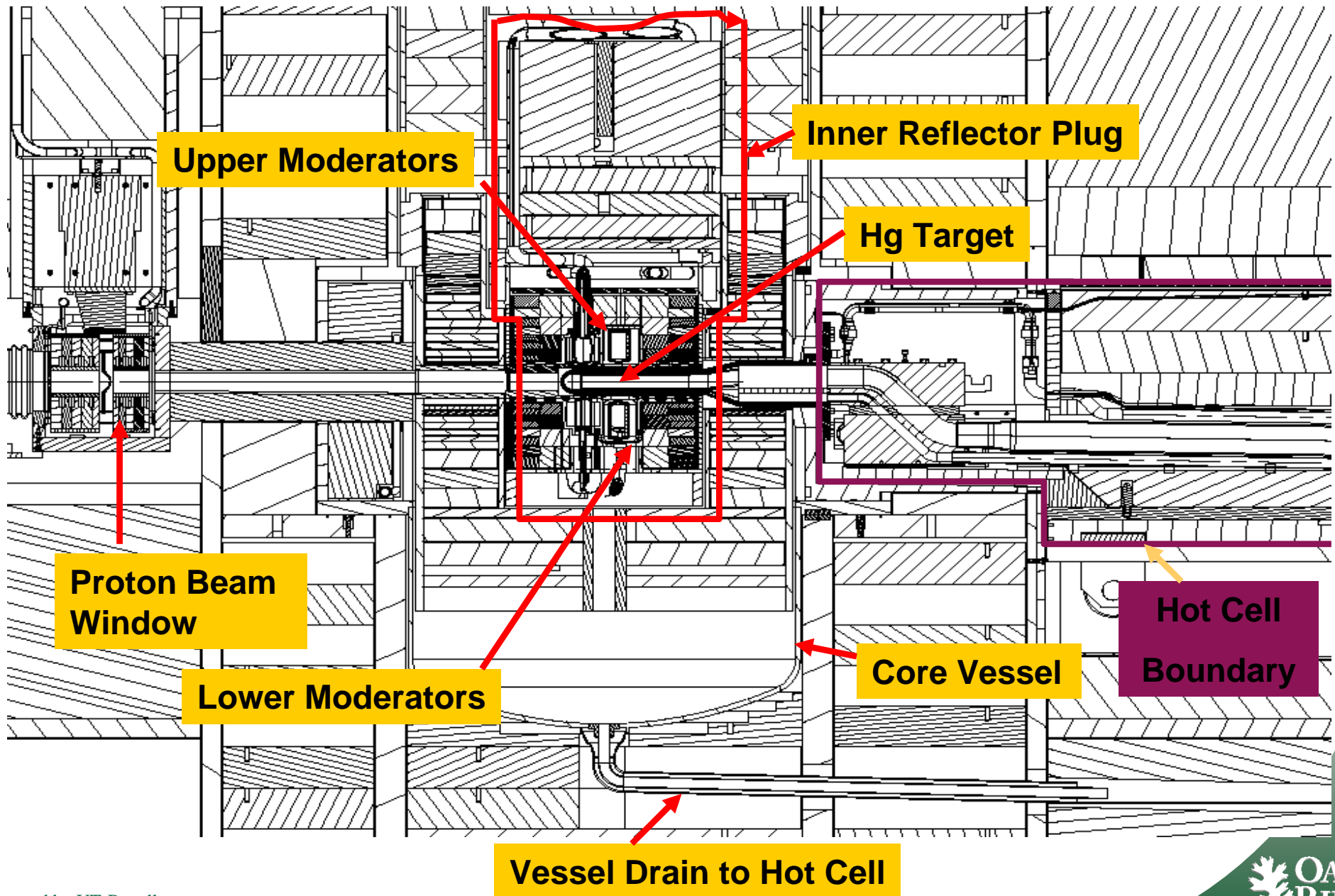

SNS Mercury System Layout

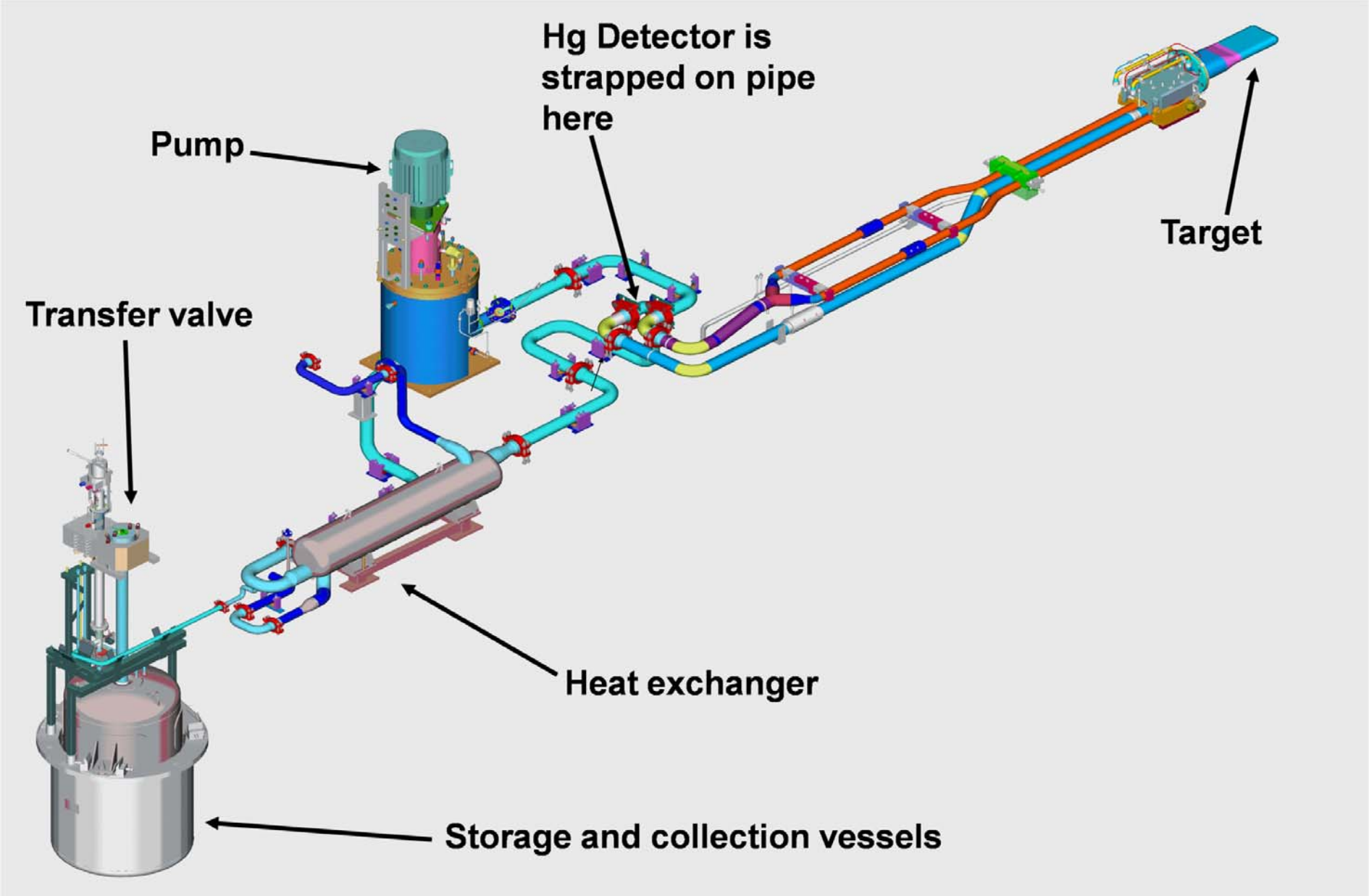

1. Mercury Containment in SNS

- **Rule #1: Mercury must be fully contained.**
- **No leaks are acceptable outside the hot cell.**
 - The portion of the target which extends into the SNS target core vessel outside the cell is doubly contained.
- **Inside the SNS hot cell, mercury leaks are assumed.**
 - Off-gas filtration, a liquid collection system and other measures are used to contain the losses.
- **The SNS target core vessel drain is routed to the hot cell where unlikely target leaks can be collected and returned to the process.**
 - The shielding vessel also has a drainage collection system which can be used to collect an extreme mercury spill.

2. Hot Cell / Remote Handling Considerations

- **All mercury target and process components must be contained, maintained and packaged for off-site disposal inside the hot cell to avoid the spread of mercury.**
- **In SNS, all target change-out and process equipment maintenance is designed to be fully remote.**

Thus,

- **The SNS hot cell is large and the remote tooling systems are highly dexterous.**
- **Roughly 1/3 of the cell is dedicated to the target process and 2/3 is dedicated to remote maintenance.**

SNS Hot Cell Design

- Cell size: 4.3 m x 31.4 m
- 304L Stainless Steel Liner
 - 7 gauge (4.6 mm) thickness on floor
 - 10 gauge (30 mm) on walls
 - 100% welded and leak tested
 - 100% coverage (including roof plugs)
- Two rooms: process cell & “clean” transfer cell
- No personnel entry to process cell
- Bottom loading waste load-out port
- Design cell background is 2 grays/hr
- Equipment assumed to have an integrated radiation tolerance of 1×10^4 grays.
 - This is reasonably achievable using conventional components.

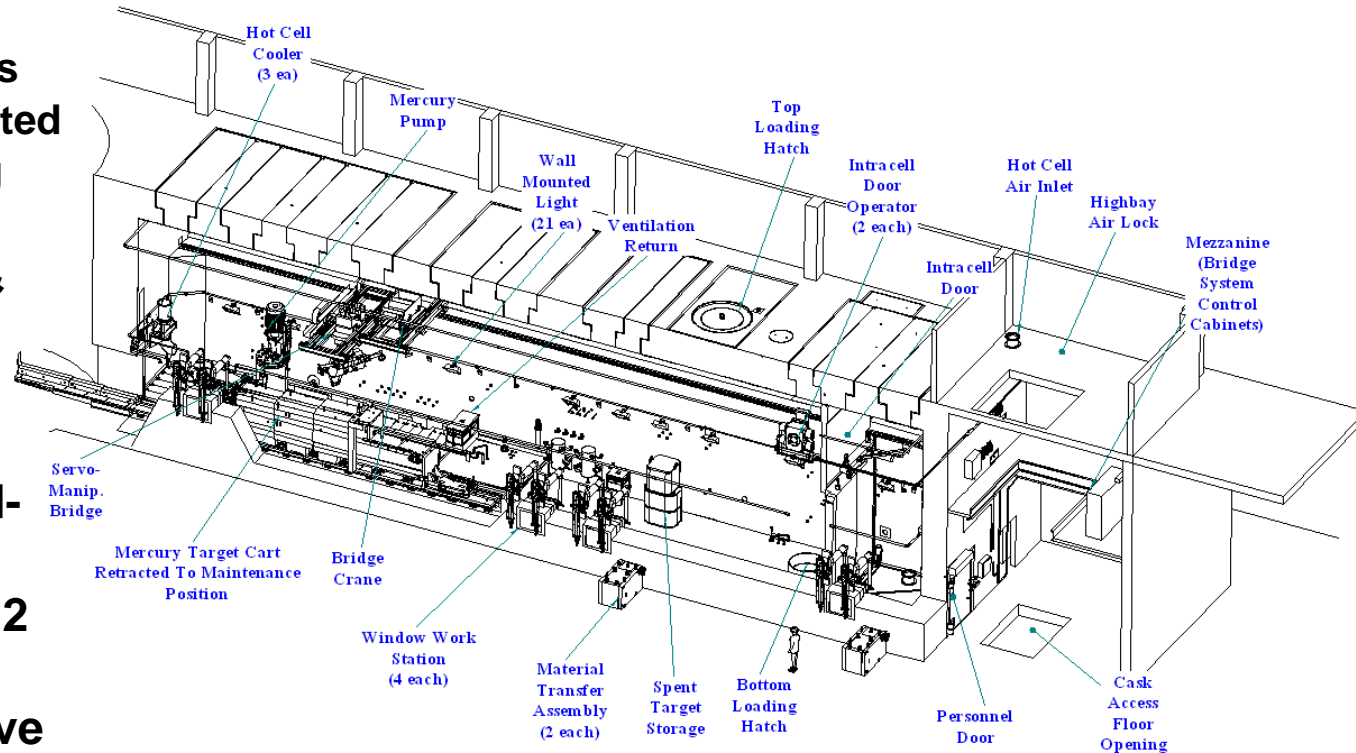

Fundamentals of SNS Hot Cell

The SNS hot cell is the PRIMARY mercury containment boundary for the following reasons:

- **Mercury cannot be completely contained within the process due to maintenance openings and probable operational leaks.**
 - Everything inside the hot cell **WILL** become Hg contaminated, primarily due to vapor transport.
- **Effective decontamination of equipment and tooling inside hot cell is NOT practical.**
 - All used equipment, tools and other waste must be loaded directly into sealed and shielded containers for shipment or storage.
- **SNS has taken the position that personnel will not be allowed inside the hot cell after significant target handling operations have begun.**
 - All operations must be performed remotely.

Mercury Process Equipment Design

- **Use of austenitic stainless steel preferred because it is well-characterized for nuclear applications.**
 - Piping should be limited to <10 dpa radiation damage due to loss of ductility.
 - SNS limits Hg piping temperature to 200°C to avoid chemical corrosion.
- **All SNS mercury process components including piping sections, pipe supports, valves, sensors, etc. are remotely replaceable.**
- **Process is configured to be flat since gravity head is significant.**
 - Increases the size of the hot cell because floor space determines the volume of the cell.
 - The mercury jet requires 30 meters of head so this may not be a consideration in the NF.
- **SNS uses a single sump pump to avoid submerged dynamic seals.**
 - Pump works very well; however careful attention must be given to the monitoring and maintenance of bearings (pump and motor).
- **Other facilities use or propose to use electro-magnetic (EM) mercury pumps.**
 - Not an option for NF due to high discharge pressure requirement



Target Test Facility Hg flow loop during construction

Mercury Process Equipment Design (cont)

- **Block valves are not used in Hg process because it is difficult to stop the large flowing mass.**
 - **The mercury process is designed to be a steady-state operation. The SNS flow rate is determined by pump speed only.**
- **SNS mercury process components are shielded inside the cell to protect cell maintenance and process monitoring equipment.**
- **A mercury dump tank and rapid dump capability (the only mercury wetted valve in the process system) are required for both normal and emergency operations.**
- **A liquid mercury capture and return system is required to reload spilled mercury.**
 - **Up to one liter of mercury is expected to be collected during a normal target change-out.**
- **SNS does not incorporate a mercury purification system.**
 - **Mercury is self-cleaning by plating and gravimetric separation in the collection tank.**

Mercury Process Loop Components

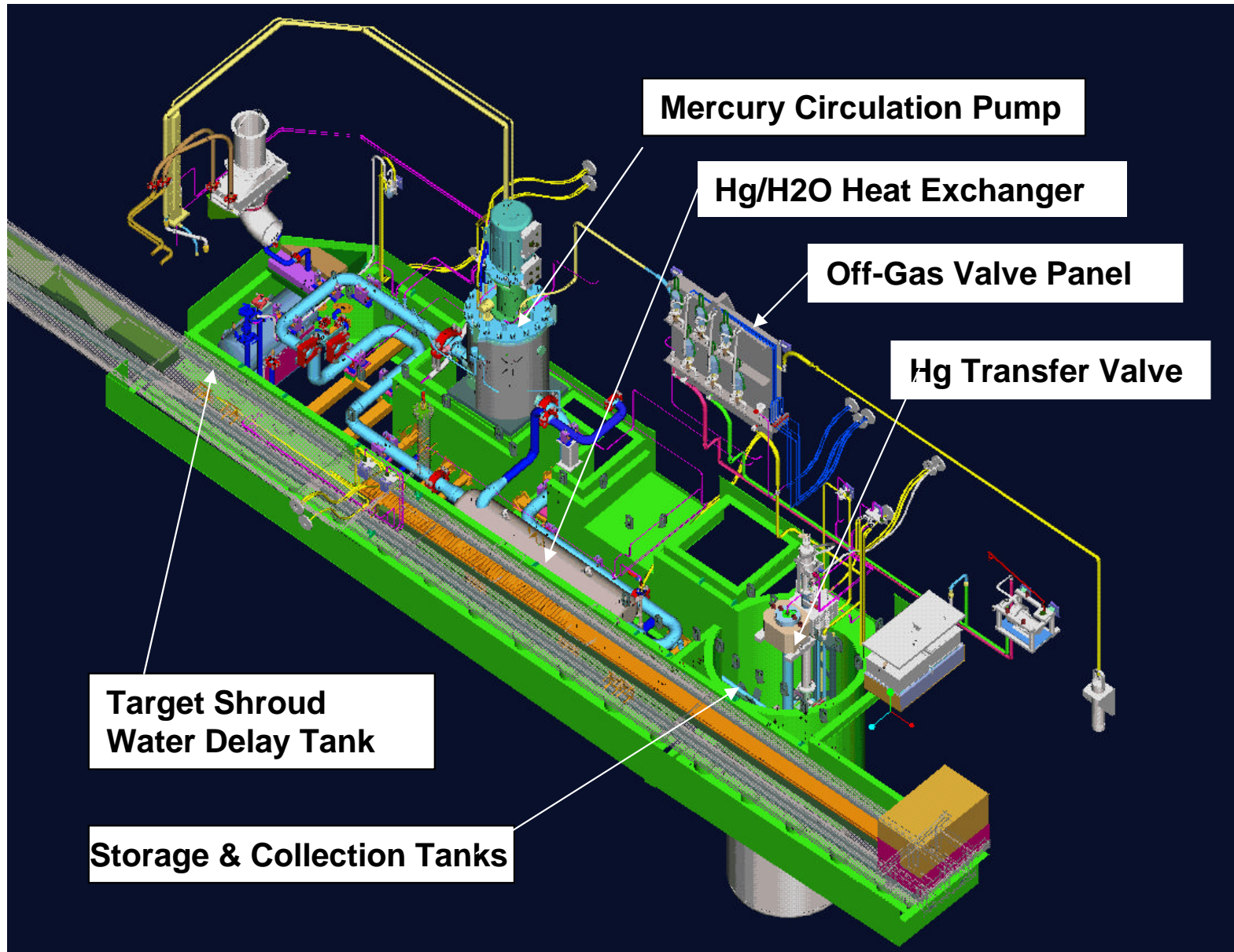

SNS Process Equipment

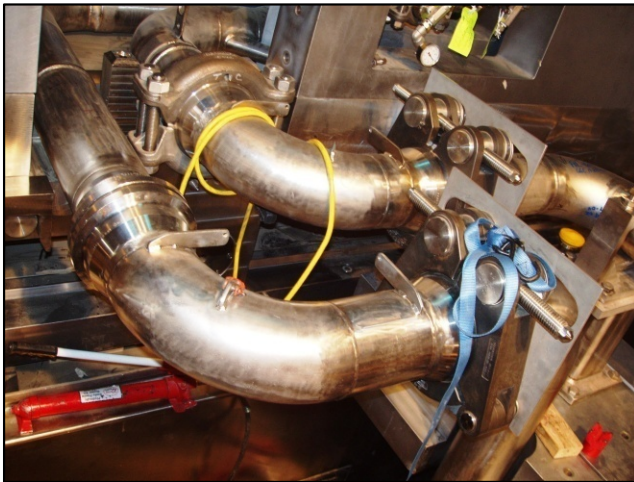

**Remotely-operable
Pipe Coupling**

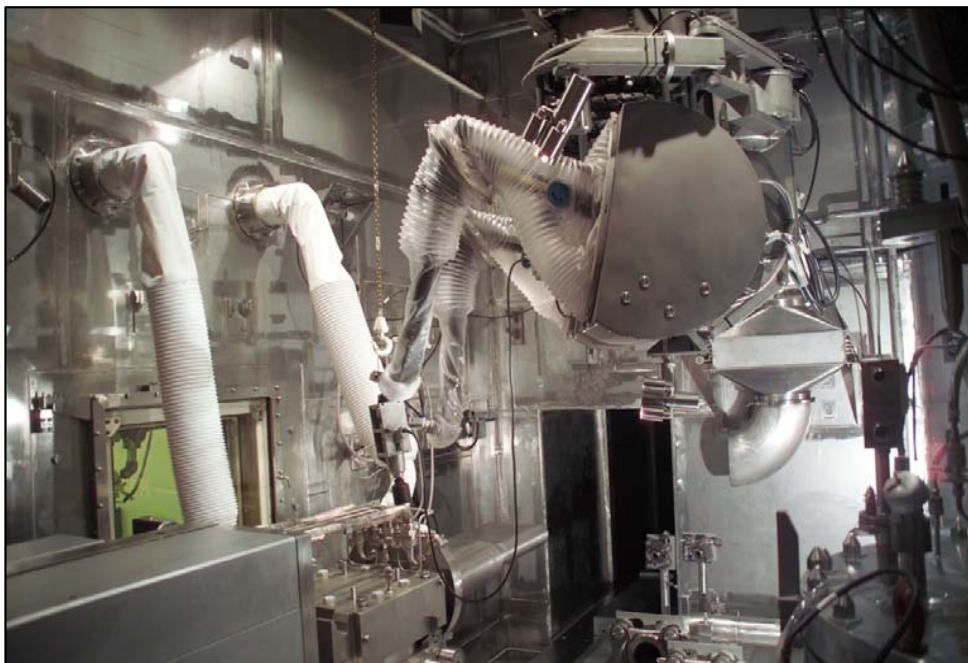

In-Cell Manipulators



Heat Exchanger

In-cell Shielding

- Since the mercury process is a large, distributed source, much of the hot cell interior is exposed with minimal geometric fall-off.
- Significant in-cell shielding (10 cm to 40 cm of steel) is required to protect maintenance and process equipment from excessive radiation.

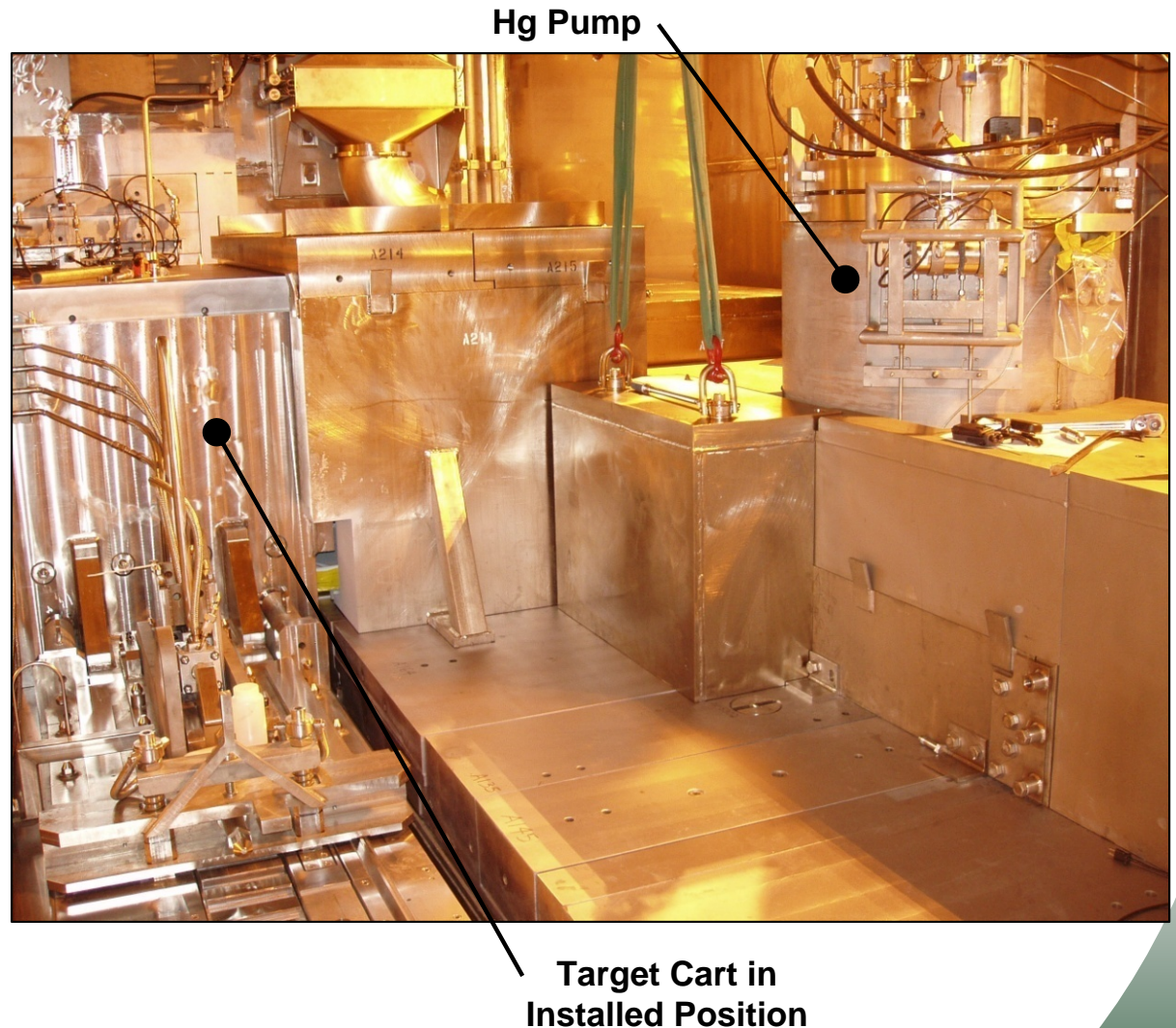

Remote Handling

- The SNS all-remote-handled mercury process is serviced by a dexterous mobile tooling system.
- A smaller scale Neutrino Factory may not require bridge-mounted manipulators but will still require a sophisticated remote maintenance system.



SNS Target Hot Cell

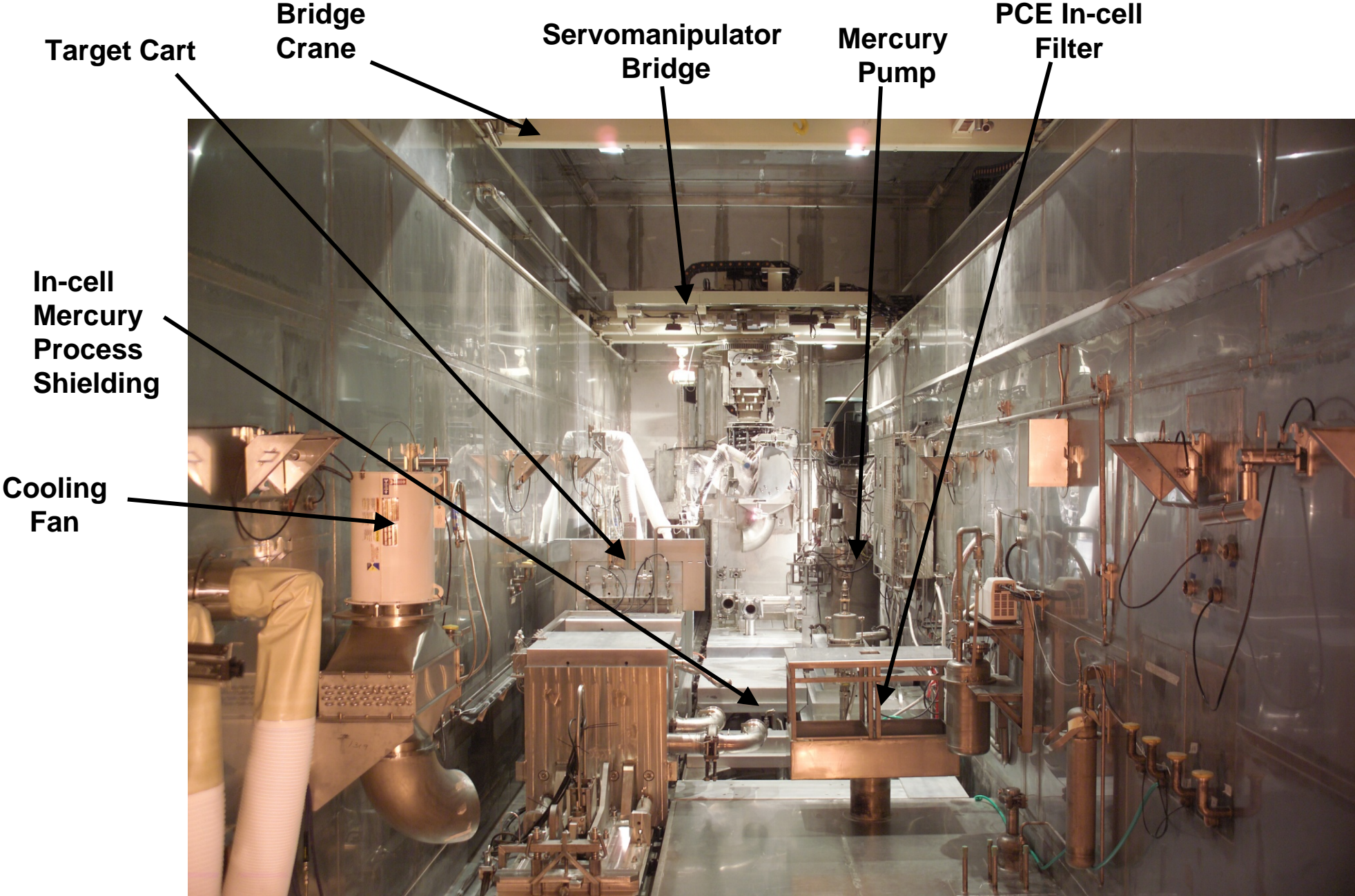

3. Cell Ventilation Design

- **Mercury vapor must be removed from the cell exhaust prior to subsequent conventional particulate filtration (HEPA).**
- **The SNS mercury removal system is based on adsorption on sulfur-impregnated carbon.**
 - **Ventilation air travels thru at approximately 10,600 lpm or 5.6 sec residence time (compared to 0.1 sec in conventional filtering).**
- **Adsorbers are shielded. Change-out is determined by dose rate as well as Hg loading.**
- **Nuclear-grade, double-HEPA particulate filter system with roughing filter and fire screen provided downstream of adsorbers.**

SNS Mercury Adsorber Layout

Adsorber Housing Lid

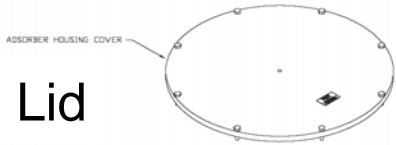

Hoist Ring

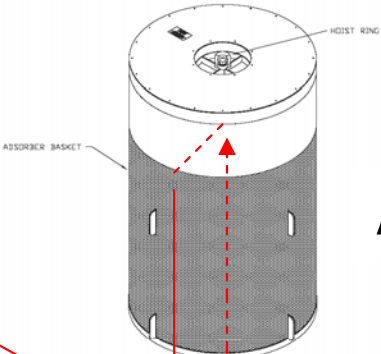

Adsorber Cartridge

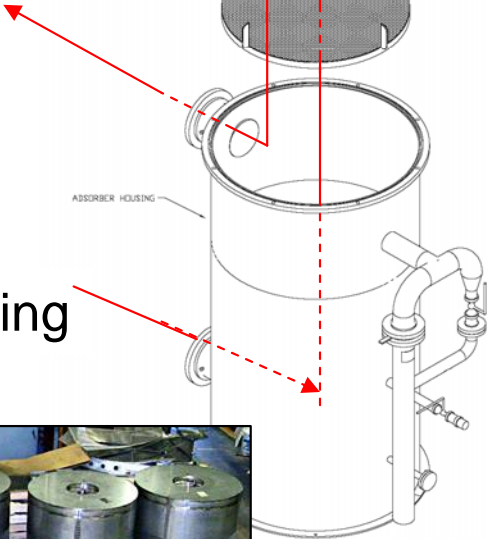

Adsorber Housing



1.2 m dia x
2.5 m high



Plan View of Adsorber Installation

Adsorber Vault: 6 meters 12 meters 4.5 meters high

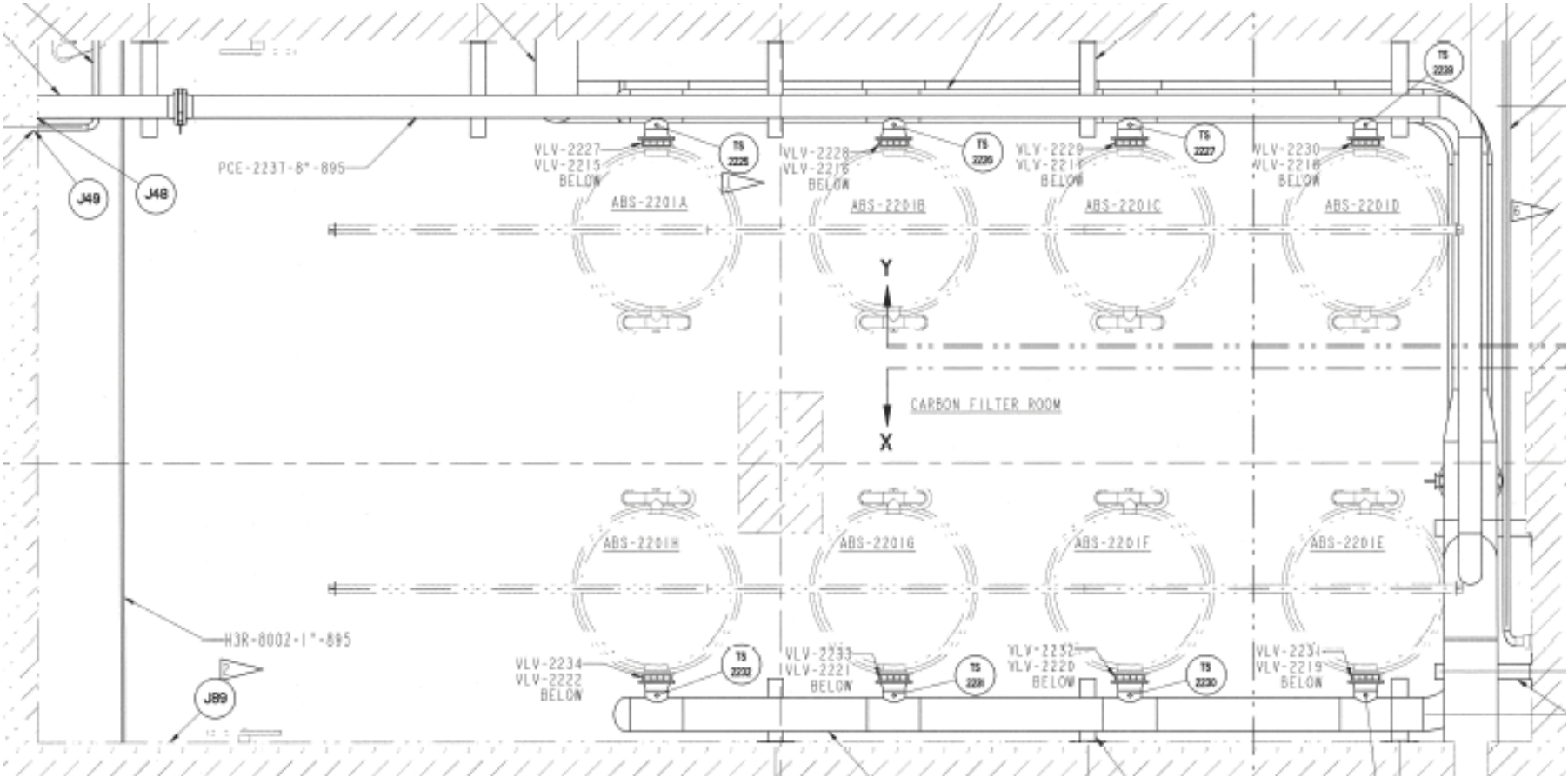

Process Off-gas

- **Proton spallation creates volatile spallation products in mercury**
- **In addition to mercury vapor, off-gas treatment must remove**
 - Noble gases (Kr, Xe)
 - Hydrogen isotopes (including tritium)
- **Will be required for Neutrino Factory**

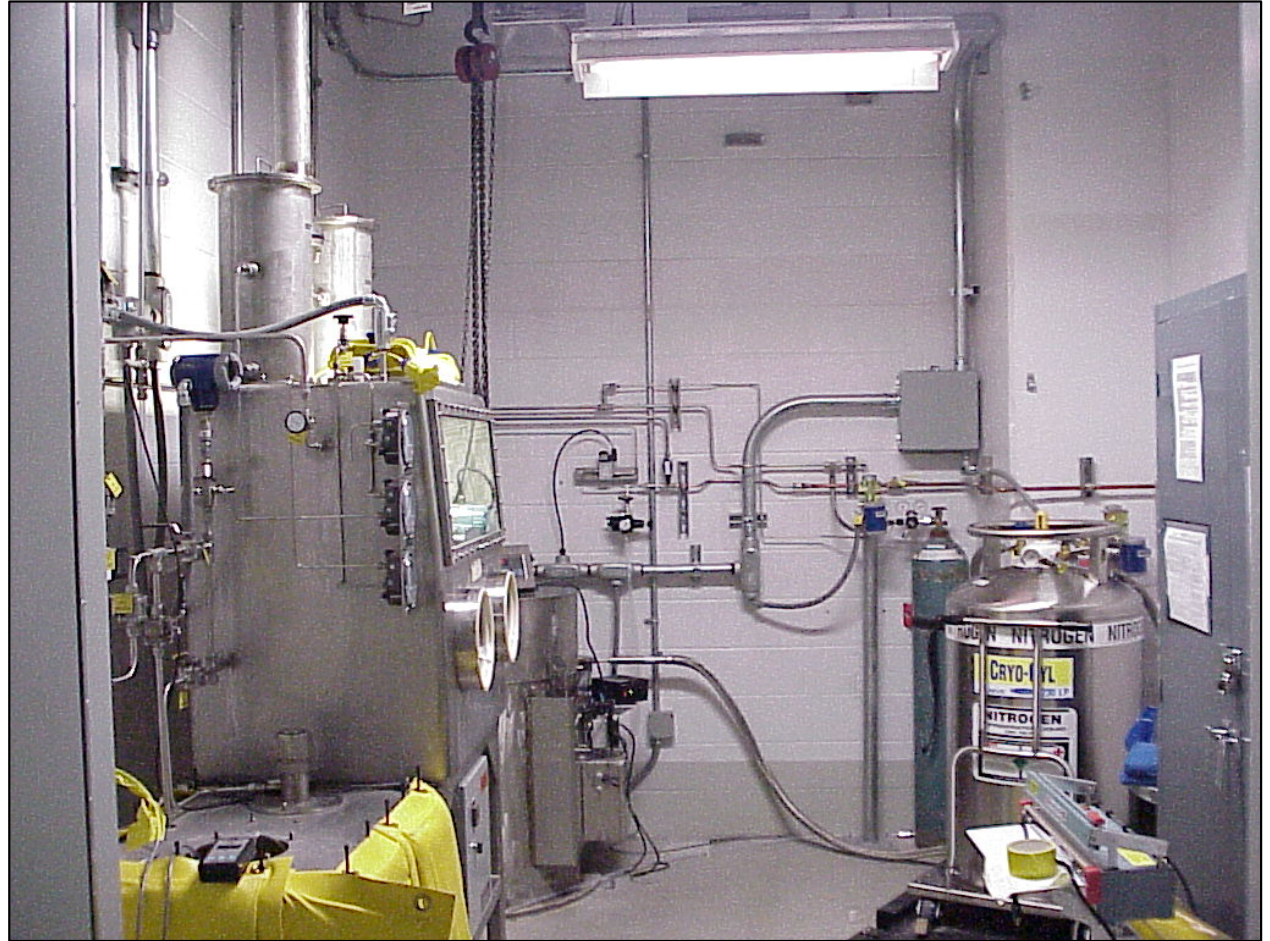

SNS Process Off-gas

- **Process cover gas stream is 100% helium**
- **SNS process off-gas system**
 - Glycol chilled condenser (Hg vapor)
 - 2 stages of gold adsorbers (Hg vapor)
 - CuO oxidation (convert hydrogen to water)
 - Molecular sieve (moisture removal)
 - Cryogenic (77K) charcoal (noble gases)
- **Design flowrate 1.5 scfm (42.5 lpm)**
- **Vented to facility Hot Off-gas System**
 - Double HEPA filters

4. Waste Handling

- **All hot cell and ventilation system waste will be mercury contaminated.**
- **Activated mercury contaminated waste must be fully contained.**
- **In the US, mercury treatment and disposal is governed by the Resource Conservation and Recovery Act (RCRA).**
 - This defines requirements for treatment and disposal of wastes which may contain mercury.
- **Since SNS mercury is radioactive, additional requirements apply.**
 - In the US, this type of waste is called “mixed waste”.
 - Disposal options are VERY limited.

5. Water Cooling Systems

- **The SNS process mercury is cooled with a secondary water cooling system.**
 - **The system is sized to remove 1.2 MW of power or ~60% of the proton beam power (at 1.0 GeV).**
- **Maximum mercury temperature (90°C) is controlled to prevent boiling of the cooling water.**
- **The water cooling system is constructed using commercially available components located in a vault outside the hot cell.**
- **Because this water is not exposed to the proton beam, maintenance is performed hands-on immediately after beam shutdown.**
- **To contain mercury in the hot cell, a double-walled heat exchanger with a monitored interstitial gap is used.**
- **Ion Exchange Columns and Water Filters are locally shielded.**
- **The SNS target water cooling systems have been essentially 100% reliable.**

Typical Activated Water Cooling Loop

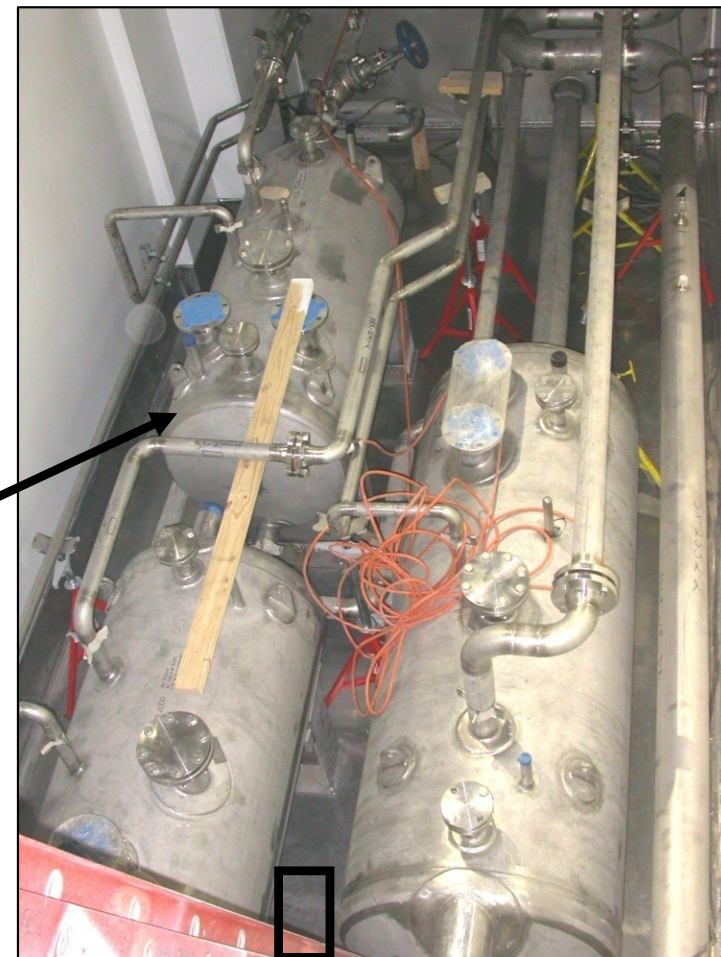
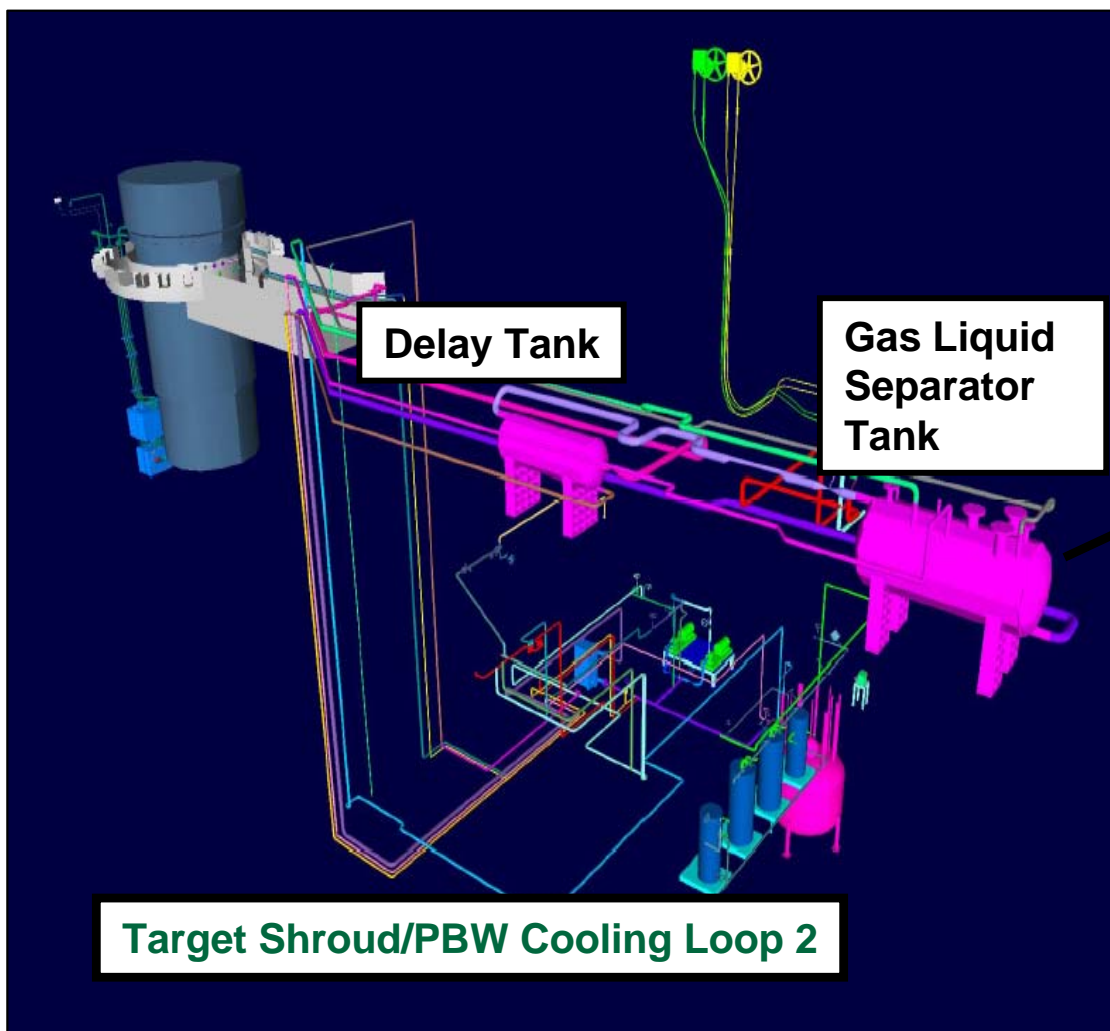

GLS Tanks Loops 2, 3, & 4

NOTE: The mercury cooling loop does not need a delay tank

Secondary Target Water Cooling System



6. Mercury Target Safety Considerations

- **Accelerator safety order requires hazard and accident analyses to ensure workers, the public, and the environment are protected against hazards such as mercury toxicity and radioactivity**
 - **Comprehensive hazard analysis to identify mishaps and off-normal conditions that require credited engineered or administrative controls**
 - **Accident analysis as needed to demonstrate effective mitigation of worst-case hazard**
- **SNS hazard and accident analyses identified credited controls including:**
 - **Concrete walls of the hot cell help ensure Hg confinement**
 - **Seismic qualification**
 - **Fire barrier**
 - **Maintain pressure differential**
 - **Double wall separation between Hg and utilities that extend beyond hot cell boundary (e.g. Mercury/Water Heat exchanger)**
 - **Safety-rated instrumentation to prevent beam operation at off-normal Hg flow rates and/or when cooling lost**

7. Mercury Target Operational Issues

- **The SNS mercury target system has proven to be extremely reliable.**
- **Major operational considerations associated with a mercury process.**
 - **TARGETS:** Mechanical change out of a mercury target module is similar in nature to a similar solid target.
 - **PROCESS EQUIPMENT:** Remote handling requirements of mercury pump, HX and piping are complex and will result in significant maintenance downtimes times and general operational risk.
 - Failed mercury components cannot be repaired in-situ, full assemblies must be replaced.
 - It is difficult to incorporate redundant mercury process elements (pump, HX, monitors, valves) due to increased cell volume requirements and the need for more valving. Redundancy may actually make the process less reliable.
 - **MAINTENANCE EQUIPMENT:** Maintenance and monitoring of remote tooling is significant operational cost, frequently greater than the operational costs associated with the process.

Summary and Conclusions

- **Hg targets are feasible, but there are significant facility and safety implications.**
- **All physical phases of Hg must be considered in equipment and hot cell design.**
- **Visit ORNL for further insight and information.**