

Magnet/Syringe Separation Issues
V.B. Graves
8/12/05

This document is an initial response to the results of Peter's analysis on the attractive forces between the magnet and the steel hydraulic cylinders in the baseline syringe pump design.

Based on the conversations I have had with hydraulic integrators, aluminum cylinders are not practical at the intended operating pressures and are not an option for the Hg cylinder in any case. It appears the only solutions to this problem are to either use all-stainless cylinders or separate the cylinders from the magnet. Since the cost of stainless cylinders is prohibitively high, the practical solution is to increase the distance between the magnet and the cylinders. While Peter's analysis indicated that 1m would be a sufficient separation distance, in our subsequent phone conversation we thought that a separation distance of 2m might be preferred as a conservative approach to the analysis results, and my comments below reflect that value. The final value is TBD.

To minimize changes to the current design (Fig. 1) this separation would most easily be accomplished by increasing the length of the flexible hoses between the sump tank and the target module, keeping the sump tank and cylinders inside a secondary container box. The secondary bellows surrounding the Hg supply and return lines would necessarily lengthen as required. Conceptually this is shown in Fig. 2. This change has several implications on the design, some positive in nature and some negative. I have listed some of these below, but I'm sure that more will develop as the redesign progresses. *Those issues that deal with the cylinders must be resolved prior to the syringe pump procurement.*

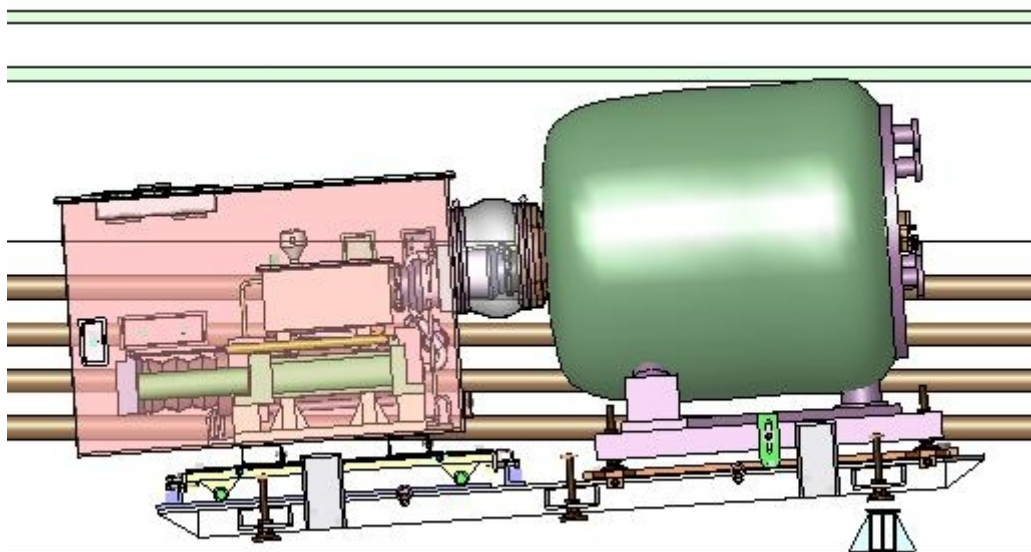

Fig. 1. Existing Design

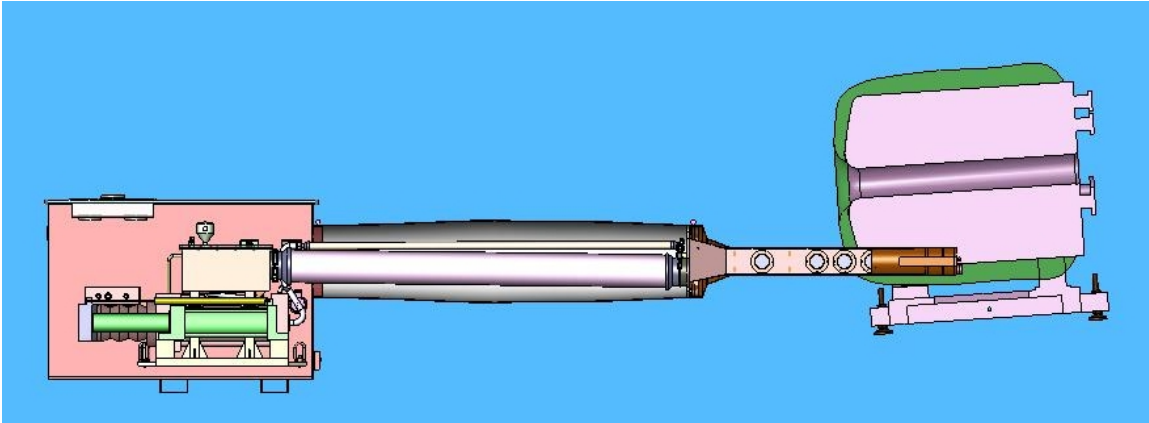

Fig 2. Separated System (use your imagination to insert the target module into the magnet). Magnet elevated to beam height, syringe system on floor. Intermediate hose supports not shown.

Baseplate

- The common baseplate cannot be extended 2m in length due to the fixed beam elevation and facility constraints both at MIT and CERN. This implies that a common baseplate is not needed. However, it is still required that the magnet be elevated, tilted, and aligned with the beam, so some sort of magnet baseplate will be necessary. Because it already incorporates a means to perform alignment adjustments, one option would be to shorten the current baseplate so that it only supports the magnet.
- With flexible hoses, the syringe does not have to be tilted and may sit directly on the floor (or a mobile baseplate).
- The syringe system no longer has to be directly in line with the magnet or beam, which would allow some flexibility in positioning. This may be beneficial during integrated tests at MIT.
- With 2m of flex hose, the target module might be manually inserted into magnet, so syringe system does not require rolling cart. Estimated weight of the target module is 100-150 lbs.

Cylinders

- With no magnetic attraction forces to deal with, carbon steel cylinders, rods, and pistons can be used in the drive cylinders. The Hg cylinder will still be designed for water service (i.e., chrome plating cylinder walls, piston, rod)
- Because the syringe is no longer interfaced to the magnet through the common baseplate, minimizing the syringe length is no longer a driving requirement. The Hg cylinder diameter could decrease from 10" to 8", putting it in the "low-cost" family of cylinders. With an 8" Hg cylinder, maintaining the 12-sec jet requirement will increase the required stroke by 8" and the total extended length by approximately 13".

Extended Hoses

- Added flex hose will require support to prevent sag due to Hg weight.
- Flexible hoses have internal convolutions that will trap Hg in these slightly-sloped hoses and will have more flow resistance than rigid pipe. For flow reasons, it would be preferable to use rigid pipe for most of the new length with flex hoses on one or both ends. Use of 2m of rigid pipe makes it impractical to ship and transport assembled system (syringe, pipe, target module), so assembly and disassembly of the primary containment would be required at MIT and CERN. However, the use of rigid pipe is not absolutely required, and the desire to not open the primary containment in the MIT and CERN facilities probably overrides the flow issues.
- Pressure drop across 2m of new pipe will be calculated; increasing pipe diameter reduces pressure drop but would require additional Hg inventory.
- Additional length of pipe requires additional Hg inventory to pre-fill supply line prior to syringe actuation (2m of 1" pipe will require approx 1 additional liter). Some slightly increased amount of cylinder stroke will be lost to pre-filling the additional volume.
- The 6" diameter Hg return hose is fairly expensive (\$2100 for 18.25 inches), so adding another 1.5m is not an insignificant expense. I will probably go with a smaller diameter hose for the return line.
- Since they interface through the secondary containment box, hydraulic lines, sensor wires, ?scintillator?, and optic fiber bundles will have to be longer since they will be further from the TT2/TT2A junction. The fiber bundles and scintillator cables will be inside the flexible secondary containment along with the Hg supply and return lines.

Target Module

- Because the syringe pump & containment box would be positioned below the beam, the downstream secondary beam window would move to the target module rather than the secondary containment box.
- Downstream end of target module would require changes to accommodate different secondary containment.
- Supporting the target module off of the secondary containment box from 2m away is not practical (see Fig. 3). Secondary containment baseplate could have provisions for storage of target module.

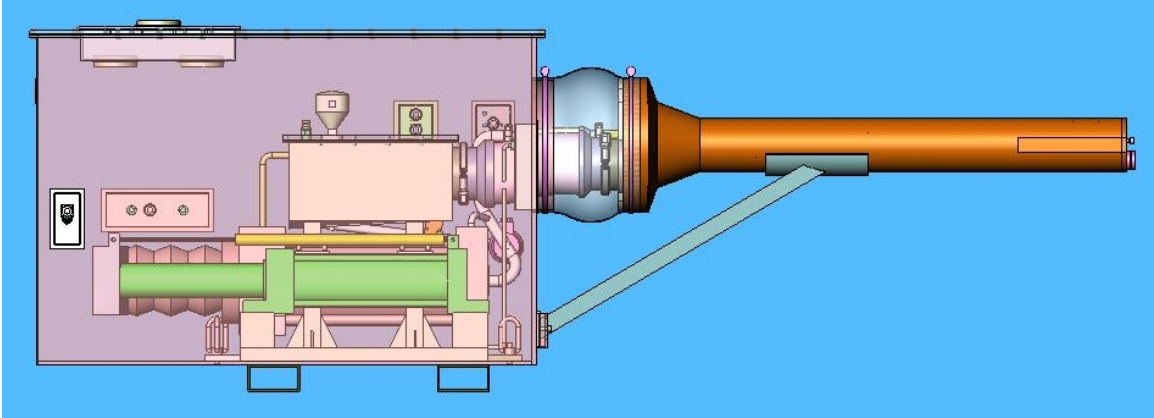

Fig. 3. Existing target module bracing method