

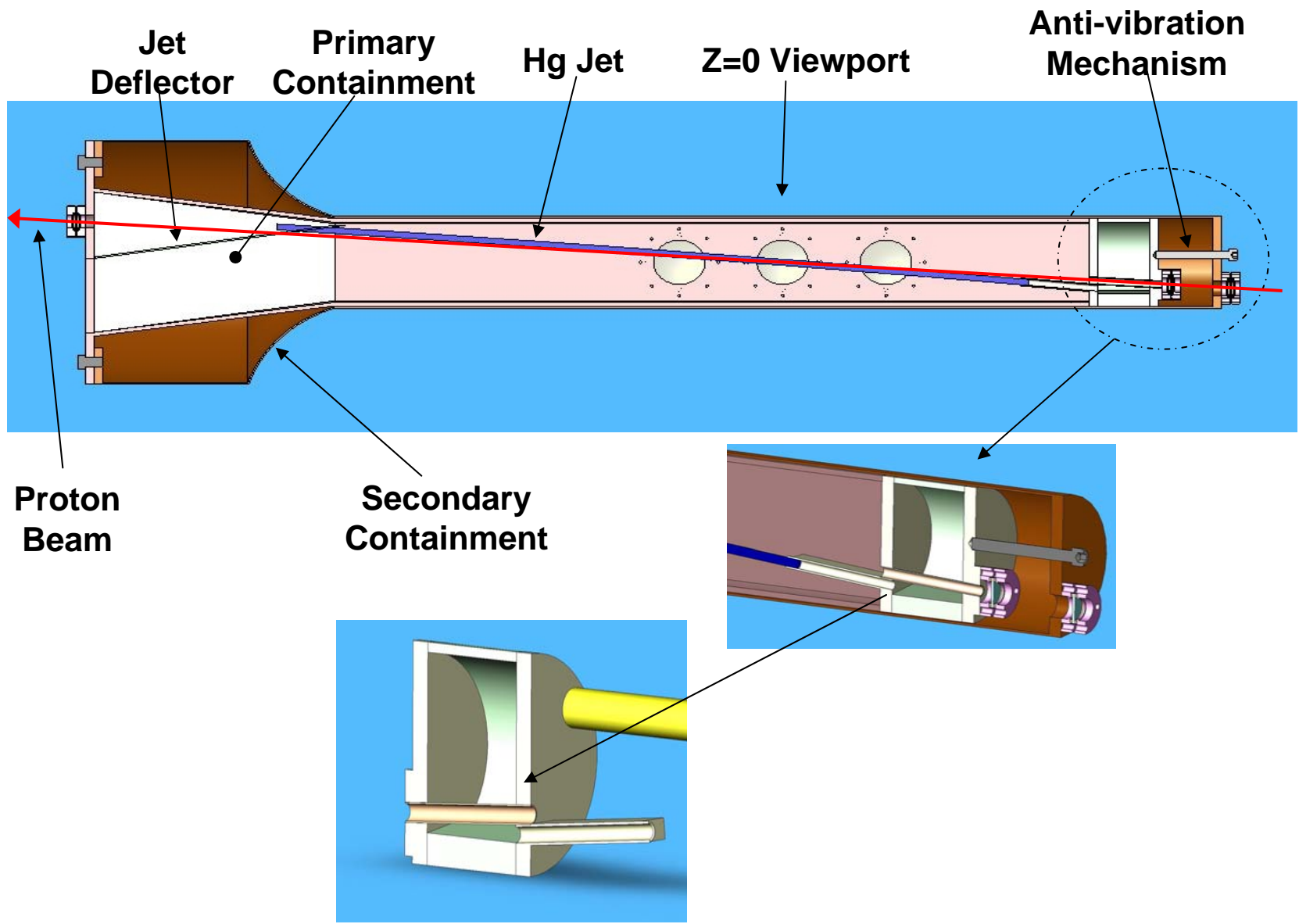

MERIT Experiment Window Study

N. Simos, BNL
Van Graves, ORNL

Original Baseline Target Concept



Baseline Target Assembly Concept

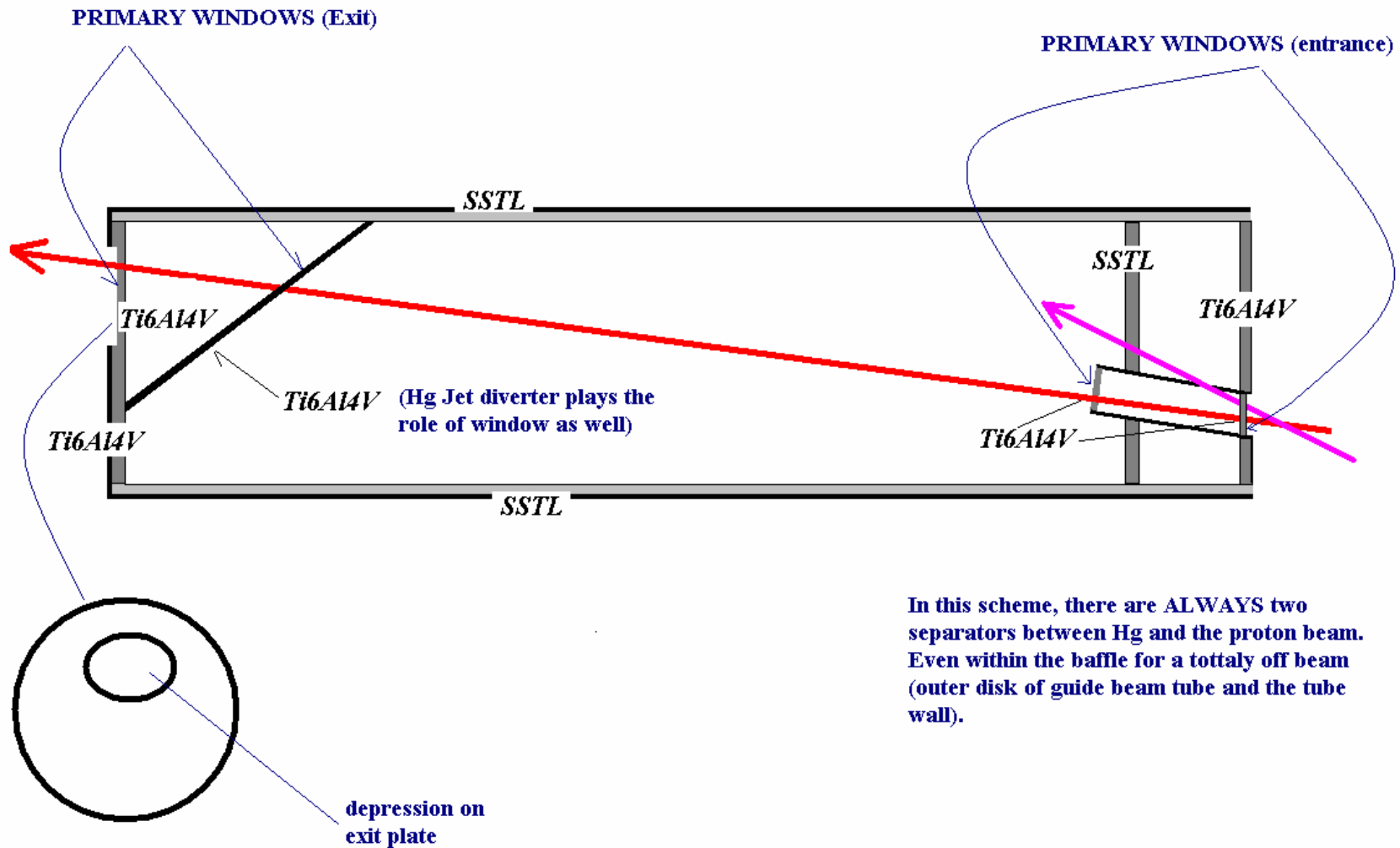

In this scheme, there are ALWAYS two separators between Hg and the proton beam. Even within the baffle for a totally off beam (outer disk of guide beam tube and the tube wall).

Baseline Beam Window Concept

DOUBLE Primary Window

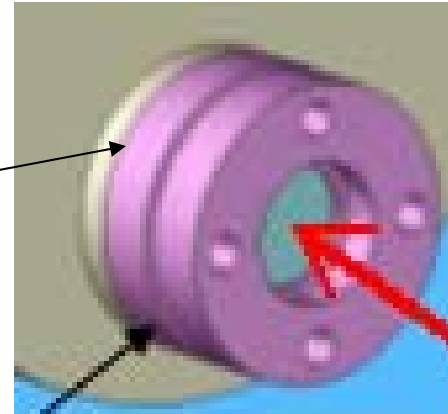
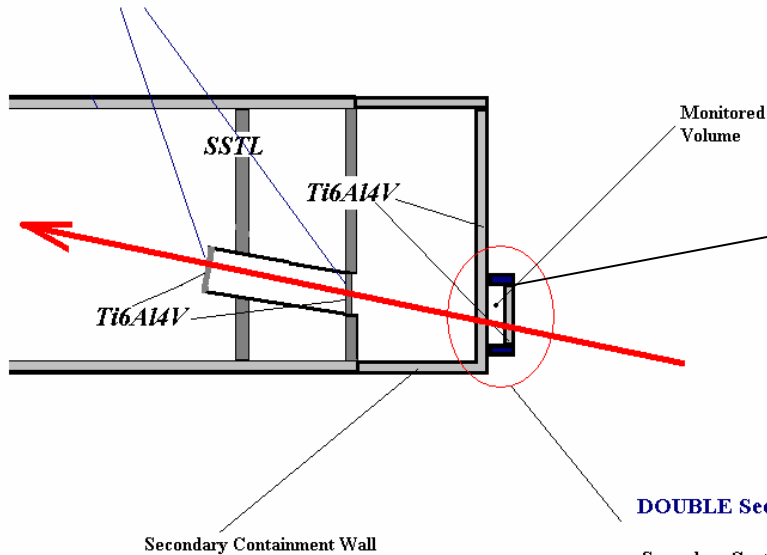

DOUBLE Secondary Window

Secondary Containment Wall becomes the inner disk of the double secondary window. Both (secondary wall and outer window disk made of Ti-6Al-4v)

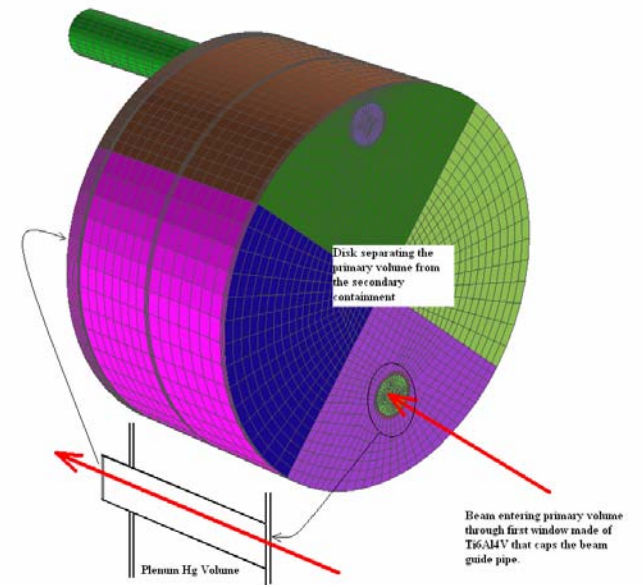
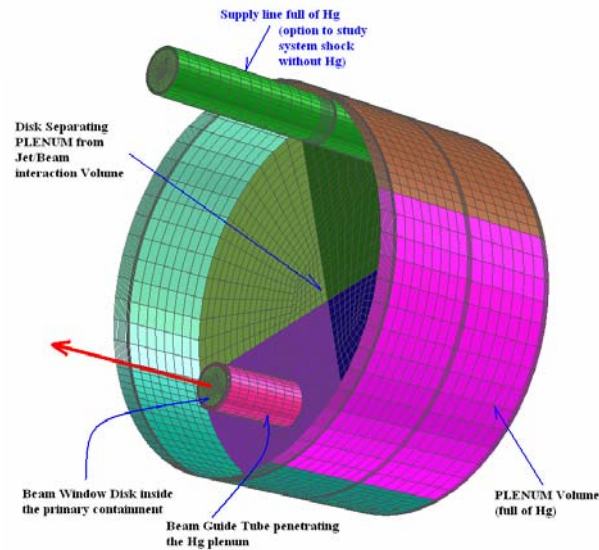
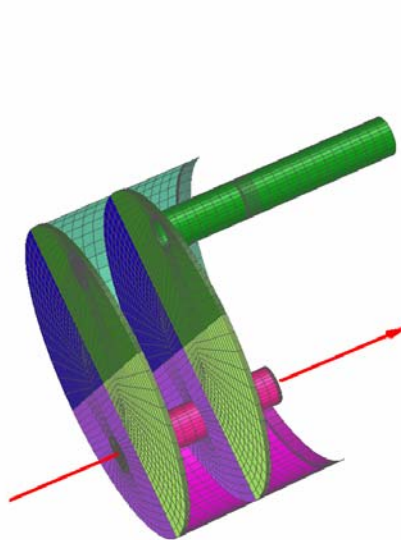

NEW Baseline Target Concept

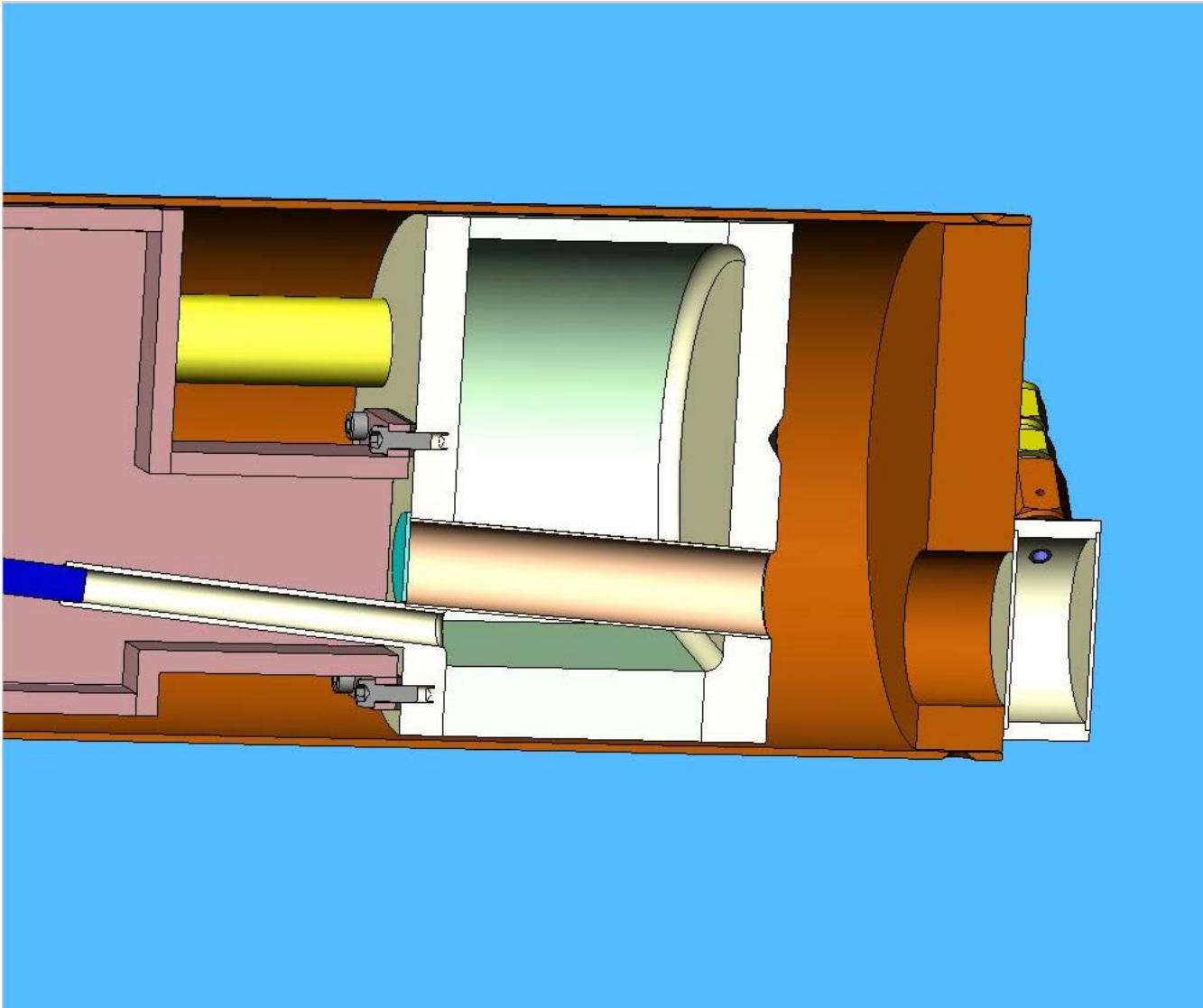

NEW Baseline Target Concept

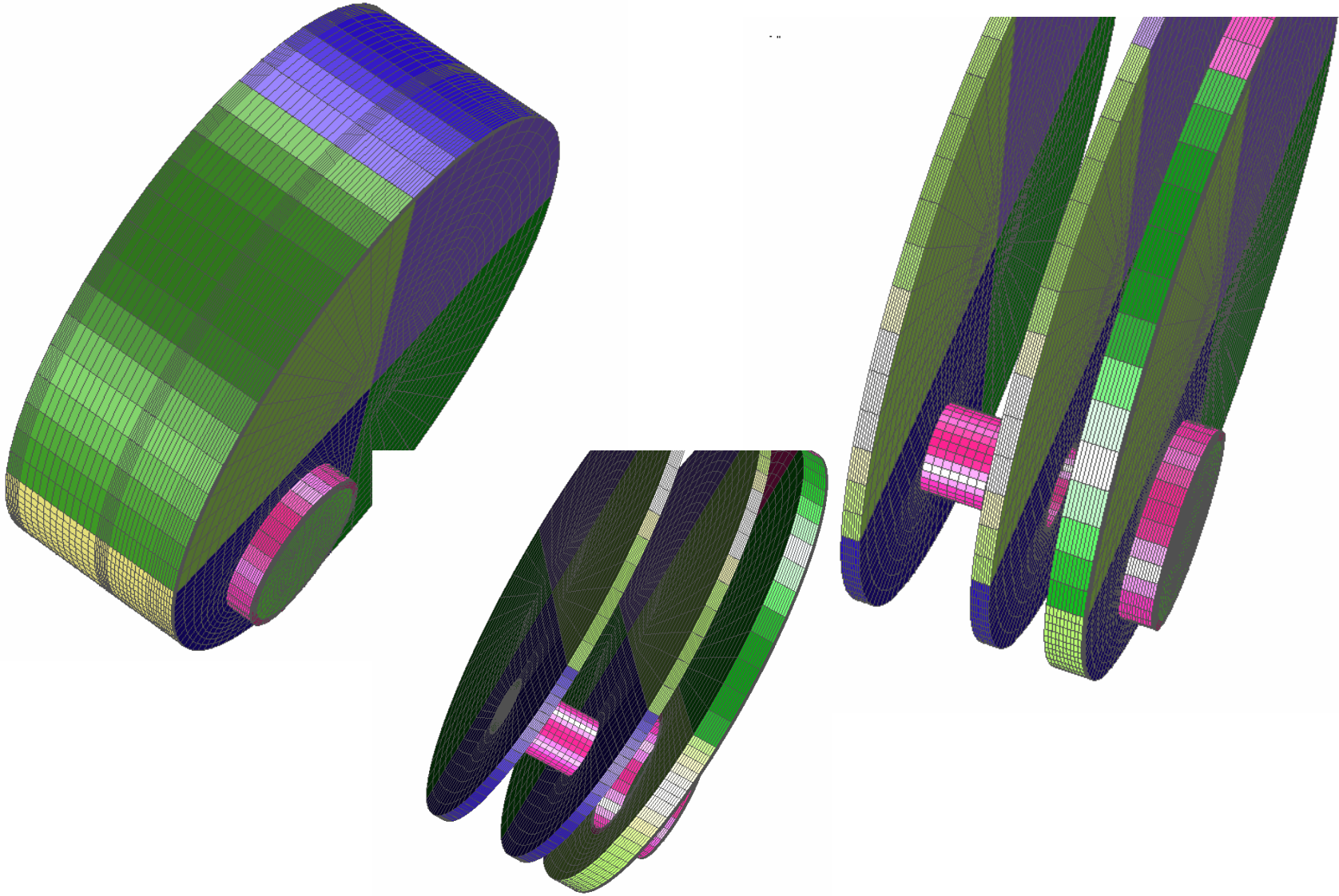

NEW Baseline Target Concept

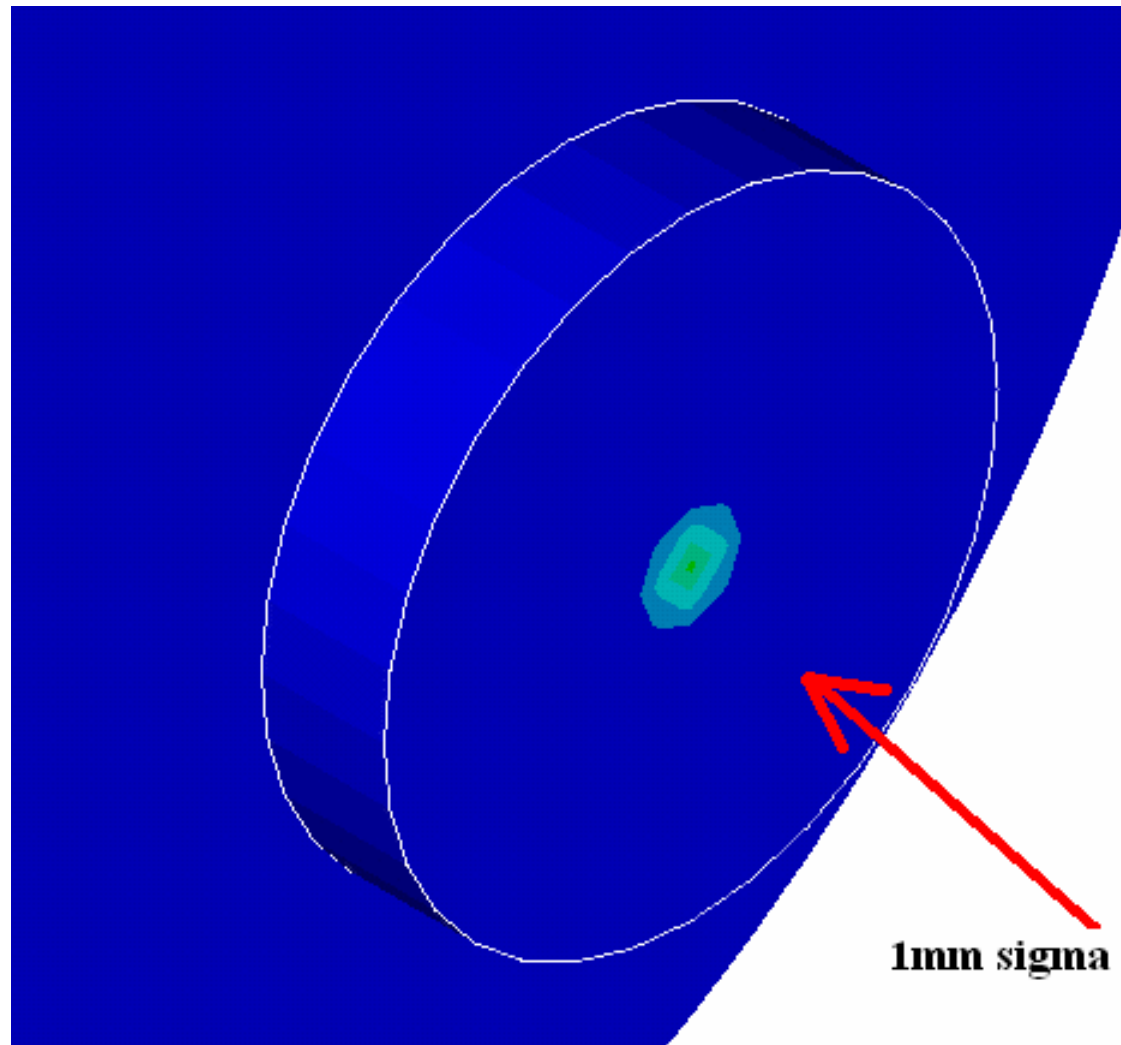

CONCERNS realized in E951 experiment

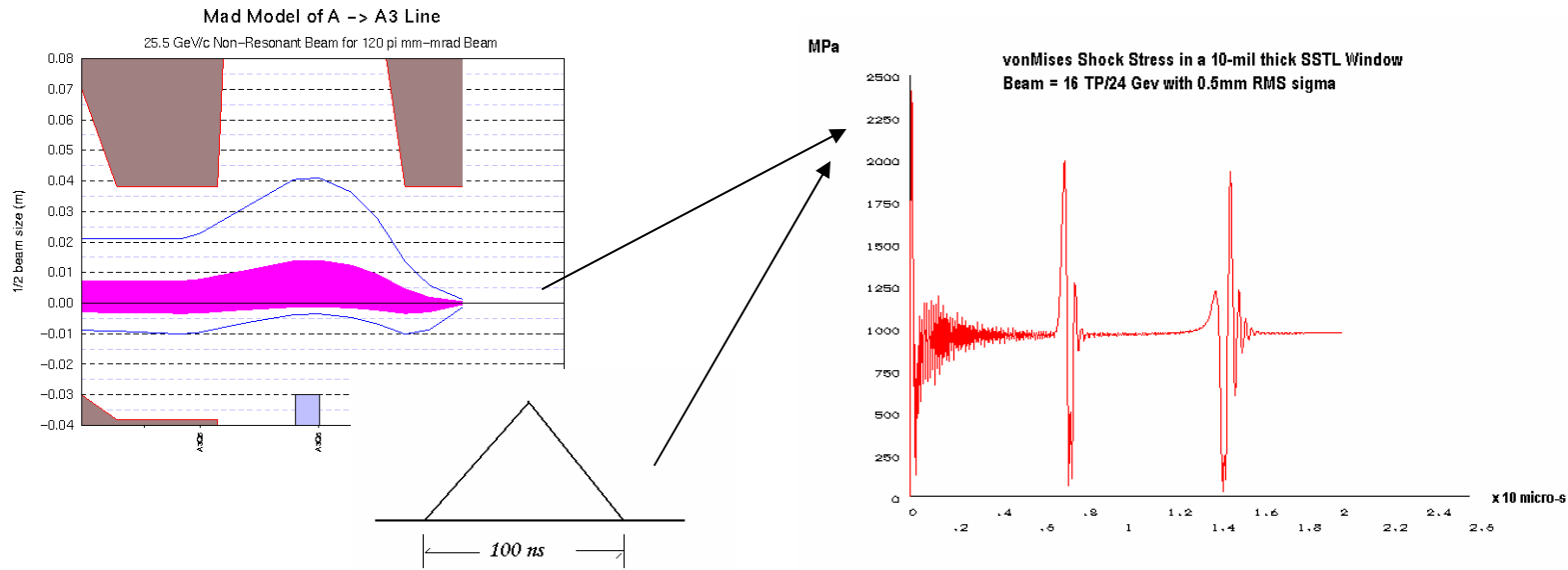
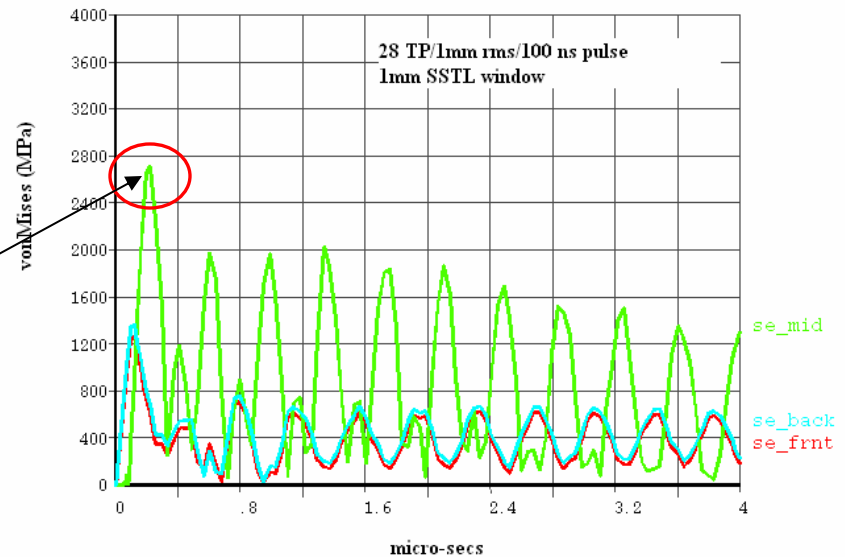

Figure above depicts the tight beam spot requirement (0.5 x 0.5 mm rms) for target experiment at AGS

Induced shock stress in a window structure by 16 TP intensity beam and the spot above will likely fail most materials in a single short pulse (~ 2 ns)

MERIT Experiment Issues with SSTL Windows



The composition of Ti6Al4V Grade 5

Fabrication

- Weldability – Fair
- Forging – Rough 982°C (1800°F), finish 968°C (1775°F)
- Annealing – 732°C (1350°F), 4hr, FC to 566°C (1050°F), A.C. F.C. not necessary for bars
- Solution Heat Treating – Forgings
- Ageing – 904-954°C (1660-1750°F), 5 min-2hrs, W.Q. 538°C (1000°F), 4hr, A.C.

	Content
C	<0.08%
Fe	<0.25%
N ₂	<0.05%
O ₂	<0.2%
Al	5.5-6.76%
V	3.5-4.5%
H ₂ (sheet)	<0.015%
H ₂ (bar)	<0.0125%
H ₂ (billet)	<0.01%
Ti	Balance

Ti-6Al-6V tested as beam window with the 24 GeV AGS Beam (3.5 TP)

Physical Properties

Typical physical properties for Ti6Al4V.

Property	Typical Value
Density g/cm ³ (lb/ cu in)	4.42 (0.159)
Melting Range °C±15°C (°F)	1649 (3000)
Specific Heat J/kg.°C (BTU/lb/°F)	560 (0.134)
Volume Electrical Resistivity ohm.cm (ohm.in)	170 (67)
Thermal Conductivity W/m.K (BTU/ft.h.°F)	7.2 (67)
Mean Co-Efficient of Thermal Expansion 0-100°C /°C (0-212°F /°F)	8.6x10 ⁻⁶ (4.8)
Mean Co-Efficient of Thermal Expansion 0-300°C /°C (0-572°F /°F)	9.2x10 ⁻⁶ (5.1)
Beta Transus °C±15°C (°F)	999 (1830)

Mechanical Properties

Typical mechanical properties for Ti6Al4V.

Property	Minimum	Typical Value
Tensile Strength MPa (ksi)	897 (130)	1000 (145)
0.2% Proof Stress MPa (ksi)	828 (120)	910 (132)
Elongation Over 2 Inches %	10	18
Reduction in Area %	20	
Elastic Modulus GPa (Msi)		114 (17)
Hardness Rockwell C		36
Specified Bend Radius <0.070 in x Thickness		4.5
Specified Bend Radius >0.070 in x Thickness		5.0
Welded Bend Radius x Thickness	6	
Charpy, V-Notch Impact J (ft.lbf)		24 (18)

Beam Window Study on T-6Al-4V and Thickness Requirement

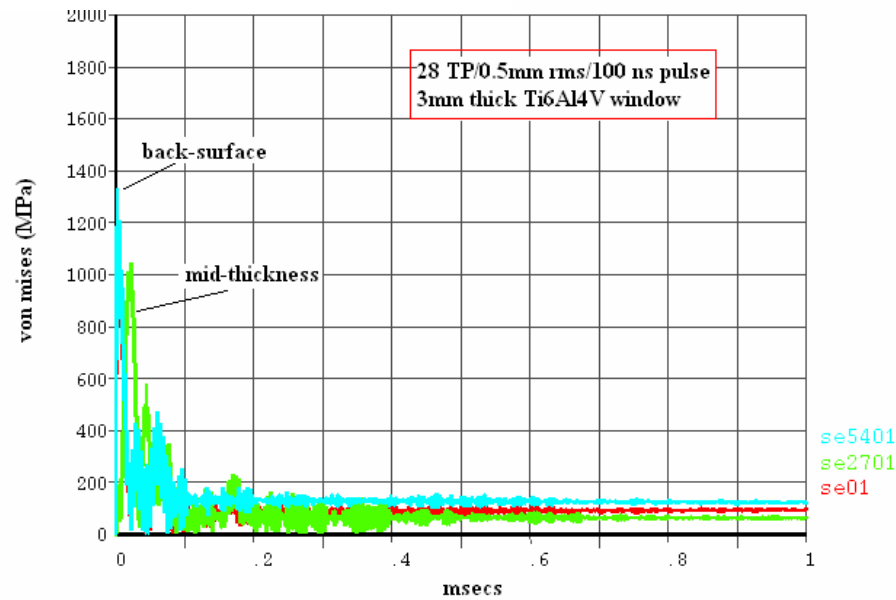
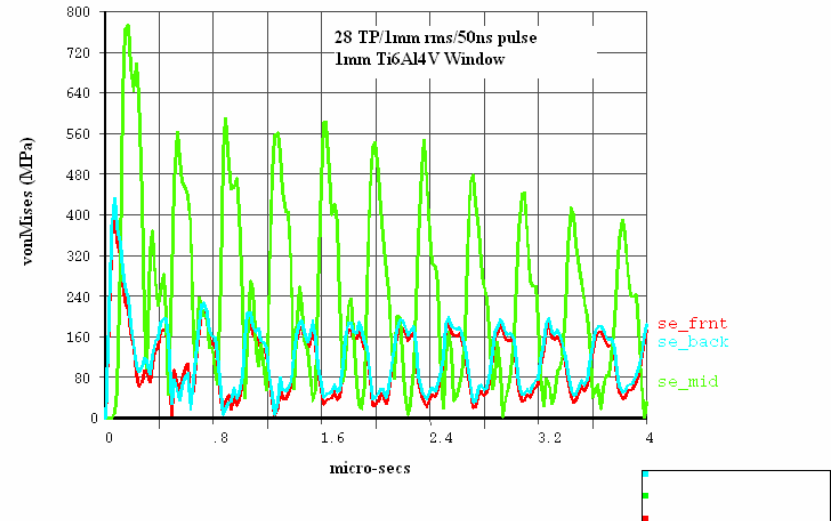
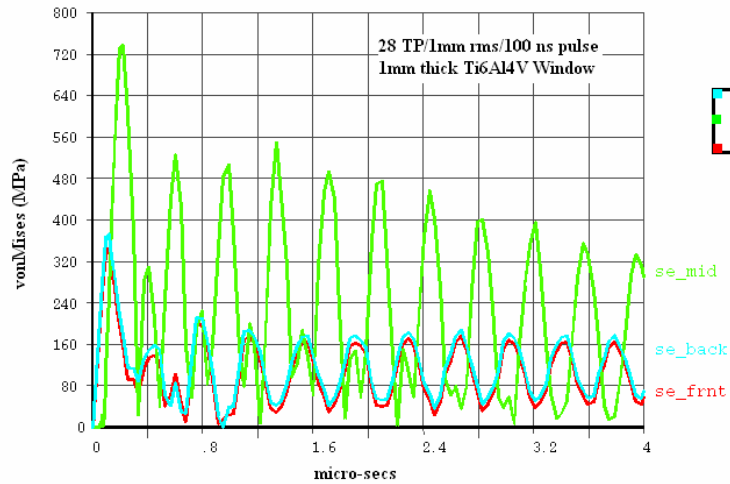

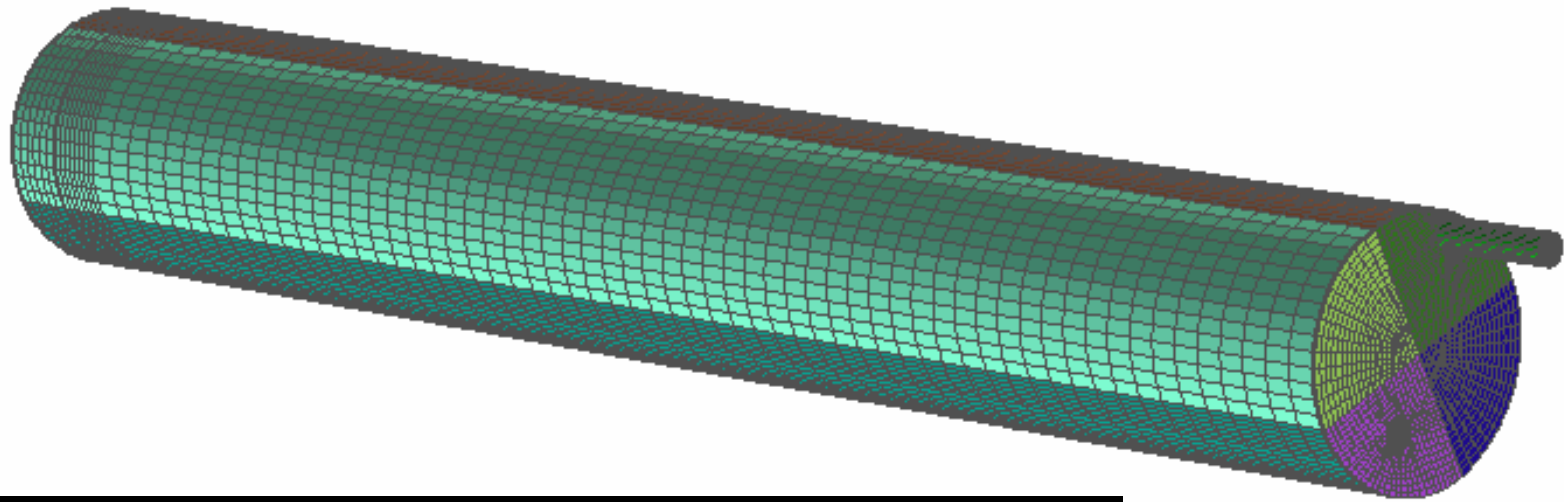

TESTING LS-DYNA TO RAPID PULSE HEATING

Time = 1.6858
Contours of Temperature
min=300, at node# 1
max=315.87, at node# 13013

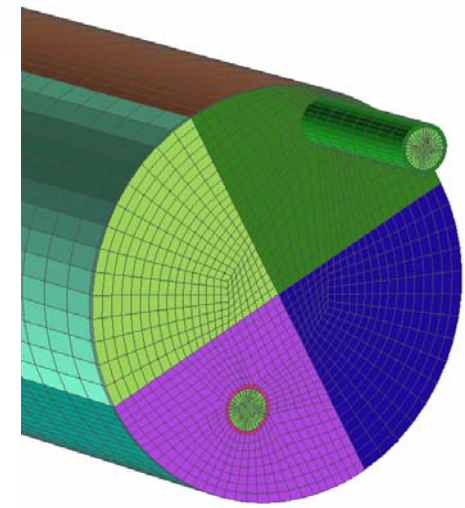
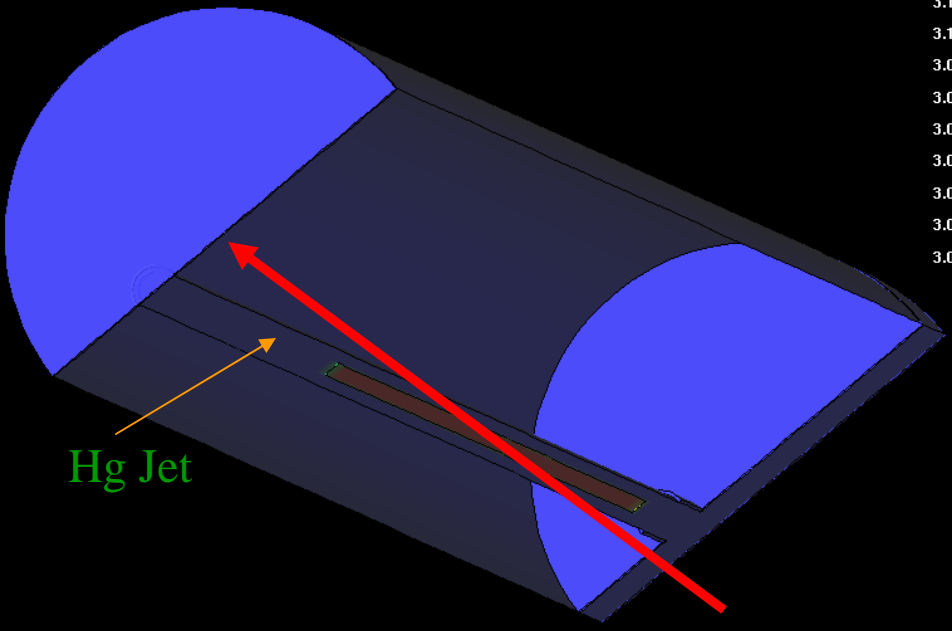
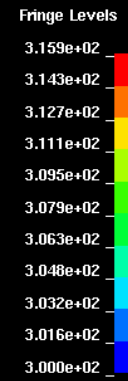

Hg pressure-induced effects on Jet Nozzle

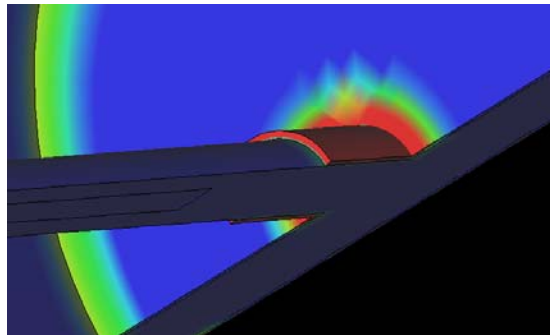
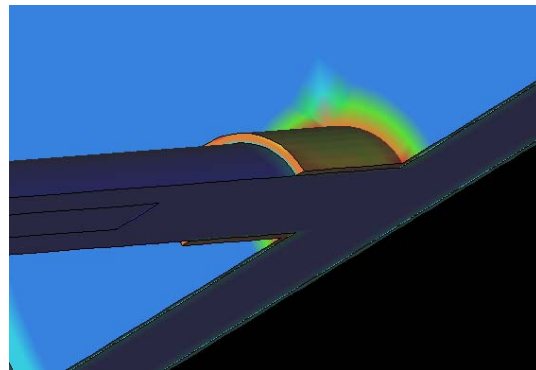
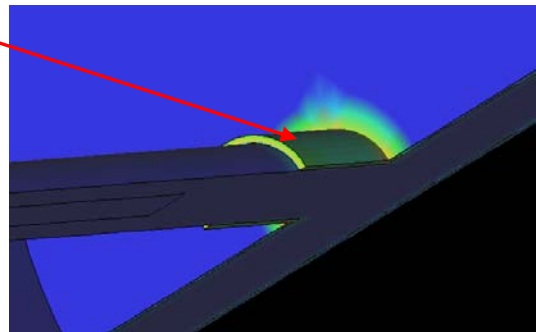
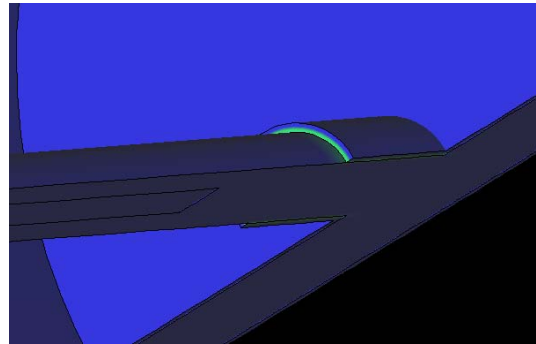
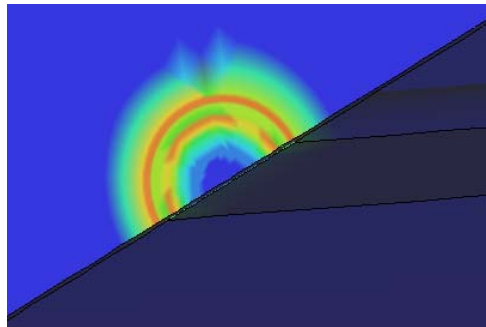
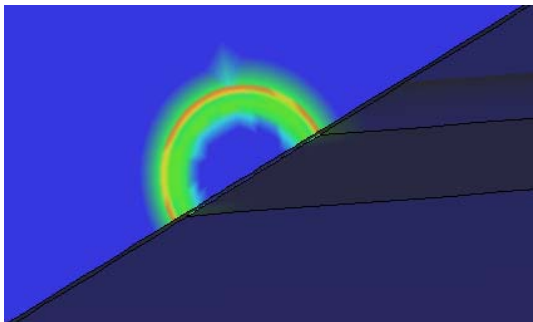
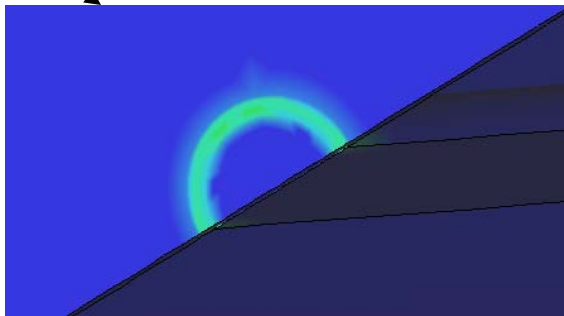
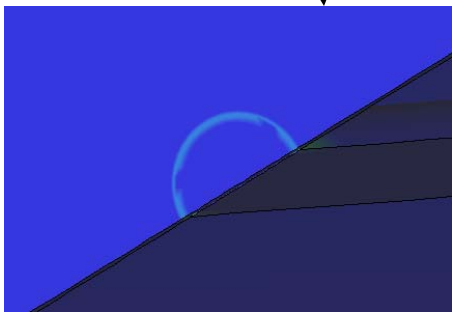
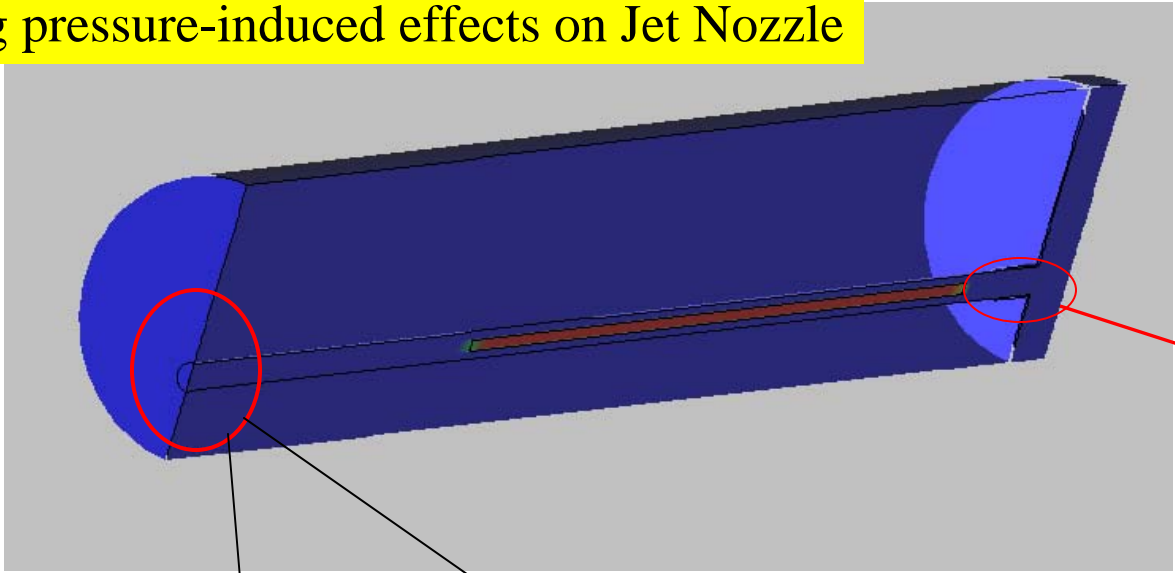

OTHER ON-GOING Studies:

(a) **Beam-induced Hg jet destruction**

LS-DYNA analysis with Eulerian-Lagrangian formulation to account for fluids and solids in the same analysis. Goal is to, hopefully, benchmark a simulation of the event with the test data. The benefit will be a clear understanding of how quickly the jet destructs that will in turn provide information as to how close the pulses in the real muon collider can be stacked

Preliminary Hg splash analysis induced by beam

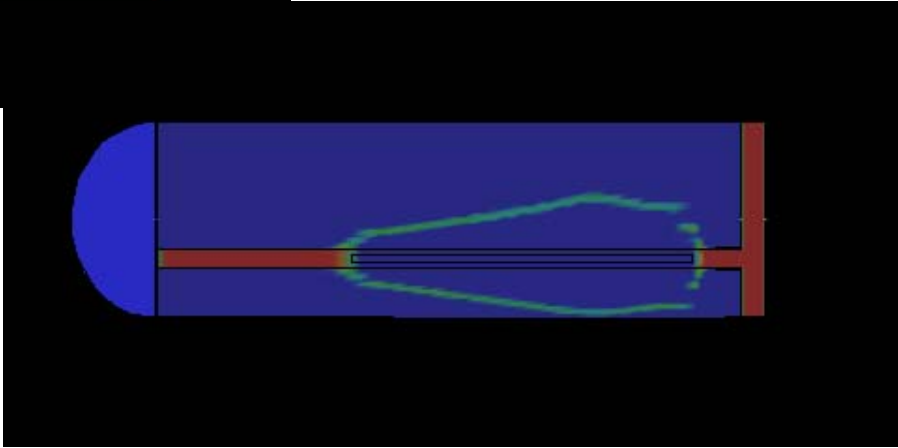
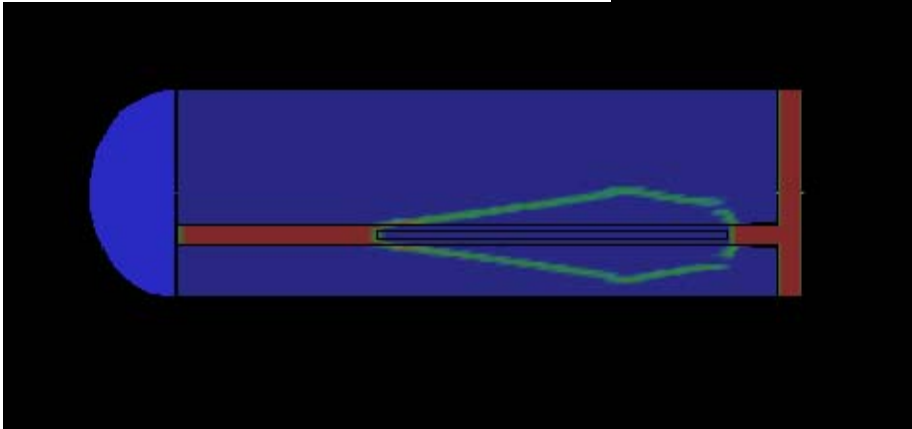
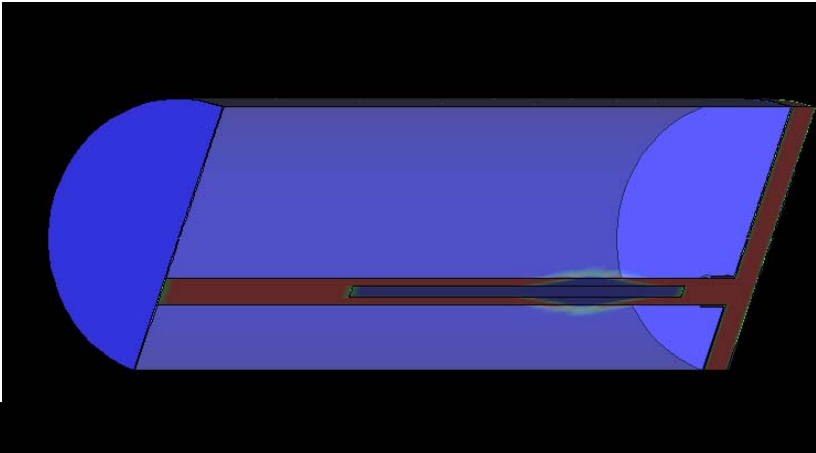
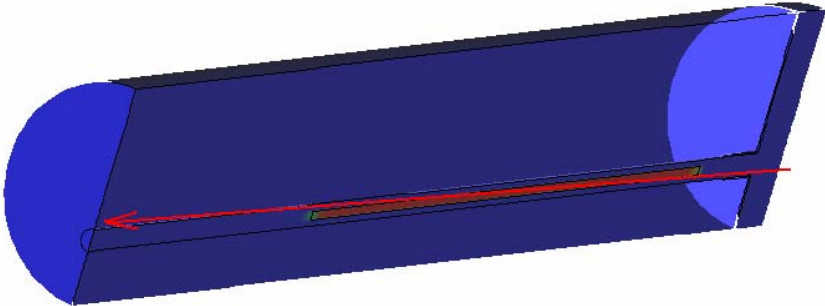

Preliminary Hg/beam interaction analysis – NO Field
Figure shows the zeroing of Hg density within the jet

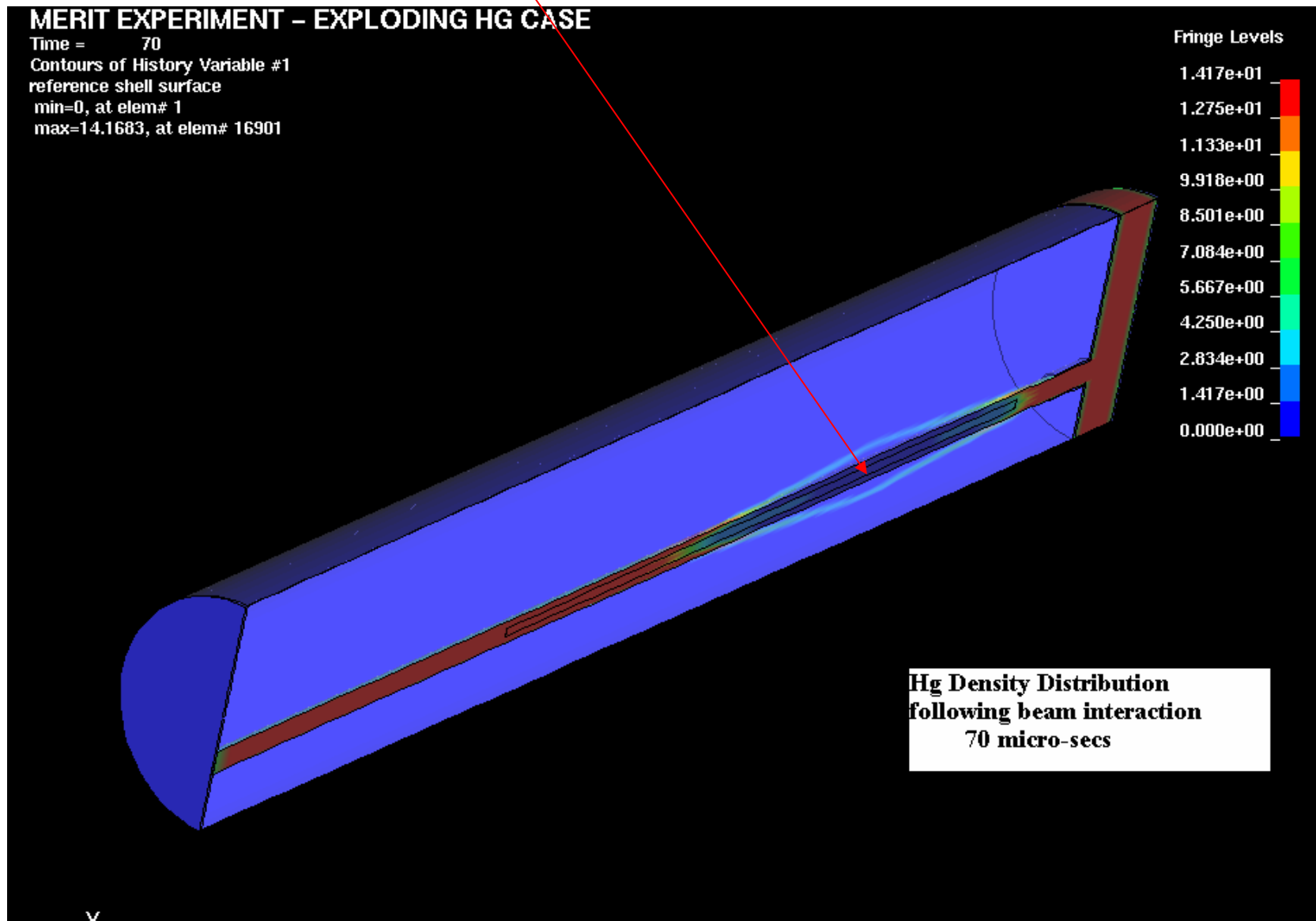

Snapshots of stresses in the outer vessel generated by splashed Hg

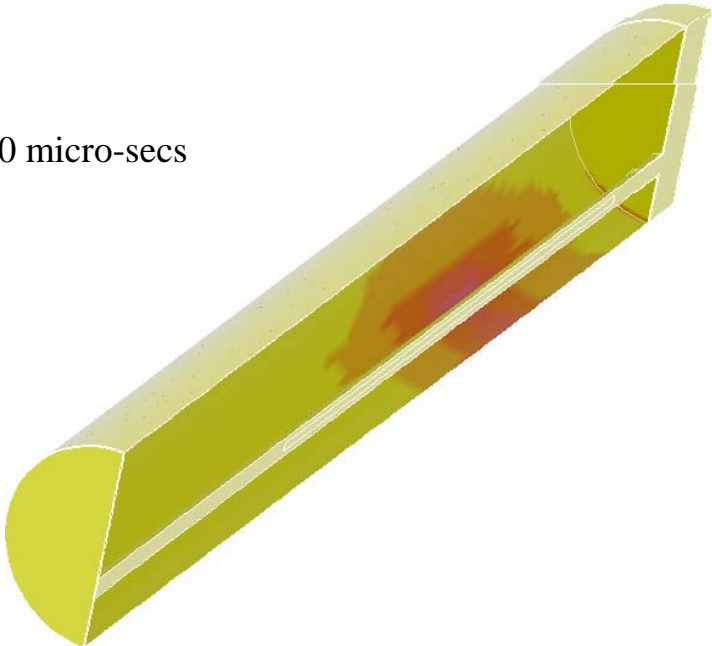
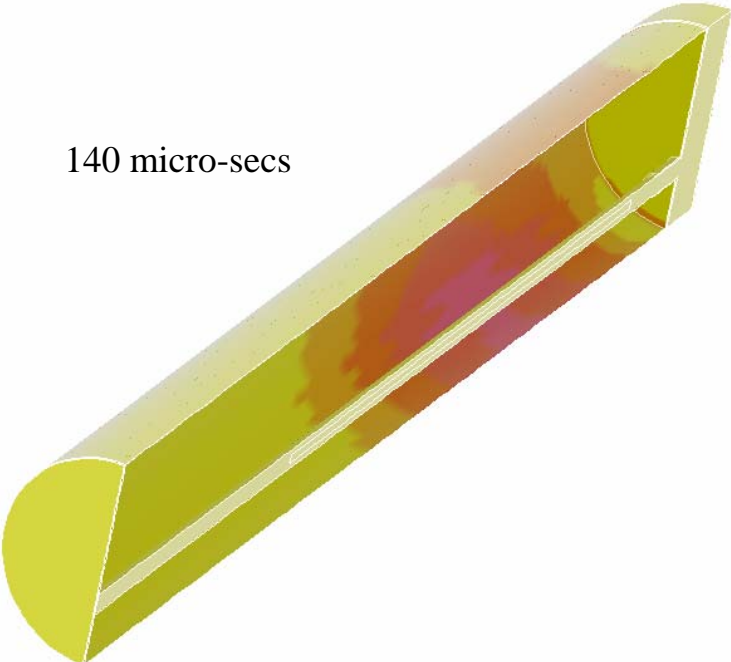
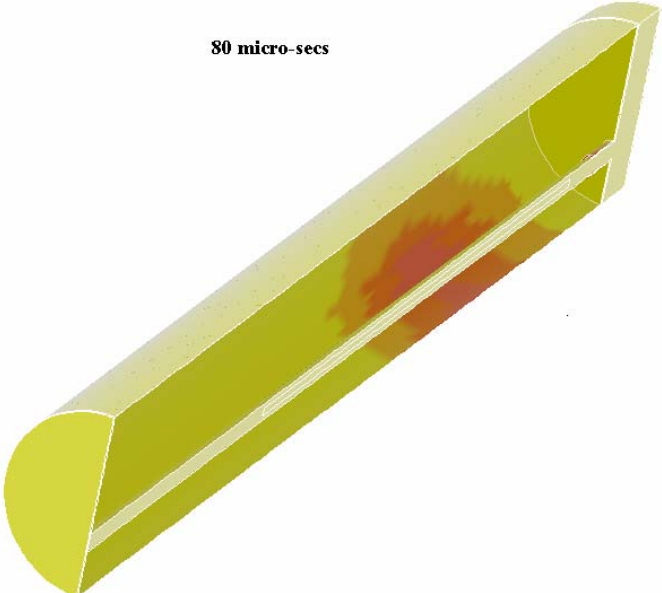
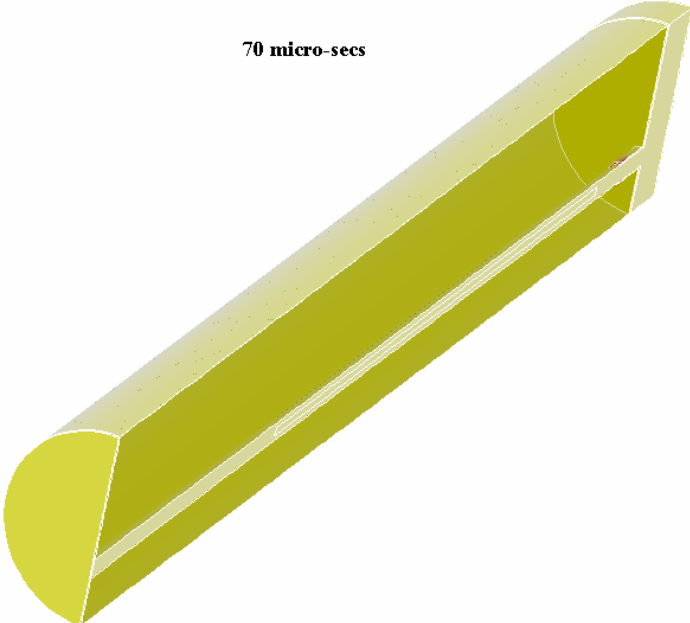

OTHER ON-GOING Studies:

Eddy currents and magnetic forces in the Hg volume just prior to jetting out into the target/beam interaction volume with 15 Tesla field present.

Based on ANSYS magneto-dynamic analysis looking to assess the forces the jet must overcome as it tries to come out of the nozzle

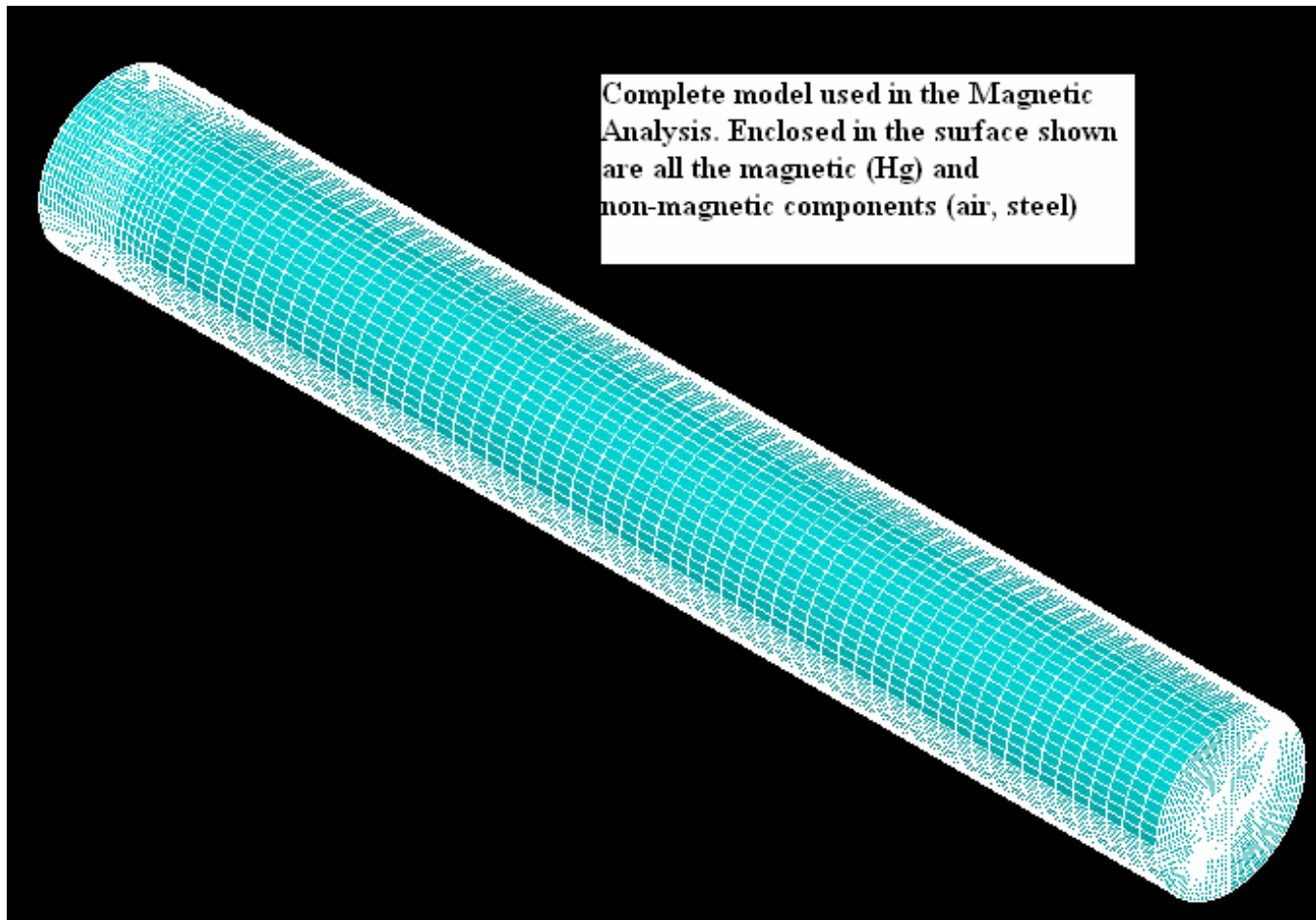

Conducting Volume (Hg) used in analysis. Air, steel and Ti not shown.
Uniform 15 Tesla magnetic field is imposed

