

4. Target System and Support Facility

4.1 Overview

The target facility extends from the pre-target primary beam focusing to the end of the decay channel. Technical components include the target, beam absorber, and solenoid magnetic field focusing system. While the ultimate goal is to target approximately 4 MW of proton beam in the target area, smaller values and different target materials (low Z etc.) are considered for the first phase of operation. Chosen initially is a carbon target with incident primary beam power of 1.5 MW. The target is embedded in a high field solenoid magnet of 20 Tesla, and followed by a matching section channel, where the field tapers down to 1.25 T. An iterative design process has been carried out in optimizing Monte Carlo code flux projections with realistic magnetic field parameters. The severe radiation environment and component shielding requirements strongly influence design choices.

The system design includes capture and decay channel solenoids. A cost design optimization for the 20 T capture solenoid is provided, balancing resistive and superconducting magnet contributions. Facility requirements, including shielding, remote handling, radioactive water system, etc. are based on the final design goal of 4 MW. Extent of the Target Support Facility and radiation handling equipment includes the 50 meter decay channel, where remote handling operations are also required, because of intense neutron fluxes.

4.2 MARS Simulation of Captured Meson Beam, Radiation in the Solenoid and the Shielding

4.2.1 Captured π / μ Beam vs Target and Beam Parameters

Realistic 3-D geometry, material and magnetic field distributions [1] based on solenoid magnet design optimization have been implemented into the MARS14(2000) Monte Carlo code [2]. Carbon and mercury tilted targets of various lengths and radii were studied. A variation in the 20 T solenoid region of B_z and B_r with z results in the reduction of the π/μ yield in the decay channel by about 7% for a long carbon target and by 10–14% for a short mercury target compared to the ideal case. Results of a detailed optimization of the π/μ yield vs. target material with the MARS14(2000) code are as follows.

For the given parameters the kinetic energy interval of $30 \text{ MeV} < E < 230 \text{ MeV}$ (around the spectrum maximum at $z \geq 9 \text{ m}$ from the target) has to be considered as the one to be captured by a phase rotation system. The yield grows with the proton energy E_p , but the yield per beam power is almost independent of E_p for high-Z targets at $6 < E_p < 24 \text{ GeV}$, and drops by 30% at 16 GeV from a 6-GeV peak for graphite (see Figure 1). The higher E_p reduces the number of protons on target, but results in more severe energy deposition in the target. The yield is higher by up to 30% for the target tilted by 50 to 150 mrad. A tilt angle of 50 mrad is chosen to locate the primary beam dump at $\sim 6 \text{ m}$ from the carbon target.

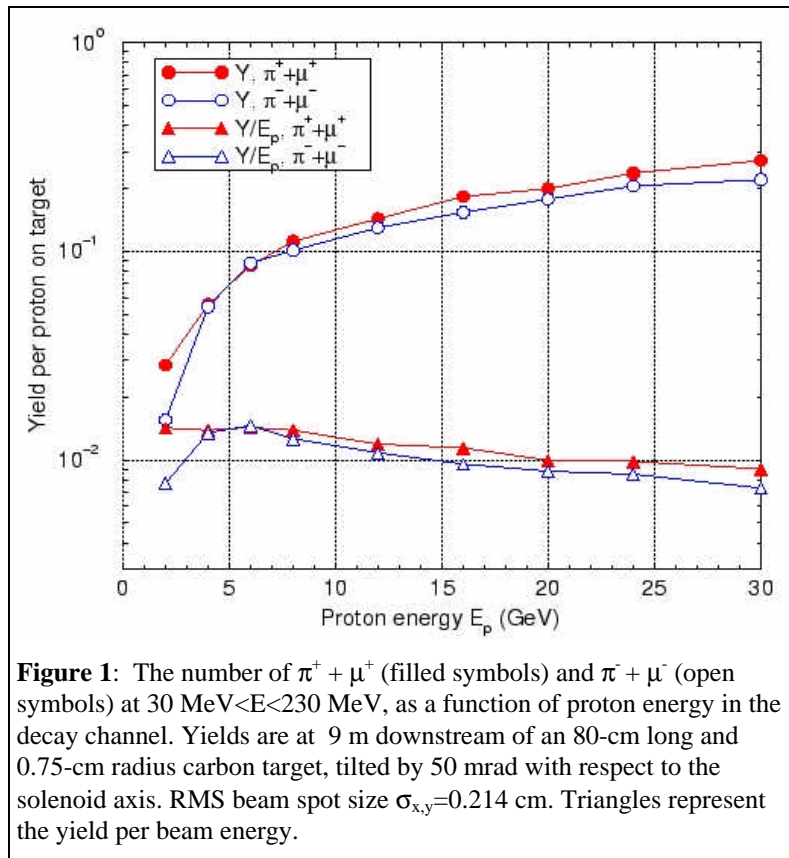

Figure 1: The number of $\pi^+ + \mu^+$ (filled symbols) and $\pi^- + \mu^-$ (open symbols) at $30 \text{ MeV} < E < 230 \text{ MeV}$, as a function of proton energy in the decay channel. Yields are at 9 m downstream of an 80-cm long and 0.75-cm radius carbon target, tilted by 50 mrad with respect to the solenoid axis. RMS beam spot size $\sigma_{x,y} = 0.214 \text{ cm}$. Triangles represent the yield per beam energy.

Maximum yield occurs at $R_{\text{target}} = 7.5$ mm for carbon and $R_{\text{target}} = 5$ mm for mercury targets with $R_{\text{target}} = 3.5\sigma_{x,y}$ and $R_{\text{target}} = 4\sigma_{x,y}$ conditions for the beam spot size, respectively. The often used criteria $R_{\text{target}} = 2.5\sigma_{x,y}$ reduces the yield by about 10% for the carbon target, but might be more optimal from the energy deposition point of view. Captured yield saturates at the target length of ~ 2 interaction lengths, i.e. 80 cm of graphite or 30 cm of mercury.

The ratio of mercury to carbon yields varies with the beam energy, as well as with other beam/target parameters. At 16 GeV it is in the range of 1.7 for positives and 2.2 for negatives. Optimizing beam/target parameters, it is found that the best results for the $(\pi+\mu)/p$ ratio at 16 GeV in the decay channel with the given cut are: $Y_{\pi^+\mu^+} = 0.182$ and $Y_{\pi^-\mu^-} = 0.153$ for the 80-cm carbon target and $Y_{\pi^+\mu^+} = 0.309$ and $Y_{\pi^-\mu^-} = 0.315$ for the 30-cm mercury target; i.e., at 16 GeV (best Hg)/(best C) = 1.7 (+) and 2.06 (-).

To provide 2×10^{20} muon decays per year in the straight section at 15 Hz, one needs to have 6×10^{12} muons per pulse in the decay channel. With that, needed are 3.30×10^{13} (and 3.92×10^{13}) protons per pulse at 16 GeV on optimal carbon target for positives (and negatives), respectively. This corresponds to 1.27 (1.51) MW beam. For a mercury target these numbers are 1.7 (2.06) times lower. Figure 2 shows the required number of protons and beam power as a function of the beam energy, for the carbon target. At 16 GeV, the peak instantaneous temperature rise is $60\text{-}70^\circ\text{C}$ and power dissipation is 34.3 (40.7) kW. For mercury targets the required beam power is lower, 0.72 MW; however, peak temperature rise per pulse is 750°C , because of higher energy deposition.

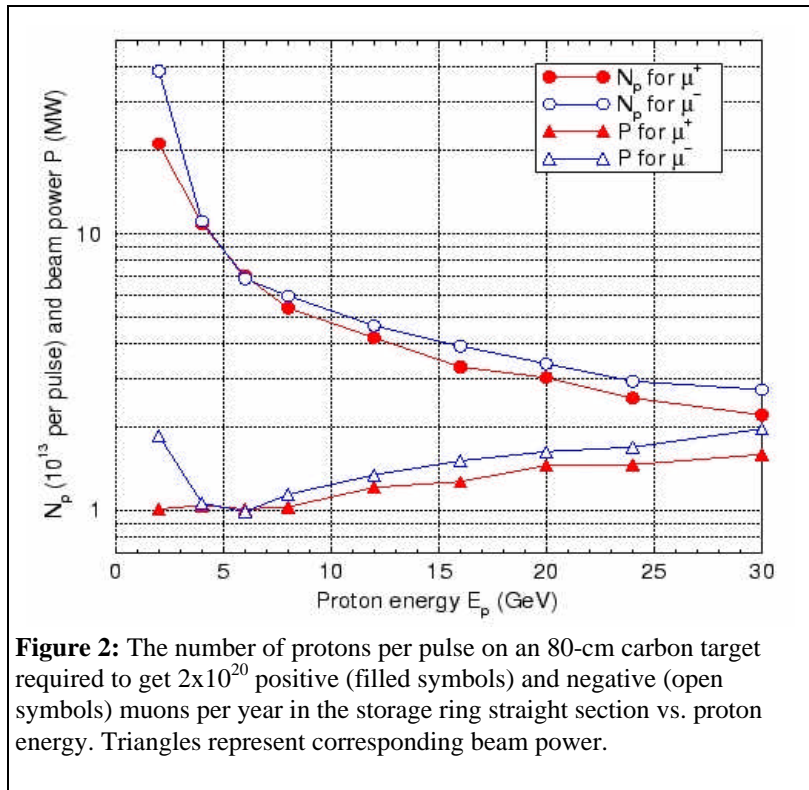

Figure 2: The number of protons per pulse on an 80-cm carbon target required to get 2×10^{20} positive (filled symbols) and negative (open symbols) muons per year in the storage ring straight section vs. proton energy. Triangles represent corresponding beam power.

Study of the final focus optics on target for the primary beam has shown that the optimal targeted beam size of $R_{\text{target}} = 3.5\sigma_{x,y}$ can be achieved on a 7.5mm radius target using conventional magnets.

Considered is a 16 GeV proton beam with a 60π mm-mrad normalized emittance (for a 1.5 MW beam), and $\Delta E/E = \pm 2\%$.

4.2.2 Radiation Load and Shielding

Full MARS14(2000) simulations have been performed to calculate the accumulated dose and particle flux in the target, and in the resistive and superconducting coils in the high-field, transition and low-field regions. These calculations enable determination of adequate tungsten-based shielding, the residual dose rates on the system components and ground water and personnel radiation shielding. Figure 3 shows the calculated radial distribution of particle flux ($\text{cm}^{-2}\text{yr}^{-1}$) and absorbed dose (Gy/yr) for a 1.5 MW 16 GeV beam on a carbon target. Similar distributions are calculated for the beam dump region, at about 6 m downstream of the target in the decay channel.

For a 1.5 MW beam, the annual hadron flux in a stationary graphite target is $5 \times 10^{21} \text{cm}^{-2}$, which corresponds to several months of target lifetime. The annual hadron flux ($E > 0.1$ MeV) and dose in the hottest spot of the inner resistive coil are $1.2 \times 10^{20} \text{cm}^{-2}$ and 3×10^{10} Gy, respectively. This corresponds to ~ 3 year lifetime limit for copper and ceramic. As discussed later, other considerations also severely limit the lifetime of the resistive coil. The annual neutron flux ($E > 0.1$ MeV) and the dose in the hottest spot of the high field superconducting coil are $8 \times 10^{17} \text{cm}^{-2}$ and 1.3×10^7 Gy, respectively, or 15 to 20 year lifetime. The annual neutron flux ($E > 0.1$ MeV) and dose in the hottest spot of the potted superconducting coil at the beam dump are $7.6 \times 10^{17} \text{cm}^{-2}$ and 4.1×10^7 Gy, respectively, or 7-10 year lifetime with the

current shielding. The lifetime numbers are rather uncertain, due to lack of data for radiation damage to superconducting materials at neutron energies above 14 MeV. With better understanding of these effects, a shielding design can be adapted that provides longer coil lifetime.

Residual dose rates for a 1.5 MW beam are up to 10^7 mSv/hr (10^6 R/hr) on the target, bore tube and inner resistive coil, 10^3 mSv/hr (100 R/hr) on the CICC (cable-in-conduit conductor) coil and 10^2 mSv/hr (10 R/hr) on the vessel, with the requirement for remote control and robotics. Radiation shielding requirements based on these rates are presented as part of the target support facility design.

4.3 Conceptual Design and Cost Estimate for the Capture and Decay-Channel Solenoids

4.3.1 Requirements

There are straightforward requirements for capture and decay-channel magnet systems but these must be achieved in a difficult radiation environment. The radiation is intense, requiring that the magnet systems incorporate a significant quantity of shielding, especially in the immediate vicinity of the target and the beam absorber.

A field of 20 T is required on-axis in the target region, which should be uniform to within $\pm 5\%$ over the length of the target (800-mm). The beam and target are inclined relative to the magnetic axis, requiring a clear bore in the capture solenoid (with integral shield) of 150-mm diameter for access. From the target region, the field should drop smoothly over the next 2 m to 1.25 T, which is then held constant over the next 48 m. A simplified representation of the required field profile is shown in Figure 4. It was found that if a realistic profile matches the ideal field to within $\pm 5\%$ (also shown in Figure 4) it is satisfactory for achieving the desired beam flux. The required system lifetime is 20 years.

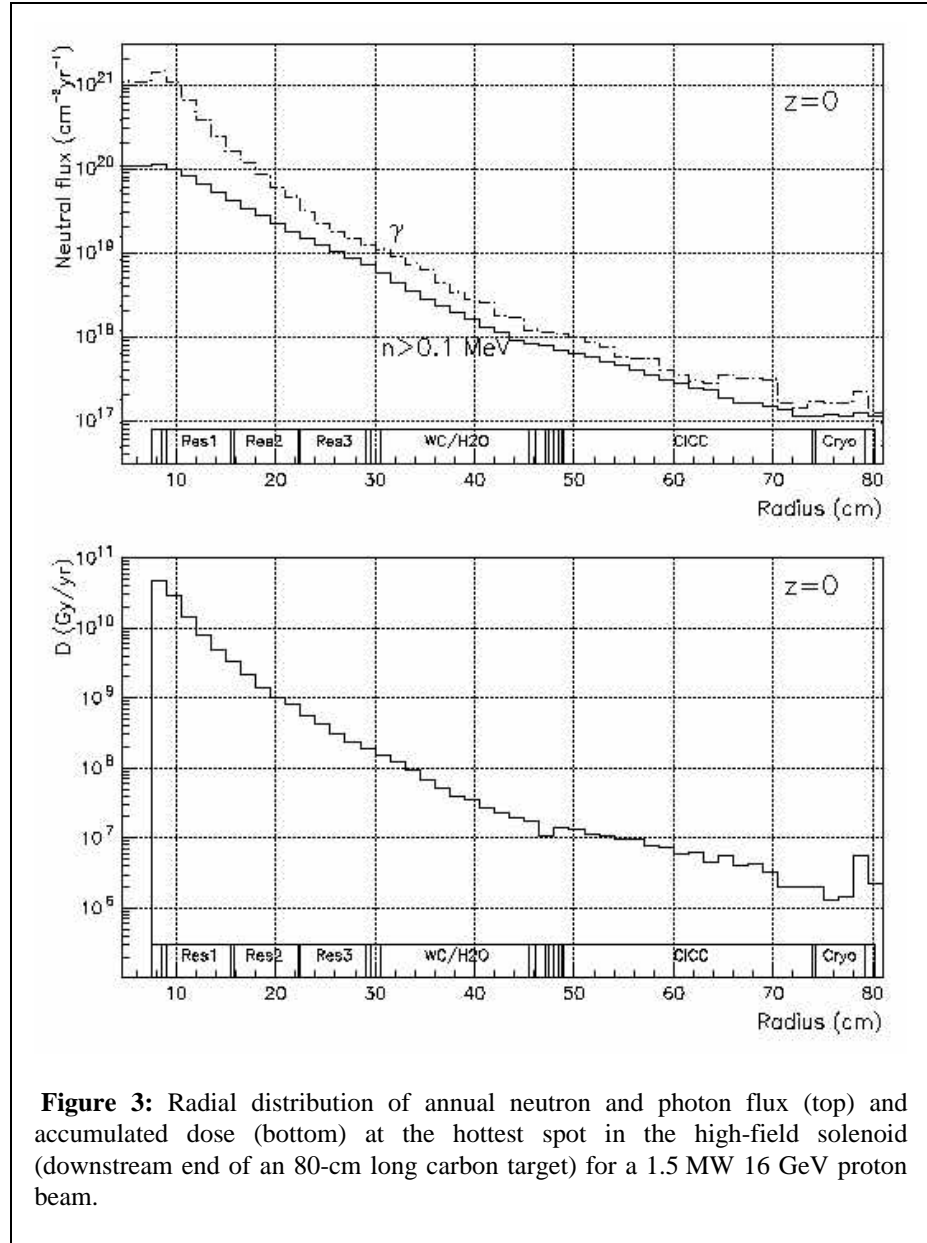

Figure 3: Radial distribution of annual neutron and photon flux (top) and accumulated dose (bottom) at the hottest spot in the high-field solenoid (downstream end of an 80-cm long carbon target) for a 1.5 MW 16 GeV proton beam.

4.3.2 Approach

Achieving the desired field profile requires the specification of coil geometries using feasible coil-pack current densities, which in turn requires that certain engineering constraints be satisfied. The operative engineering constraints depend upon the particular magnet technologies employed in the design, and settling on design details involves an assessment of relative costs. Therefore, the basic approach has been to:

- review the potentially applicable magnet technologies,
- establish the appropriate engineering constraints,
- perform a benchmark design wherein operating conditions are clarified, and establish critical design criteria,
- construct appropriate cost algorithms, and
- use these to optimize the system design.

During the limited time available for this study, three design iteration cycles have been made.

In the target region where 20 T on-axis field is required, this is achieved with a resistive magnet close to the bore, a water-cooled shield outside of this, and an outside superconducting magnet. The principles underlying this choice are:

- The resistive coil pack can be made with reasonable radiation tolerance.
- The resistive magnet will be more cost effective closer to the bore.
- In that position it can also provide some nuclear shielding to the superconducting coil.
- The resistive magnet has a finite life in any case caused by cavitation due to forced water flow.
- To minimize costs, it is expected that a superconducting magnet on the outside would provide a field as high as 10 T.
- To ensure that the superconducting magnet will survive approximately 20 years, a minimum amount of shielding must be provided which includes the resistive magnet plus other material.

4.3.3 Resistive-Magnet Technologies

The technology options considered for the resistive magnet are hollow-conductor, poly-helix, and poly-Bitter (other options, typically those invoked for more specialized or challenging applications than we have here, were not pursued). Hollow-conductor technology offers simple construction and long life but is severely limited in attainable current density because of inherently long cooling passages. High current densities are attainable with poly-helix technology, but this technology is less well developed and, in particular, the insulation is subjected to complex stresses, making it even more problematic in a radiation environment. We have chosen to design with poly-Bitter technology, which is highly developed, capable of very high current densities, and subjects the insulation to predominantly compressive stress. However, the life-time of poly-Bitter magnets is limited (in designs appropriate for the present application, primarily by water erosion of insulating materials and degradation of electrical contacts).

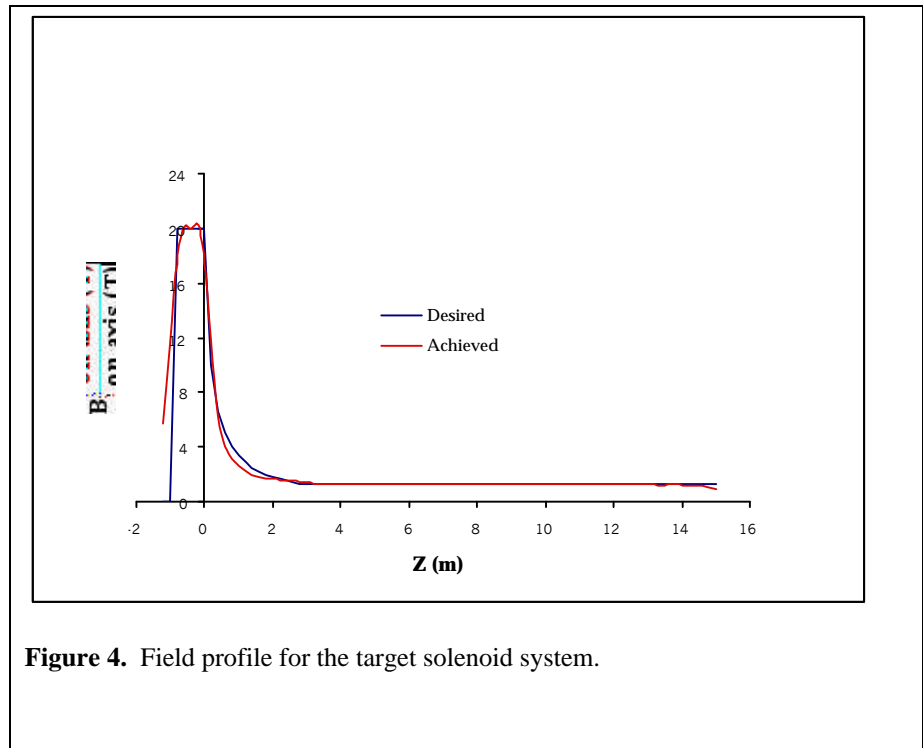

Figure 4. Field profile for the target solenoid system.

4.3.4 Shield Technologies

For the shield, the concept is a toroidal cannister with stainless steel walls filling the annular space between the resistive insert and the superconducting outsert magnet. The cannister will be filled with tungsten-carbide (WC) balls (approximately 80% filling factor). Cooling will be achieved by circulating water through the interstices of the packed bed of WC balls.

4.3.5 Superconducting Magnet Technologies

Operating the superconducting magnet near the damage limit of the insulation and the superconductor results in an appreciable heat load in the windings, significantly higher than what can be accommodated without direct cooling. Two well-developed options for cooling are bath cooling with ventilated windings and forced-flow cooling using cable-in-conduit conductors (CICC).

Bath cooling is a simple and passive technology wherein the windings remain nearly isothermal at the saturation temperature. However, the potential for vapor locking the channels within the windings, especially in coils with appreciable thickness, may be a concern.

A design with forced-flow cooling using CICC technology was chosen. It is somewhat more complex and requires a finite temperature margin, but using an active cooling approach is generally capable of much higher and more predictable heat removal. For most applications, a design using CICC technology is limited by radiation damage rather than by heat removal. Since the windings are not isothermal at the bath temperature, this approach benefits from the use of a superconductor with higher critical temperature (T_C) such as Nb_3Sn , which is also the choice here.

4.3.6 Engineering Constraints

The National High Magnetic Field Laboratory (NHMFL) [3] has been very successful in applying the combination of poly-Bitter technology for resistive magnets and CICC technology for superconducting magnets. The recently completed 45 T Hybrid uses both. The resistive insert of this magnet is designed to contribute 31 T and the superconducting outsert, 14 T. Except for the radiation environment, the requirements of the capture solenoid are relatively less demanding. The NHMFL experience on the 45 T Hybrid Magnet provides a good feel for the critical engineering constraints for the resistive and superconducting technologies that were chosen here.

4.3.7 Resistive Magnet

For poly-Bitter technology applied to the capture solenoid the critical constraints are:

- Heating $< 5 \text{ W/mm}^3$
- Hoop stress $< 300 \text{ MPa}$
- Lifetime 4000 h
- Radiation damage (no limit has been set but should be less limiting than the normal lifetime of 4000 h)

4.3.8 Superconducting Magnet

For the superconducting solenoid, the critical constraints are:

- Membrane stress in the conduit (von Mises) $< 800 \text{ MPa}$
- Hoop strain $< 0.3\%$
- Temperature margin $> 0.5 \text{ K}$ at any point in the coil in the presence of heating
- Hot-spot temperature during a quench $< 150 \text{ K}$, assuming the quench is detected within 1 s and the coil is discharged with a time constant of 5 s
- Absorbed dose $< 10^8 \text{ Gy}$ to preclude radiation damage to the insulation

4.3.9 Benchmark Design

Many of the operating conditions for the magnets could not be assessed without first establishing a benchmark design, with specifications not greatly different than a fully qualified or a fully optimized design. The benchmark design was established simply by using educated guesses for achievable current densities, coil-pack compositions, and appropriate field contributions of the resistive and superconducting magnets. The benchmark design was then used as a vehicle for establishing such critical conditions as intercoil forces, radiation-flux/heating profiles, radiation fluence/dose, etc. as

well as a basis for constructing simple analytic expressions for these, which could then be used in the design optimization process. In addition, the benchmark design provided a degree of visualization that permitted the establishment of critical assembly tolerances and gaps, the placement of structural components, etc., all of which were important design constraints and which significantly impact the design process.

4.3.10 Cost Algorithms and Design Optimization

The heart of the design process are the estimates and scalings of system costs. Given that the system is feasible, this is the most important issue. Cost algorithms were constructed that are applicable to a wide range of magnet system configurations. The underlying principle is the decomposition of the system into components, materials, processes, or services for which there is a reasonable experience base of cost. From that experience base, a judgement is made of the most appropriate scaling parameter (mass, length, volume, etc.) for each. The cost of a system is then just the sum of these. The optimum design is the one that satisfies all the physics requirements and meets all the engineering constraints for the least overall cost. Establishing that design is then a straightforward exercise in non-linear optimization of a function of many variables with both equality and inequality constraints on the variables.

4.3.11 System Description

The capture solenoid is a complex system with a number of design parameters that can be varied to minimize the total cost. In comparison, the coils for the decay channel and transition region are far less challenging. These coils will be constructed with epoxy-impregnated windings of Cu/NbTi composite wire and conduction cooled. Although their design feasibility will not be an issue, the length of the channel results in a total cost that is not insignificant. On the other hand, these coils are essentially identical and can be built with relatively mature, commercial technology. Therefore, little variation is anticipated in the projected cost, which is estimated to be approximately 256 k\$ for the transition coil (including cryostat) and approximately 175 k\$/m for the coils in the decay channel (including cryostat). Results of the cost optimization for the capture solenoid are displayed in Table 1. The system description is essentially the same whether the optimization is based on capital cost or capital plus 20-year operating cost.

Although the optimization resulted in a significantly larger resistive magnet, the resulting optimal value for the build is less than the constrained value. The balance between resistive and superconducting magnet contributions depends heavily on the rate of energy deposition in the latter. For the “Optimized” case, the Bitter coil contributes 11 T and the superconducting coil contributes 9 T.

		Base	Optimized
Key Parameters/Variables:	Current [kA]:	10	10
	Build of sc magnet [m]:	0.250	0.231
	Build of outer res. magnet [m]:	0.065	0.088
	Estimated heat load on sc [W]:	903	312
Resistive System	Total Capital costs (k\$):	7,266	7,708
	Operating/maintenance costs (k\$):	45,843	49,164
Shield	Total capital costs (k\$):	735	639
	Operating/maintenance costs (k\$):	1.4	0.5
Superconducting System	Total capital costs (k\$):	8,039	5,686
	Total operating/maintenance costs (k\$):	20,980	9,700
Ensemble:	Total costs (k\$):	82,864	72,899
	Capital cost (k\$):	16,039	14,034
Low-Field System	Capital costs (k\$):	8,331	8,331

Table 1. Results of system optimization compared to the base case. Virtually no differences were found between cost optimizations performed on capital cost and on total system cost; hence only the capital-cost optimized results are shown. The “Ensemble” cost refers to the 20 T capture solenoids and does not include the low-field coils.

4.4 Target Support Facility

The Target Support Facility for the neutrino source consists of the target region, crane hall, hot cell, and radiation handling equipment. It comprises a structure that is 8.4 meters wide by 80 meters in length and is located over the

proton beam window (PBW) region, the target region, and the decay channel. The 16 GeV proton beam-target interaction produces significant levels of neutrons and neutron-induced gamma activation; therefore, the facility requires significant shielding, provisions for remote handling equipment, and a hot cell. The radiation handling equipment that is used to replace the target and remotely handle life-limited components is arranged to have minimal impact on the facility design. A linear crane hall provides lift coverage to the areas over the target region, the decay channel, and the hot cell. There is ample laydown space for storing shield blocks that are removed to gain access to components in the target region and the decay channel. A 40-ton bridge crane and a bridge-mounted manipulator operate along the full length of the crane hall. Figure 5 is a cutaway view of the overall facility.

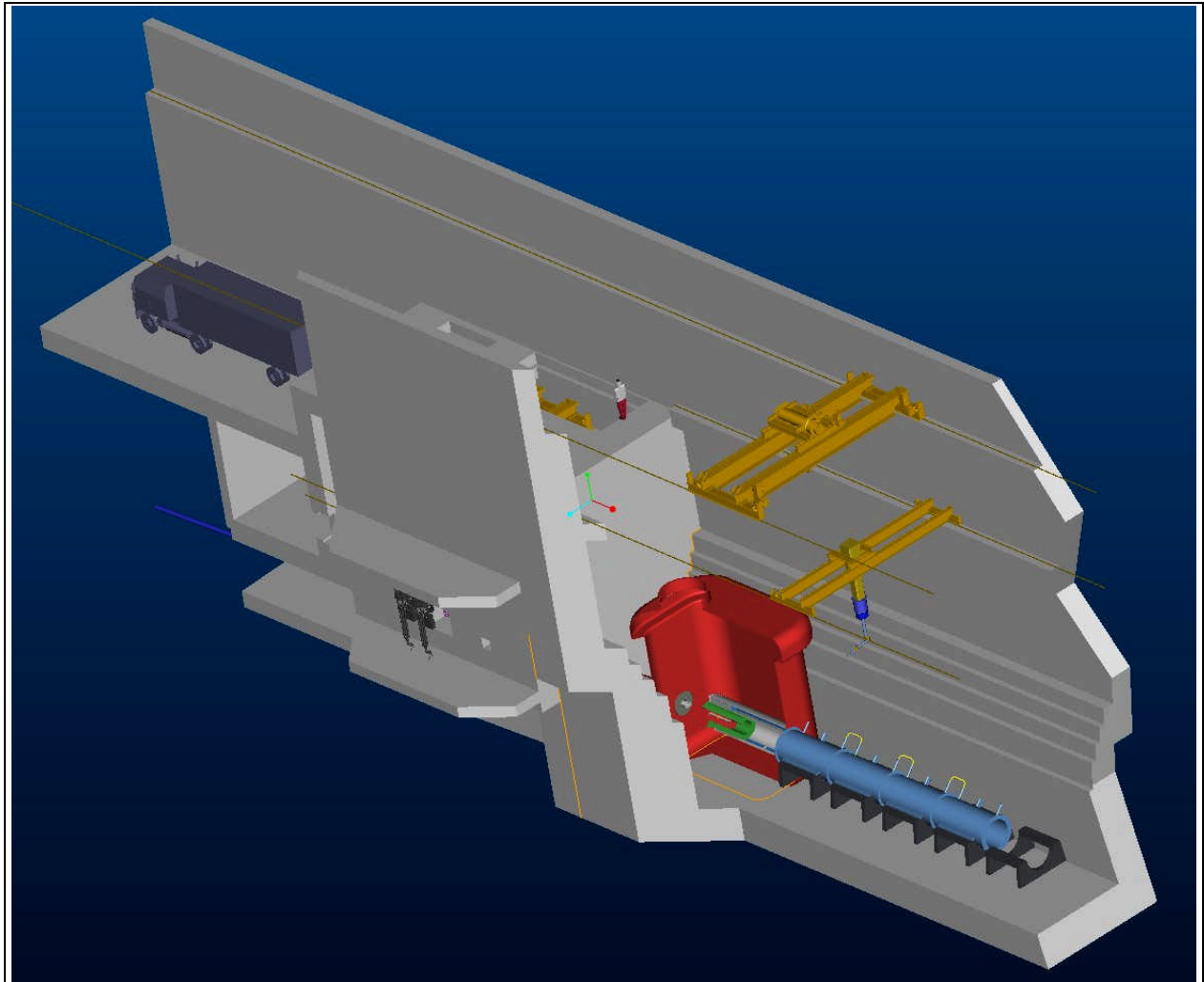

Figure 5. Overview of the Target Support Facility.

4.4.1 Design Requirements and Assumptions

The shielding for the target area is designed for a 16 GeV, 4 MW proton beam, although initial operations will be at 1.5 MW. The Neutrino Source Facility should have an operating availability of 2×10^7 s/y for all systems; therefore, annual downtime for scheduled and unscheduled maintenance activities, including those of the Target System, is 133 days per calendar year.

The major components in the Target Support Facility consist of components that are expected to survive for the life of the facility, i.e. >20 years, and life-limited components that require periodic replacement. Table 2 lists the expected component lifetimes based primarily on radiation damage criteria and a preliminary allocation of downtime for their replacement. The life-limited components greatly influenced design of the Target Support Facility. The design also utilizes the extensive Oak Ridge National Laboratory (ORNL) experience with high beam power target facilities[4].

Component	Expected Lifetime	Replacement Time
Target	3 mos	6 days
Target + Bitter Coil	6 mos	7 days
Target + Bitter Coil + PBW	1 yr	8 days
PB Instrumentation	1 yr	5-7 days
Beam Dump	5 yrs	1.5 mos
High Field S/C Coils	>20 yrs	9-12 mos
Low Field S/C Coils	>20 yrs	9-12 mos

Table 2. Component Lifetimes for the Target Support Facility

4.4.2 Target Region

The target region is the focus of remote handling activities that occur every three months. It consists of a helium-atmosphere vessel that contains steel shielding, a passively cooled graphite target module, a high field solenoid magnet assembly and the proton beam window. The vessel is approximately 4 x 6 x 7 meters with a removable lid. The smaller 2 meter diameter port on the lid is removed for routine replacement of the components listed in Table 2. The large lid can be removed if a superconducting coil in the first cryostat module ever needs replacing. The magnet assembly consists of a demountable resistive solenoid (Bitter coil) that is replaced every 6 months, a lifetime tungsten/steel shield, and a lifetime superconducting solenoid. These components are contained in a helium atmosphere. The He atmosphere prevents air-activation when the proton beam is on and minimizes evaporation of the graphite target.

The target is a graphite rod 1.5 cm diameter x 80 cm long, held in place by two spoke-like graphite supports, in a 15 cm diameter stainless steel support tube. The target is radiatively-cooled to the water-cooled surface of the support tube. The axis of the target is parallel to the proton beam line but is oriented at 50 milliradians relative to the axis of the support tube. The support tube is aligned with the magnetic axis of the solenoid coils and is mounted into the bore of the Bitter coil. (Therefore, the overall axis of the target support facility has a 50 milliradian offset to the proton beam tunnel, in the horizontal plane.) Figure 6 is a cutaway view of the target module mounted in the solenoid coil structure.

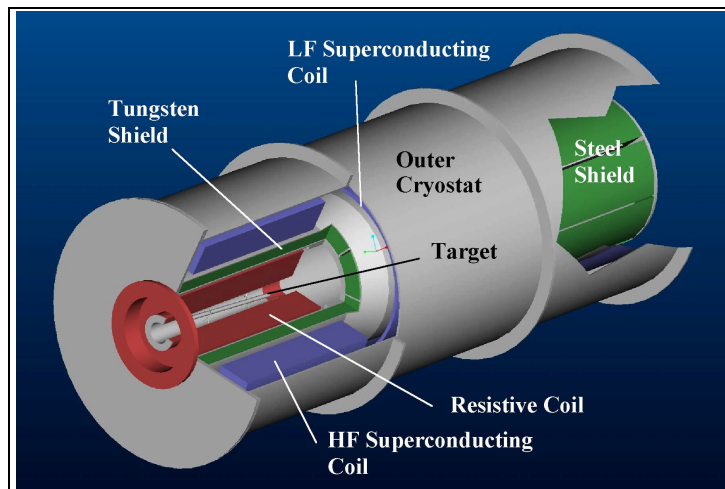

Figure 6. Cutaway view of the high-field solenoid, target, and shielding in the cryostat module.

Preliminary analysis of the target indicates that radiative cooling and low thermal stresses are achievable for a beam power on target of up to 1.5 MW. For a uniform heating distribution throughout the target, internal thermal stresses were determined to be 1/5 the strength of graphite. Most probably, radiation damage will limit the target lifetime. A damage criterion of 5 displacements per atom (dpa) was chosen to be a reasonable limit; this equates to approximately 3 calendar months before the target must be replaced. (Sublimation of the target is not an issue since it operates at a temperature of about 1850⁰ C and is in a He environment.) Additional analysis is required to better understand an important remaining issue, shock wave effects from the 3 ns duration beam spill.

The Bitter solenoid is mounted within the bore of a tungsten radiation shield. The shield limits neutron heating to the high field superconducting coil (HFSC), protects the coil from radiation damage, and because of its high density, minimizes the diameter of this costly superconducting magnet. The shield is a stainless steel structure filled with water-cooled tungsten-carbide balls under the HFSC, but contains steel balls under the other three coils. The HFSC and the

first three low field coils are assembled in a common cryostat located within the He vessel. Figure 6 shows the arrangement of the coils and shielding. Use of a common cryostat was employed so that the coil-to-coil axial magnetic forces could be reacted within the cryostat, thereby avoiding external structure with its inherent thermal leaks to the coils.

The target is surrounded by steel shield blocks, which limit the prompt radiation effects to the surrounding area. Two meters of steel are required on the sides and bottom of the target module to meet the requirement for ground water protection, and approximately 4.5 meters of steel and 0.5 meter of concrete are needed above the target to limit the dose rate at the crane hall floor to 0.25 mr/h.

4.4.3 Decay Channel

The 50-meter long decay channel is a tunnel-like structure below the crane hall, located under approximately 5 meters of removable shield slabs. Figure 7 shows a cross section of the decay channel. The shield slabs are removable to gain access to the 12 cryostat modules that each contain 4 low field superconducting coils (LFSC). Under normal operations the decay channel does not require access since the LFSC are lifetime components. Each of the cryostat modules are mechanically joined together so that the inner cryostat surface makes up the vacuum boundary of the muon decay channel, but the outer cryostat surface is in an air atmosphere. The LFSC cryostat modules are similar to that shown in Figure 6.

The low field solenoids are protected from nuclear heating and radiation damage by a 30 cm thick, water cooled stainless steel shield. The first low field cryostat in the decay channel also contains a beam dump at $5.5 < Z < 6.5$ meters to absorb the portion of proton beam that passes through the target. In this region, the LFSC may require a diameter larger than the adjacent coils to accommodate the thickness of the beam absorber module, coolant lines and a suitable nuclear shield thickness. Downstream of the beam dump at the end of the first low field cryostat, a 60 cm diameter titanium window is in place to separate the helium atmosphere from the vacuum in the remainder of the decay channel. The shield requirements in the decay channel are virtually the same as those in the vicinity of the target because of the large diameter of the muon channel. Access into the decay channel requires lifting shield slabs weighing up to 40 tons and storing them in the crane hall.

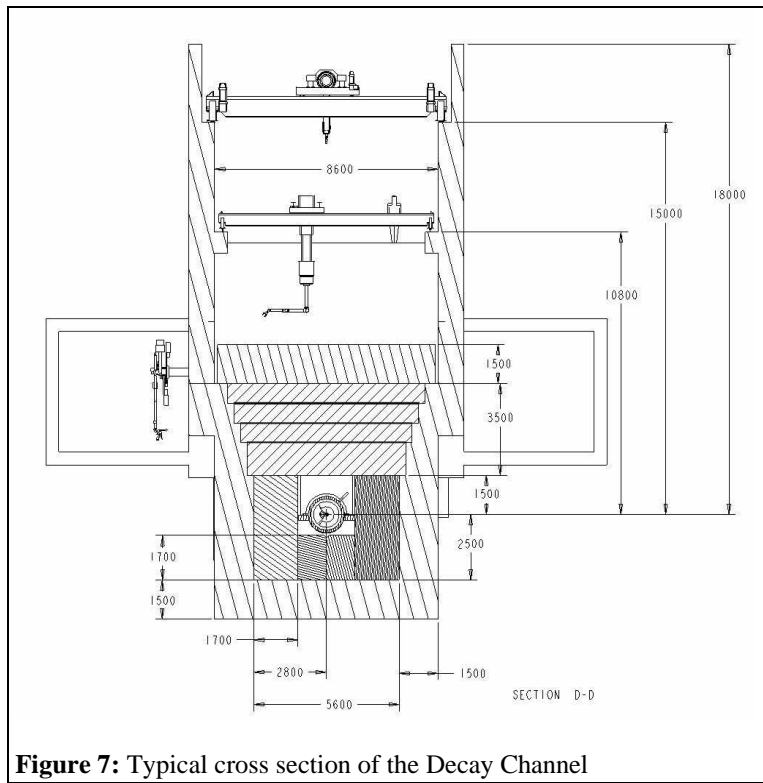

Figure 7: Typical cross section of the Decay Channel

4.4.4 Crane Hall and Hot Cell

The crane hall is located over the entire target support facility. It is 12 meters above the floor level, 80 meters long and contains a 40-ton overhead crane and a bridge-mounted manipulator system. The floor of the hall consists of removable shield slabs that provide access into the target region and the decay channel.

The hot cell contains a 20-ton bridge crane, overhead manipulator, through-the-wall manipulator, shield window, and CCTV and lighting. There are provisions to add up to three additional wall manipulators and windows. The hot cell size is determined by the floor space needed for the routine replacements shown in Table 2 plus handling a 4 meter long cryostat for the possible replacement of a solenoid coil. The operations in the cell are primarily handling the rad waste created by periodic replacement of the target, Bitter magnet, and proton beam window. These life-limited components are not repairable due to the nature of their radiation damage and are temporarily stored in the hot cell prior to disposal. They are brought into the hot cell with the 40-ton crane by removing any of the three roof plugs. The hot cell floor

contains shielded storage areas for up to 4 targets, 2 Bitter coils, and 1 proton beam window. The hot cell is partially located over the proton beam tunnel and has floor plugs that provide access to the proton beam focusing magnets/instrument module. Remote replacement of the instrumentation on this module is done in the hot cell annually.

4.4.5 Remote Handling

Remote handling operations are required on all of the components located in the target region and the decay channel. However, when the crane hall floor shielding is in place, unlimited personnel access is permitted in the crane hall even with the beam on. This is the most cost-effective way to design the shield since meeting site-boundary radiation criteria are efficiently met by placing shield material as close to the source of radiation as possible.

4.4.6 Equipment

The equipment for lifting and remotely handling components listed in Table 3 is determined by their weight and size. For example, the crane capacity is established by the high field cryostat module, which is the heaviest component that could require handling during the facility lifetime. Table 3 is a listing of the size and weight of the key components.

The bridge-mounted manipulators located in the crane hall and hot cell are commercially available, single arm, dexterous, force reflecting systems. They are used in conjunction with special fixtures for lifting and handling the target module, Bitter coil, PBW, etc. These manipulators are operated from control stations located in the hot cell gallery and their operations require remote viewing. The through-the-wall manipulator in the hot cell is used in conjunction with a shielded viewing window for operations that can be done at a work station.

4.4.7 Operations

The maintenance philosophy for dealing with the life-limited components is to replace them at scheduled intervals with new modular components. Since they are not repairable, they will be handled as rad waste. Therefore, the need for special purpose tools and handling fixtures is minimal. Furthermore, almost all of the components that require periodic replacement are located in the target region; hence, many of the remote handling tasks are common. As a result, a preliminary estimate of downtime to replace life-limited components (Table 2) was found to be within a reasonable allocation of time for scheduled maintenance activities.

Component	Weight (lbs)	Size (m)
HF Cryostat	72,500	1.5 dia x 4.2
HF S/C Coil	18,000	1.5 dia x 1.2
Tungsten Shield Module	44,000	1.0 dia x 4.0
LF Cryostat/Steel Shield	44,000	1.3 dia x 4.0
Steel Shield Slabs	72,000	0.4 x 1.0 x 3.0
Vert. Steel Shield Blocks	28,000	0.6 x 1.2 x 2.0

Table 3. Component Weights and Sizes

The typical tasks for replacing the target, Bitter coil, and PBW are as follows:

- remove the stacked shielding above the He vessel (crane and personnel)
- remove the 2-meter port cover (crane and personnel)
- decouple water connectors for each steel shield block and remove the blocks that surround the target (this task and the remainder are remote)
- decouple instrument and water line connectors to the target, unbolt the target module, disengage and remove with the bridge manipulator
- decouple instrument connectors and water lines to the Bitter magnet, unbolt from the tungsten shield flange, engage a crane-mounted handling fixture for removal
- decouple instrument connectors and water lines to the PBW, disengage the commercial remote-connector with manipulator tools, remove with the bridge manipulator and holding fixture
- replacement of these components follows the reverse order.

4.5 Summary

Current design status of the target system and support facility provides a system plan for targeting a 1.5 MW beam, and providing a solenoid magnetic field focusing system which meets rigorous design requirements, including 20 T target

region fields. Support facility design will enable safe handling of components and environmental protection for the severe radiation conditions encountered. While new capabilities beyond current state of the art are not required, significant “engineering” type R&D efforts are needed for better understanding of graphite target survivability, beam absorber design, and magnet radiation tolerance.

We would like to address these issues beginning with a near term focused R&D program. This effort is complementary to the R&D plans now underway with the Brookhaven National Laboratory (BNL) experiment E9511 [5].

REFERENCES:

- [1] N.V. Mokhov, ‘ π/μ Yield and Power Dissipation for Carbon and Mercury Targets in 20-Tesla Solenoid with Matching Section’, Mucool Note MUC0061 (1999), <http://www-ap.fnal.gov/mokhov/mumu/target99/muc0061> and updates at <http://www-ap.fnal.gov/mokhov/mumu/target00>.
- [2] N.V. Mokhov, ‘The MARS Code System User Guide, Version 13(95)’, Fermilab-FN-628 (1995); N.V. Mokhov et al., Fermilab-Conf-98/379 (1998); LANL Report LA-UR-98-5716 (1998); nucl-th/9812038 v2, 16 Dec 1998; <http://www-ap.fnal.gov/MARS/>.
- [3] J.R. Miller et al., Teion Kogaku (Cryogenic Engineering – Japan), 31 (1996) 240, J.R. Miller, ‘The Superconducting Outsert for the NHMFL 45 T Hybrid Magnet System’, abstract to Applied Superconductivity Conference, Virginia Beach, VA, 17-22 Sep 2000.
- [4] Spallation Neutron Source Design Manual, Chapter 6, Target Systems, 12 Oct 1998, <http://www.ornl.gov/sns/dm/DesignManual.html>.
- [5] An R&D Program for Targetry at a Muon Collider, J.Alessi et al, proposal to the BNL AGS (Sept. 1998); also:
- [6] <http://puhep1.princeton.edu/mumu/target/targetprop.ps>