

Carbon and Mercury Targets for Neutrino Beams and a Muon Collider Source

(BNL E951)

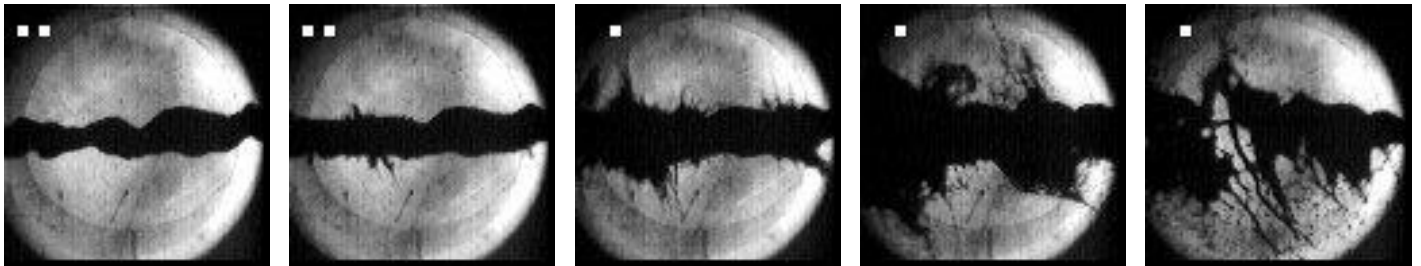
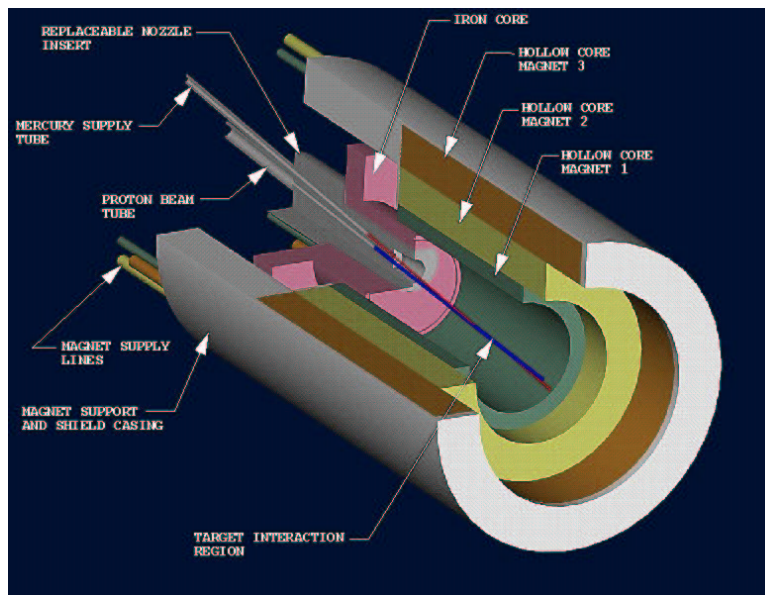

K.T. McDonald

Princeton U.

Muon Collider and Neutrino Factory Collaboration Meeting

Shelter Island, May 9, 2002

<http://puhep1.princeton.edu/mumu/target/>

Challenges

- Maximal production of soft pions → muons in a megawatt proton beam.
- Capture pions in a 20-T solenoid, followed by a 1.25-T decay channel.

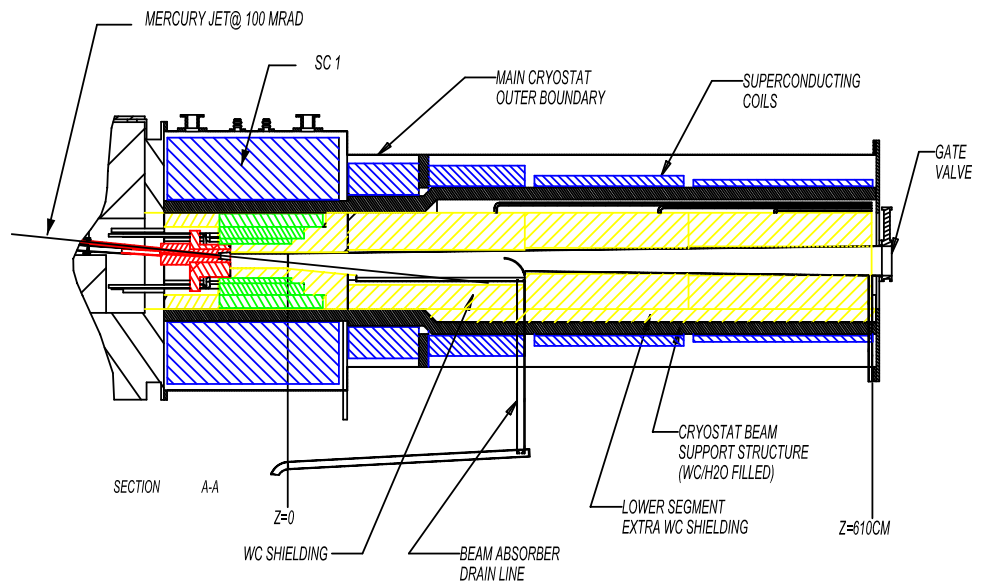
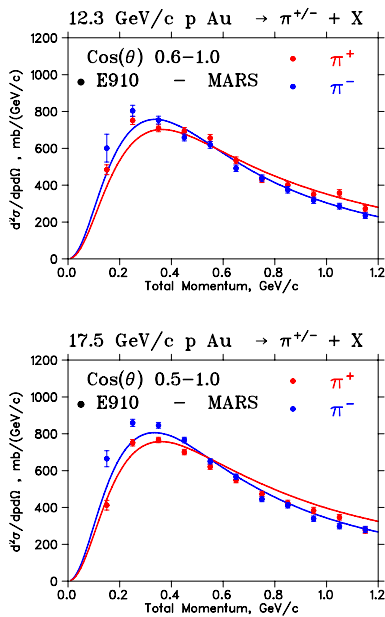

- A carbon target is feasible for 1.5-MW proton beam power.
- For $E_p \gtrsim 16$ GeV, factor of 2 advantage with high- Z target.
- Static high- Z target would melt, ⇒ Moving target.
- A free mercury jet target is feasible for beam power of 4 MW (and more).

The Neutrino Horn Issue

- A precursor to a Neutrino Factory is a Neutrino Superbeam based on decay of pions from a multimegawatt proton target station.
- 4 MW proton beams are achieved in both the BNL and FNAL (and CERN) scenarios via high rep rates: $\approx 10^6$ /day.
- Classic neutrino horns based on high currents in conductors that intercept much of the secondary pions will have lifetimes of only a few days in this environment.
- Consider instead a solenoid horn with conductors at larger radii than the pions of interest – similar to the Neutrino Factory capture solenoid.
- Adiabatic reduction of the solenoid field along the axis,
⇒ Adiabatic reduction of pion transverse momentum,
⇒ Focusing.

See, <http://pubweb.bnl.gov/users/kahn/www/talks/Homestake.pdf>

A Carbon Target is Feasible at 1-MW Beam Power

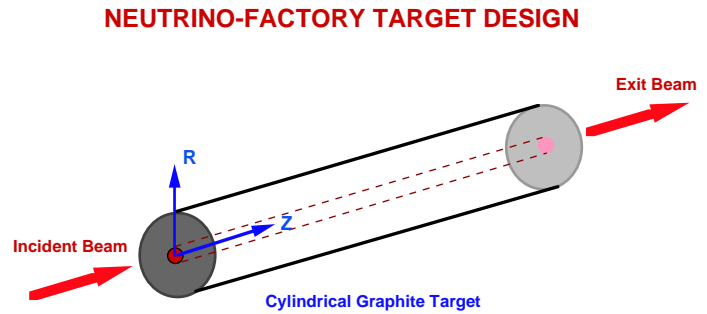
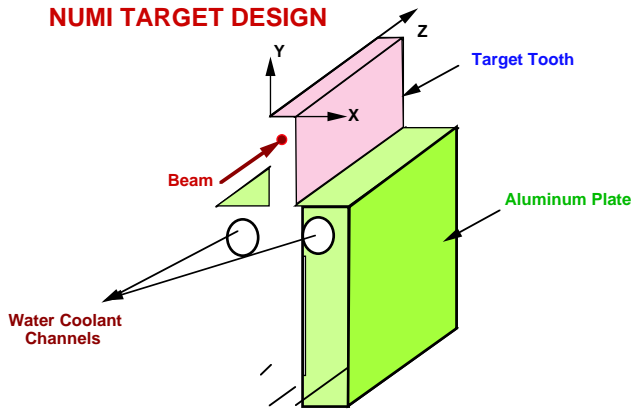

HASSANEIN (ANL)

A carbon-carbon composite with near-zero thermal expansion is largely immune to beam-induced pressure waves.

Sublimation of carbon is negligible in a helium atmosphere.

Radiation damage is limiting factor: ≈ 12 weeks at 1 MW.

A rotating band target is another option:

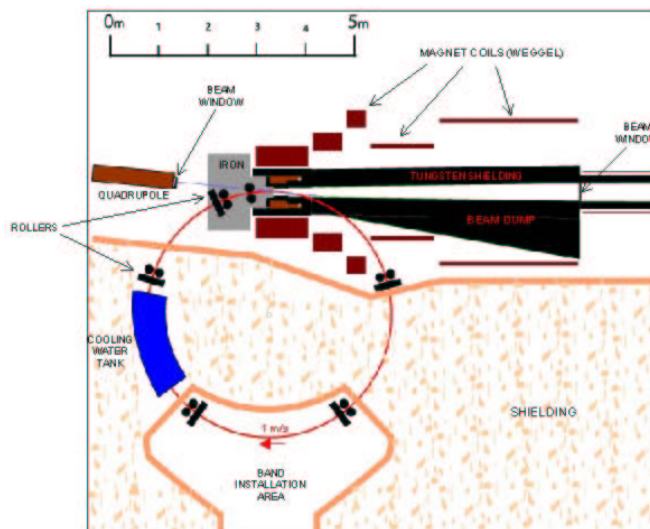

Pion/Muon Yield

For $E_p \gtrsim 10$ GeV, more yield with high- Z target.

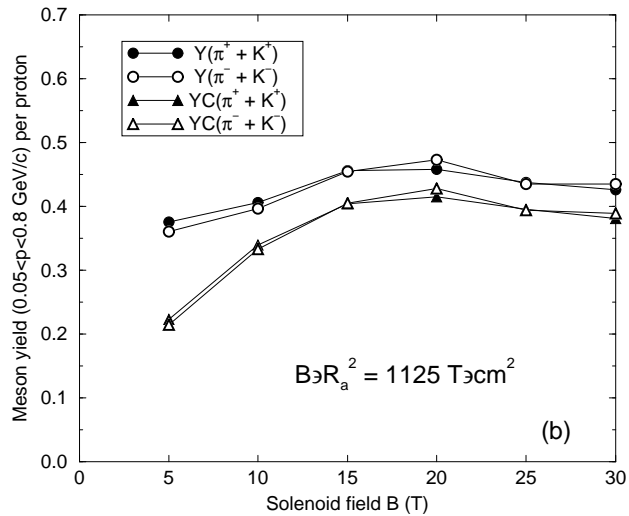

Mercury target radius should be ≈ 5 mm,
with target axis tilted by ≈ 100 mrad to the magnetic axis.

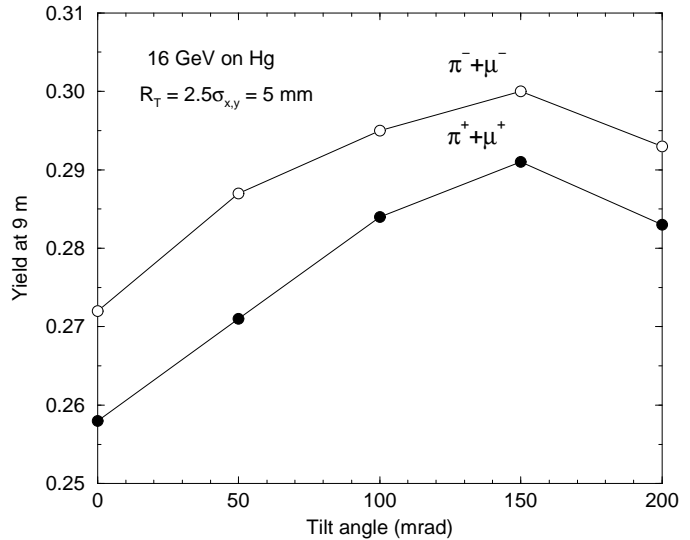
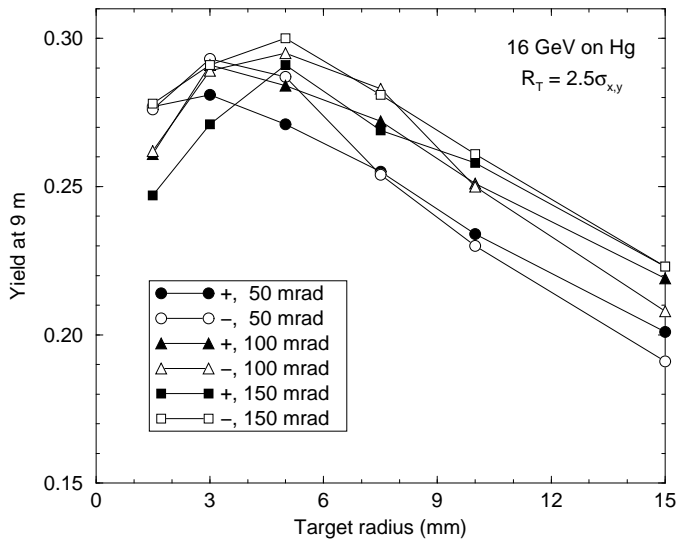

Can capture ≈ 0.3 pion per proton with $50 < P_\pi < 400$ MeV/ c .

Target System Layout

Mercury jet target inside a magnetic bottle: 20-T around target, dropping to 1.25 T in the pion decay channel.

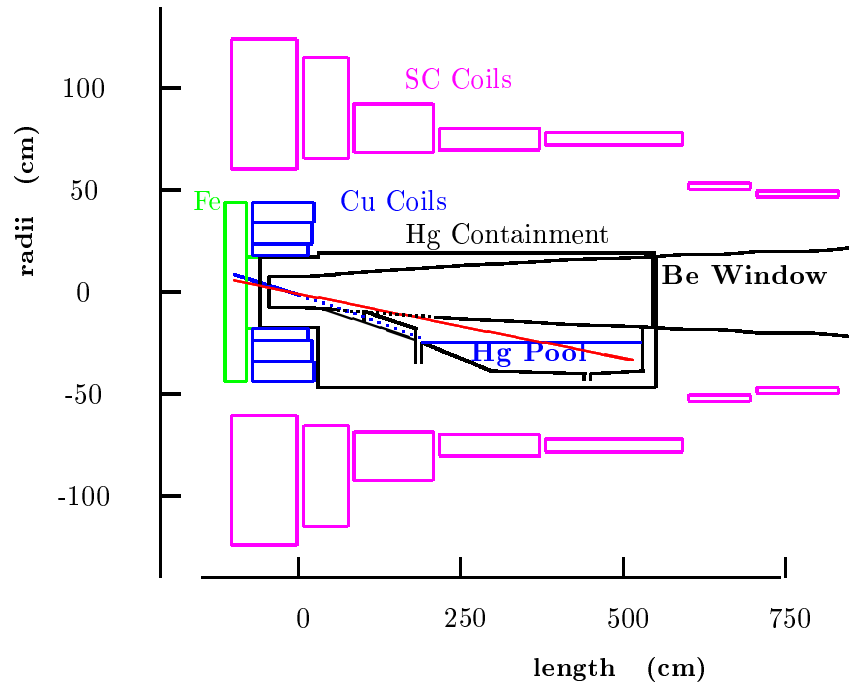

Mercury jet tilted by 100 mrad, proton beam by 67 mrad.

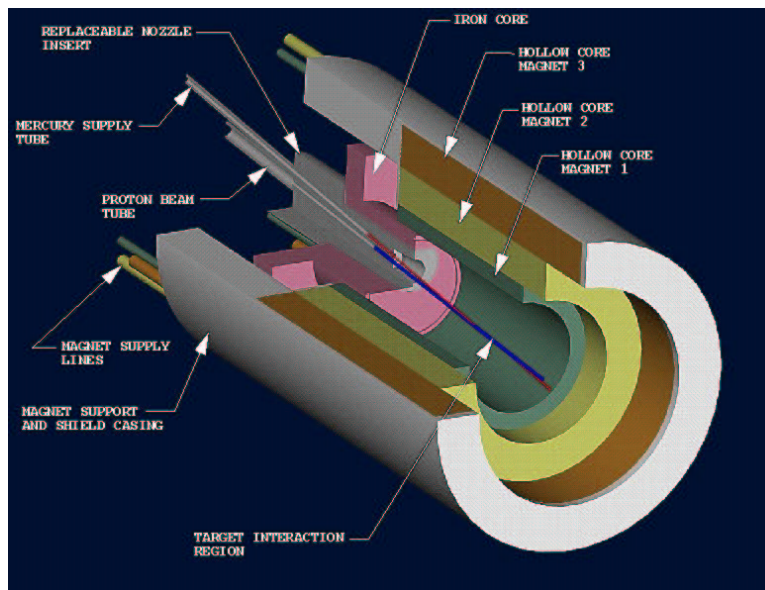

Lifetime of Components in the High Radiation Environment

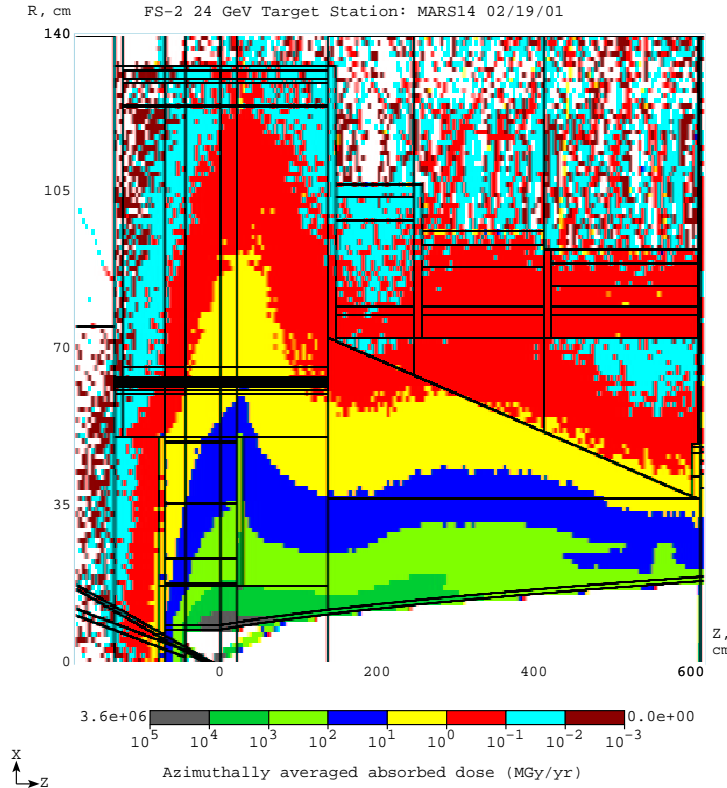

Component	Radius (cm)	Dose/yr (Grays/ 2×10^7 s)	Max allowed Dose (Grays)	1 MW Life (years)	4 MW life (years)
Inner shielding	7.5	5×10^{10}	10^{12}	20	5
Hg containment	18	10^9	10^{11}	100	25
Hollow conductor coil	18	10^9	10^{11}	100	25
Superconducting coil	65	5×10^6	10^8	20	5

Some components must be replaceable.

Viability of Targetry and Capture For a Single Pulse

- Beam energy deposition may disperse the jet.

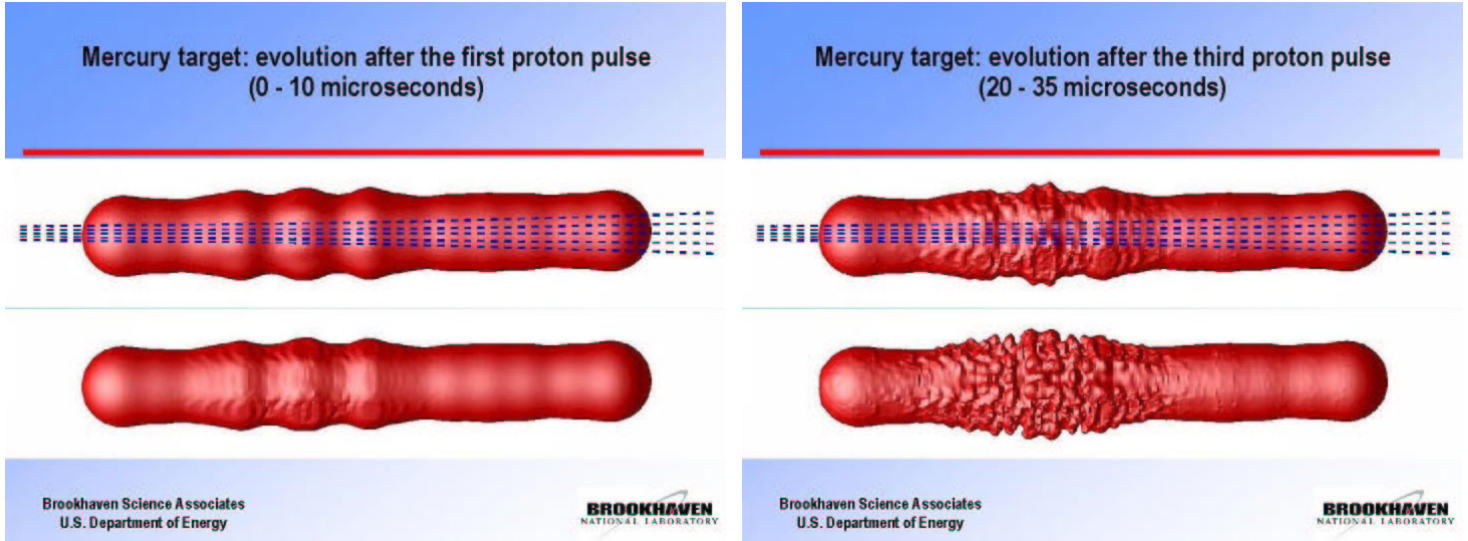

- Eddy currents may distort the jet as it traverses the magnet.

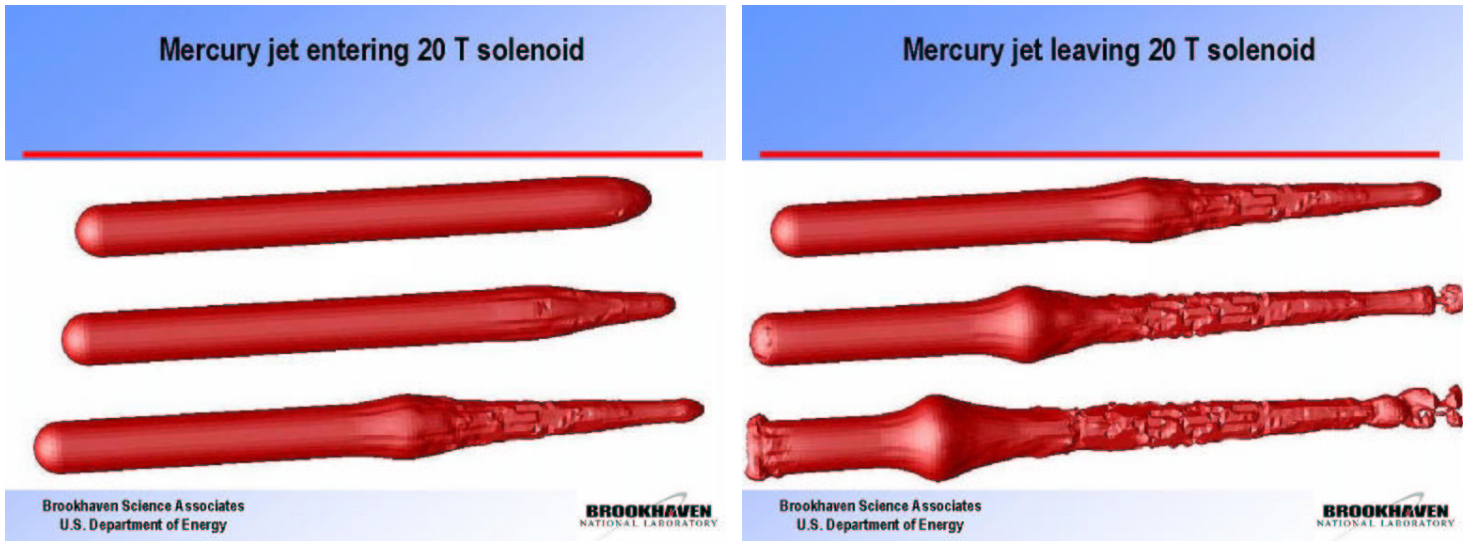

E951 Studies the Single Pulse Issues

Overall Goal: Test key components of the front-end of a neutrino factory in realistic single-pulse beam conditions.

Near Term (1-2 years): Explore viability of a liquid metal jet target in intense, short proton pulses and (separately) in strong magnetic fields.

Mid Term (3-4 years): Add 20-T magnet to beam tests; Test 70-MHz rf cavity (+ 1.25-T magnet) 3 m from target; Characterize pion yield.

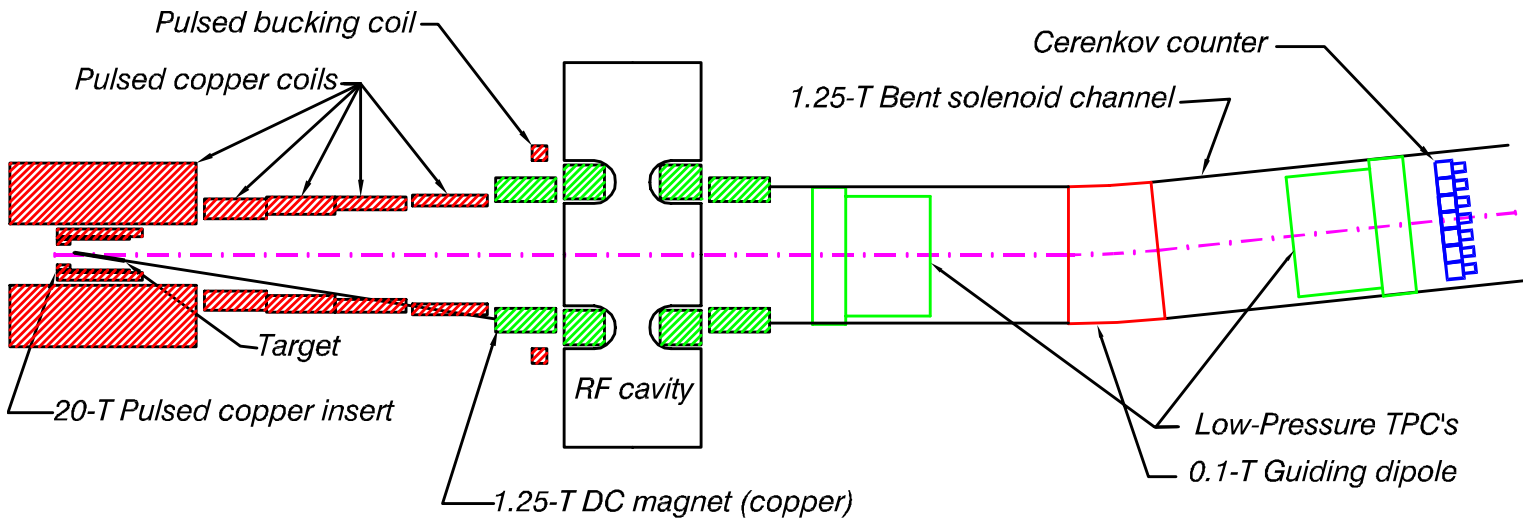

The E951 Collaboration

Audrey Bernadon,^d David Brashears,ⁱ Kevin Brown,^b Daniel Carminati,^d
Michael Cates,ⁱ John Corlett,^g F Debray,^f Adrian Fabich,^d Richard C. Fernow,^b
Charles Finfrock,^b Yasuo Fukui,^c Tony A. Gabriel,ⁱ Juan C. Gallardo,^b
Michael A. Green,^g George A. Greene,^b John R. Haines,ⁱ Jerry Hastings,^b
Ahmed Hassanein,^a Colin Johnson,^d Stephen A. Kahn,^b Bruce J. King,^b
Harold G. Kirk,^{b,1} Jacques Lettry,^d Vincent LoDestro,^b Changguo Lu,^j
Kirk T. McDonald,^{j,2} Nikolai V. Mokhov,^e Alfred Moretti,^e James H. Norem,^a
Robert B. Palmer,^b Ralf Prigl,^b Helge Ravn,^d Bernard Riemer,ⁱ James Rose,^b
Thomas Roser,^b Joseph Scaduto,^b Danial Schaffarzick,^d Peter Sievers,^d
Nicholas Simos,^b Philip Spampinato,ⁱ Iuliu Stumer,^b Peter Thieberger,^b
James Tsai,ⁱ Thomas Tsang,^b Haipeng Wang,^b Robert Weggel,^b
Albert F. Zeller,^h Yongxiang Zhao^b

^aArgonne National Laboratory, Argonne, IL 60439

^bBrookhaven National Laboratory, Upton, NY 11973

^cUniversity of California, Los Angeles, CA 90095

^dCERN, 1211 Geneva, Switzerland

^eFermi National Laboratory, Batavia, IL 60510

^fGrenoble High Magnetic Field Laboratory, 38042 Grenoble, france

^gLawrence Berkeley National Laboratory, Berkeley, CA 94720

^hMichigan State University, East Lansing, MI 48824

ⁱOak Ridge National Laboratory, Oak Ridge, TN 37831

^jPrinceton University, Princeton, NJ 08544

¹Project Manager. Email: kirk@electron.cap.bnl.gov

²Spokesperson. Email: mcdonald@puphep.princeton.edu

Solid Target Tests (5e12 ppp, 24 GeV, 100 ns)

Carbon, aluminum, Ti90Al6V4, Inconel 708, Havar, instrumented with fiberoptic strain sensors.

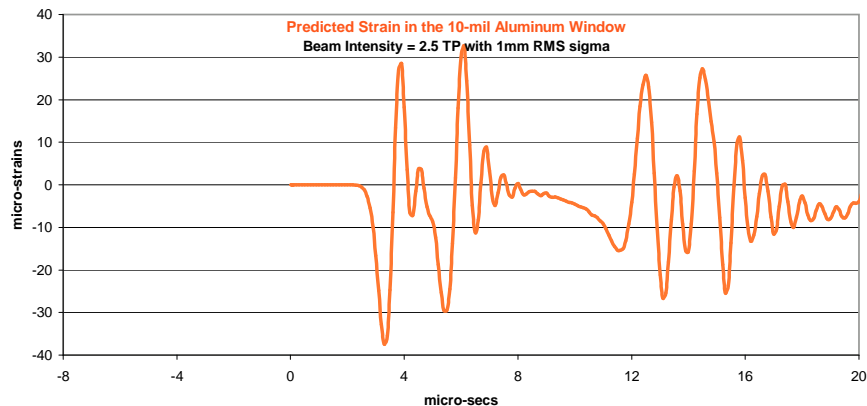
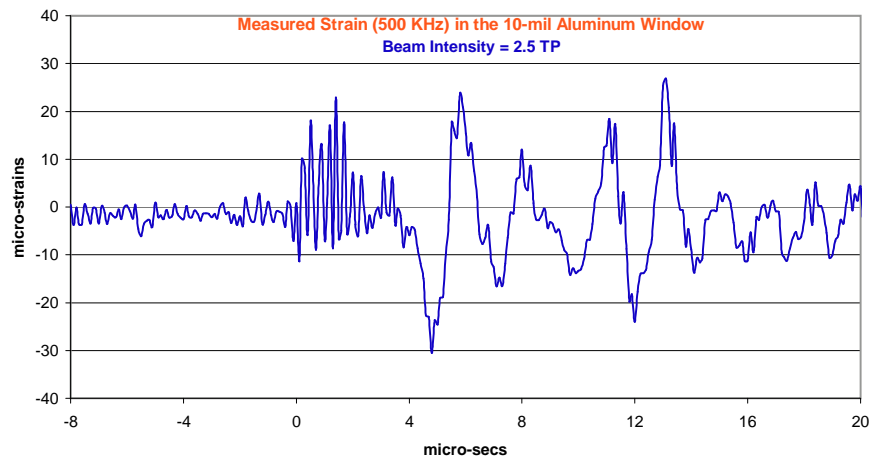
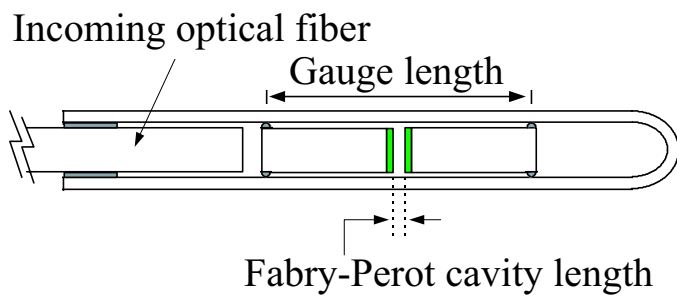

Passive Mercury Target Tests

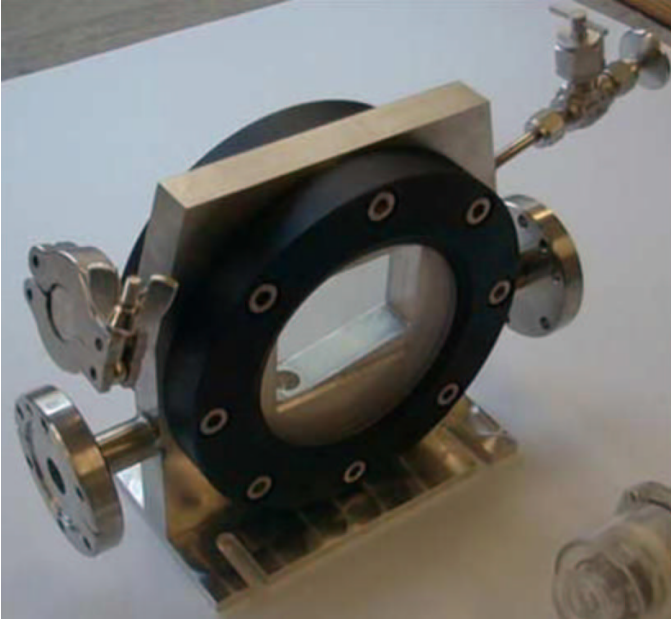

Exposures of $25 \mu\text{s}$ at
 $t = 0, 0.5, 1.6, 3.4 \text{ msec}$,
 $\Rightarrow v_{\text{splash}} \approx 20 - 40 \text{ m/s}$:

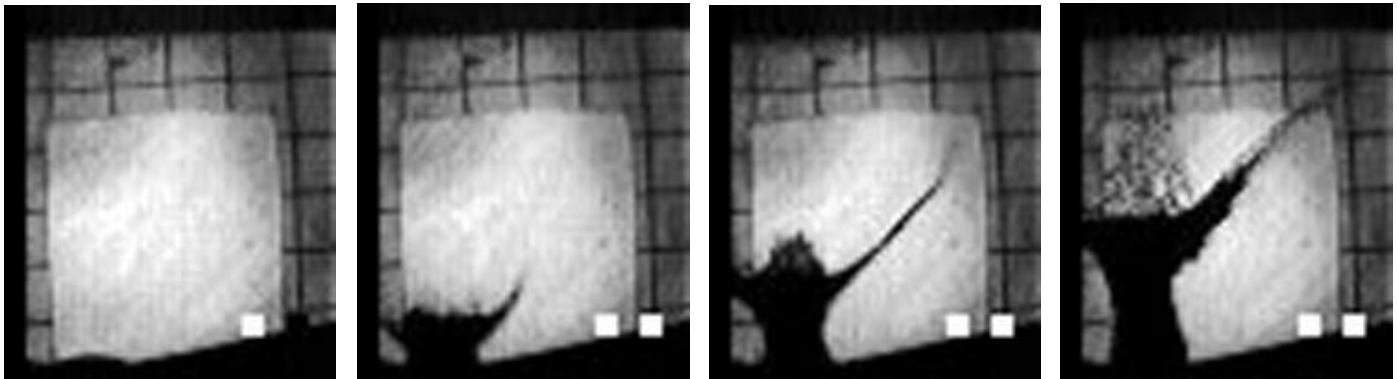

Two pulses of $\approx 250 \text{ ns}$ give larger dispersal velocity only if separated by less than $3 \mu\text{s}$.

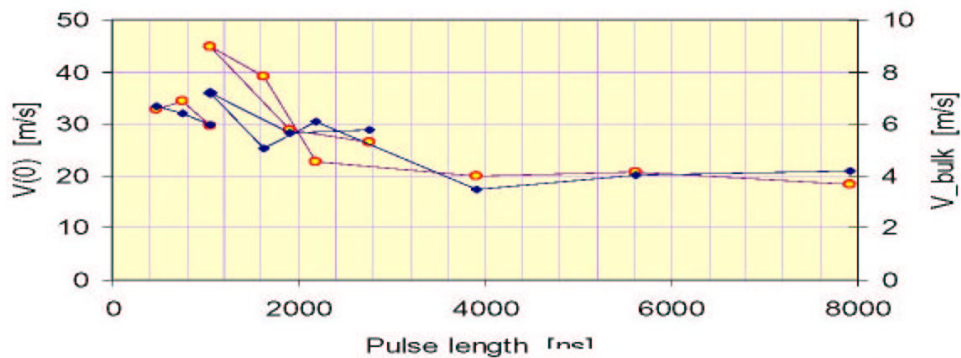

Studies of Proton Beam + Mercury Jet

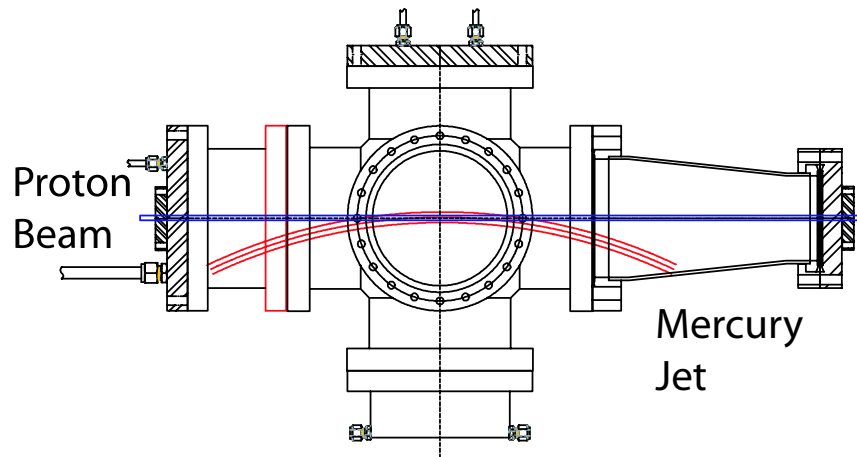

1-cm-diameter Hg jet in $2e12$ protons at $t = 0, 0.75, 2, 7, 18$ ms.

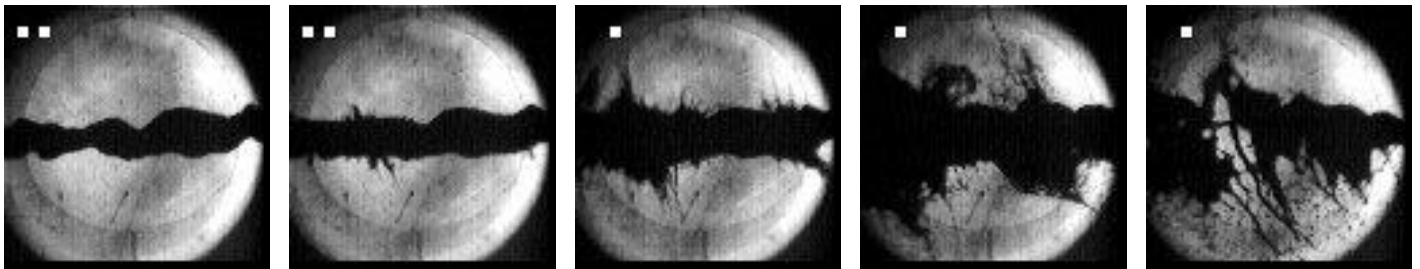

$$\text{Model: } v_{\text{dispersal}} = \frac{\Delta r}{\Delta t} = \frac{r\alpha\Delta T}{r/v_{\text{sound}}} = \frac{\alpha U}{C} v_{\text{sound}} \approx 50 \text{ m/s}$$

for $U \approx 100 \text{ J/g}$.

Data: $v_{\text{dispersal}} \approx 10 \text{ m/s}$ for $U \approx 25 \text{ J/g}$.

$v_{\text{dispersal}}$ appears to scale with proton intensity.

The dispersal is not destructive.

Tests of a Mercury Jet in a 13 T Magnetic Field (CERN/Grenoble High Magnetic Field Laboratory)

Eddy currents may distort the jet as it traverses the magnet.

Analytic model suggests little effect if jet nozzle inside field.

4 mm diam. jet, $v = 4.6$ m/s, $B = 0$ T; $v = 4.0$ m/s, $B = 13$ T:

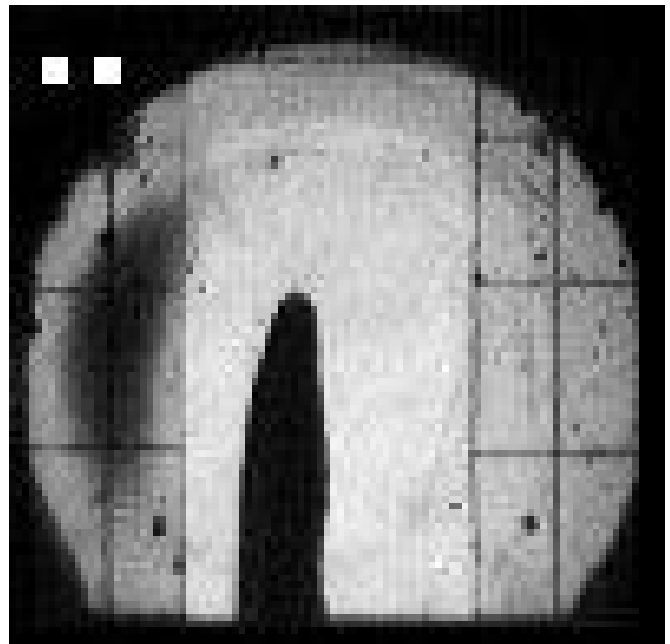
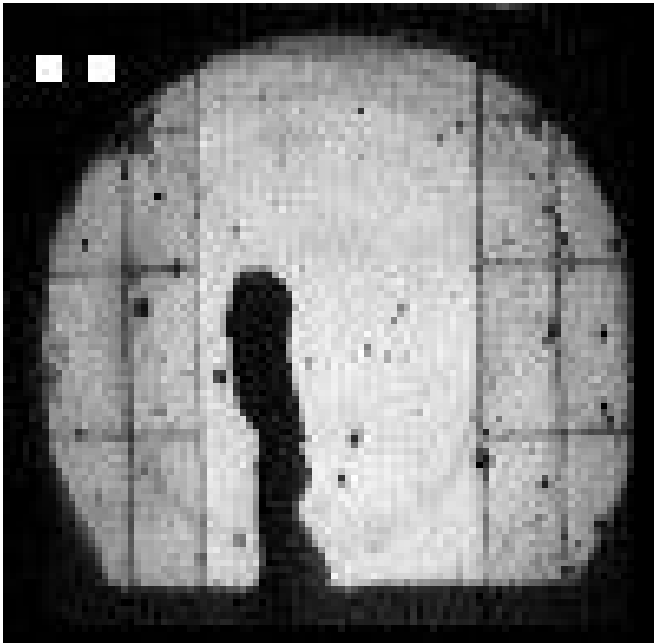

⇒ Damping of surface tension waves (Rayleigh instability).

20-T Capture Magnet System

Inner, hollow-conductor copper coils generate 6 T @ 12 MW:

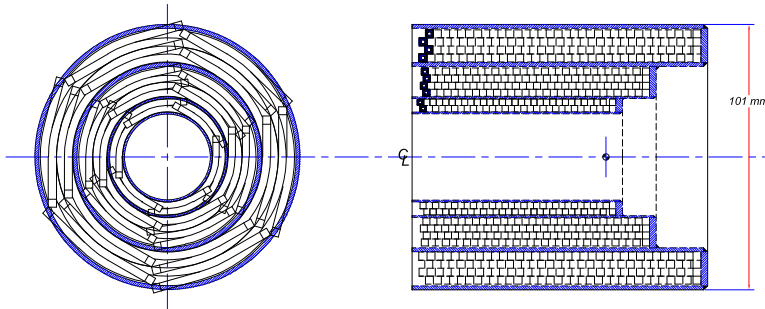

Bitter-coil option less costly, but marginally feasible.

Outer, superconducting coils generate 14 T @ 600 MJ:

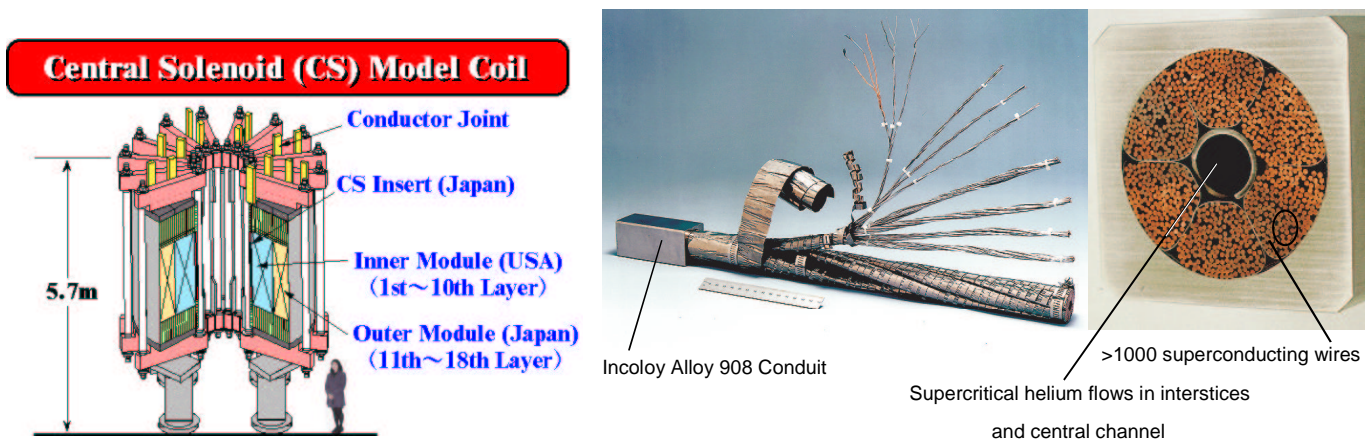

Cable-in-conduit construction similar to ITER central solenoid.

Both coils shielded by tungsten-carbide/water.

Target System Support Facility

Extensive shielding; remote handling capability.

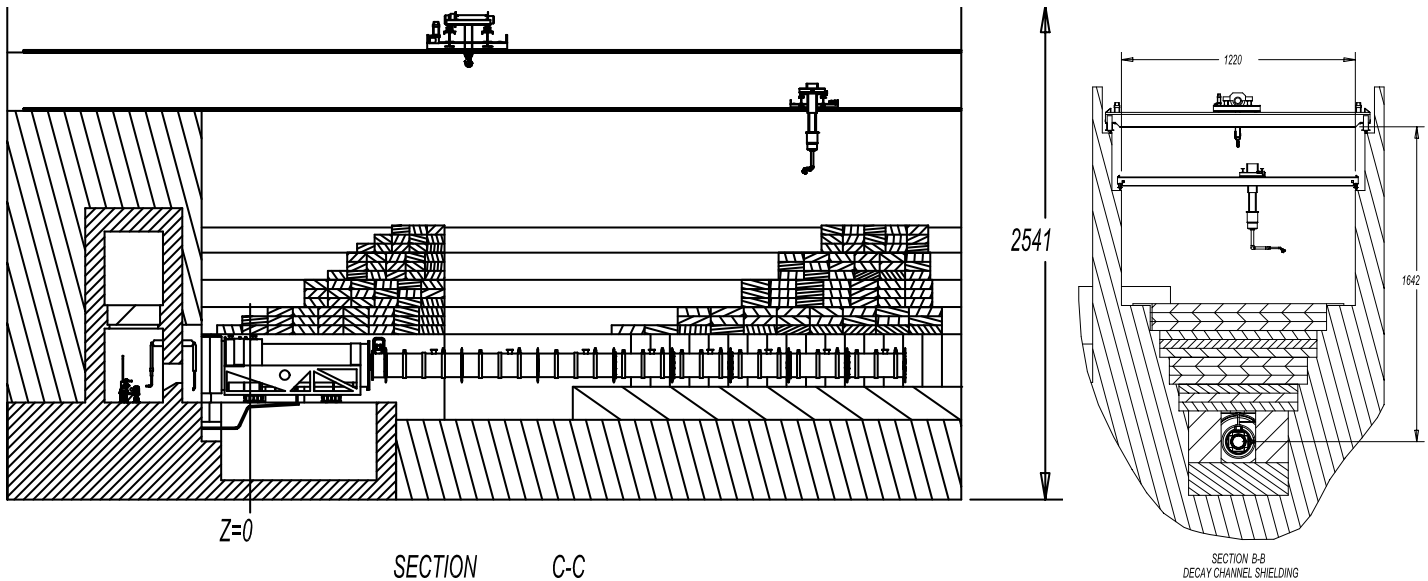
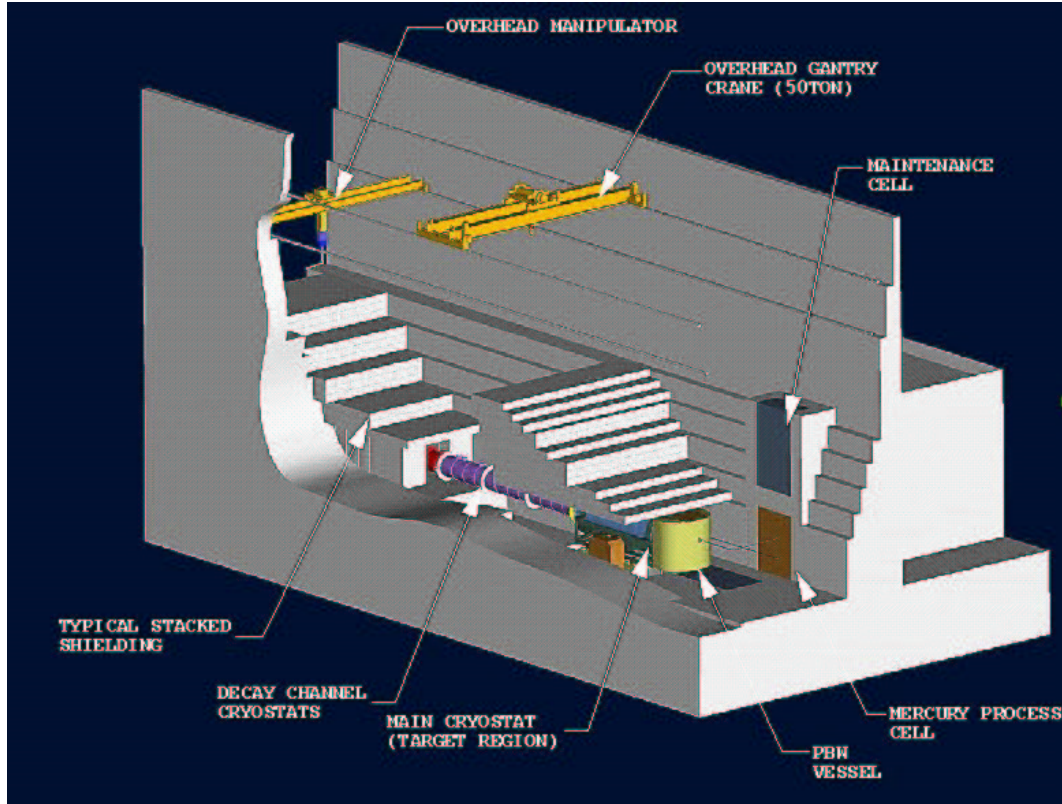

Summary of Targetry Activities Through FY01

- Liquid metal targets in vessels show beam-induced cavitation damage to entrance window (ISOLDE, 1995, LANL, 2001).
- Beam tests of large passive mercury target for SNS (BNL 1998, LANL 2000) suggest velocity of sound may be reduced temporarily by beam-induced microcavitation).
- MARS simulations of beam-target interactions \Rightarrow advantage of high- Z target, of high-field capture solenoid, of tilted beam and target, and disadvantages of high radiation dose (Mokhov).
- Analytic simulations of beam-induced pressure waves in target (Sievers), and of MHD effects of mercury jet entering magnet (KTM, Palmer, Weggel) indicate “feasibility”, but need for R&D.
- Numerical simulations (Hassanein, Samulyak) tend to confirm these analytic estimates.

- Beam tests of high-strength solid targets show good agreement between strain-sensor data and ANSYS simulation, and suggest that they can survive single-pulse stresses up to Study-2 design intensity, $= 16 \text{ TP} / 8 \text{ mm}^2$ (BNL, March '01).
- Calculation and experiment indicate that a carbon target could survive against sublimation in a He atmosphere in a 4 MW beam (Thieberger, ORNL).
- Beam tests of active and passive mercury targets indicate dispersal velocities of manageable size, proportional to proton pulse energy (BNL, April '01; ISOLDE, Aug. '01).
- Tests of mercury jets entering a high-field solenoid not yet definitive (CERN, Grenoble, 2001).

Issues for Further Targetry R&D

- Continue numerical simulations of MHD + beam-induced effects [Samulyak].
- Continue tests of mercury jet entering magnet [CERN, Grenoble].
- For solid targets, study radiation damage – and issues of heat removal from solid metal targets (bands, chains, *etc.*).
- Confirm manageable mercury-jet dispersal in beams up to full Study-2 intensity – for which single-pulse vaporization may also occur. Test Pb-Bi alloy jet.
- Study issues when combine intense proton beam with mercury jet inside a high-field magnet.
 1. MHD effects in prototype target configuration.
 2. Magnetic damping of mercury-jet dispersal.
 3. Beam-induced damage to jet nozzle – in the magnetic field.

Further Beam Studies without High-Field Magnet

- Studies of production of mercury jets up to 20 m/s. Jet quality is the issue.
- Construction of new liquid metal jet targets with continuous flow: mercury and Wood's metal.
- Upgrade AGS to 8/16 TP single pulses [Roser].
 1. Improve control of fast extraction with bipolar power supply for a key vertical sextupole.
 2. Improve control of chromaticity of bunches during transition with heftier power supply for main ring horizontal sextupoles.
 3. Explore schemes for 2:1 bunch merging at 24 GeV via rf manipulation.
- Test the continuous-flow targets in beam once at least 8 TP per pulse are available.
- [Radiation damage studies of solid targets at BNL booster.]

Further Beam Studies with a High-Field Magnet

- Study jet dispersal, and possible damage to nozzle, as a function of beam intensity, magnetic field strength, and nozzle position.
- Online diagnostics will primarily be optical (+ possible use of fiberoptic strain sensors).

CERN/Grenoble optical system that fits in 20-cm magnet bore:

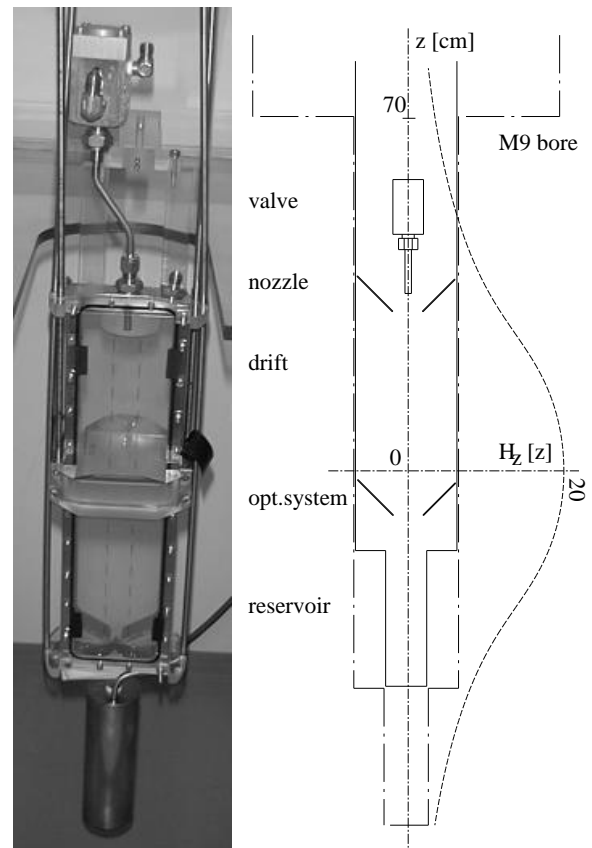

- To be affordable, construct a 15-T pulsed solenoid magnet.

What Magnetic Field Strength is Appropriate?

- Our muon collider and neutrino factory designs have long called for a 20-T capture solenoid.

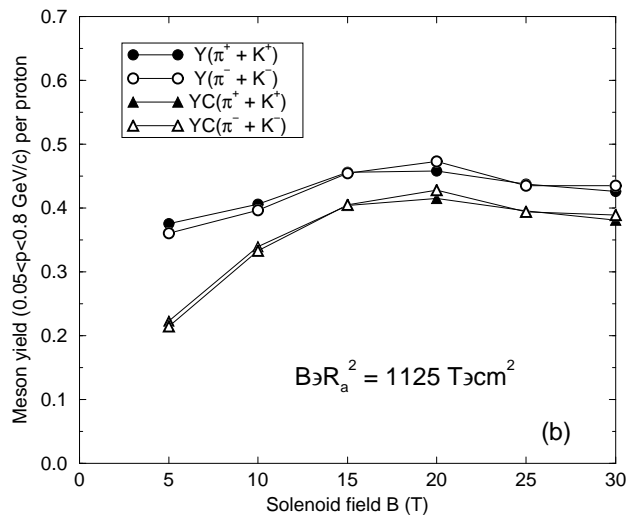

A 20-T magnet must be a hybrid: 6-T copper “insert” + 14-T superconducting “outsert”.

The small gain in performance from 14 to 20 T may not warrant the cost and complexity of the hybrid magnet.

A capture solenoid for a superbunch needs a larger bore to trap higher P_{\perp} pions, for which 14 T is then sufficient.

⇒ Our physics goals are well satisfied by a 14-T capture solenoid.

Should the Pulsed R&D Magnet have Lower Field?

- Most magnetic-field effects on the mercury jet scale as the magnetic pressure $B^2/8\pi$ (for a fixed geometry).
- Thus, a study using a 5-T magnet would require a factor of 8 extrapolation to the desired performance at 14 T.
- Present cost estimates indicate that we can build a 14-T pulsed magnet for about twice the cost of a 5-T pulsed magnet.
- \Rightarrow We propose to construct a 14.5-T pulsed magnet, that can be staged as a 5-T and 10-T magnet.

A 14.5-T Pulsed Magnet with 5- and 10-T Phased Options

14.5-T Pulsed Magnet (using all 3 coils)
 5- or 10-T magnet using inner 2 coils

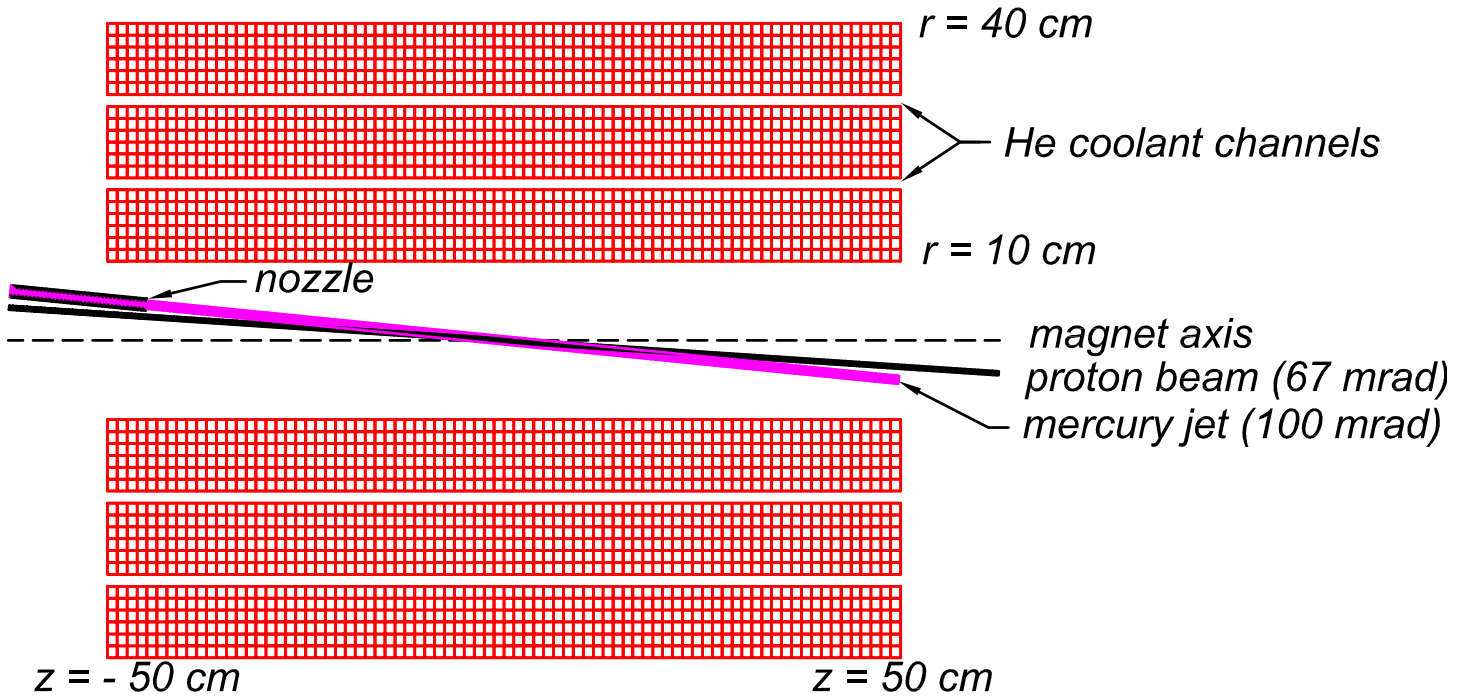

Phase	No. of PS	Coolant	Temp.	Field
1	1	N ₂	84 K	5 T
2	4	N ₂	74 K	10 T
3	4	H ₂	30 K	14.5 T

Keeping Costs Low

- Simple solenoid geometry with rectangular coil cross section and smooth bore (of 20 cm diameter) [Weggel, Titus].
- Power supply built out of 4 existing 540 kVA supplies that can be fed by a single, existing substation [Marneris].
- Cryogenic system reduces coil resistance to give high field at relatively low current [Iarocci].
 - Circulating coolant is gaseous He to minimize activation, and to avoid need to purge coolant before pulsing magnet.
 - Heat exchanger recycled from the SSC.
 - Phase 1 & 2 cooling via N₂ boiloff; Phase 3 via H₂.

Pulsed Magnet System Layout at the AGS

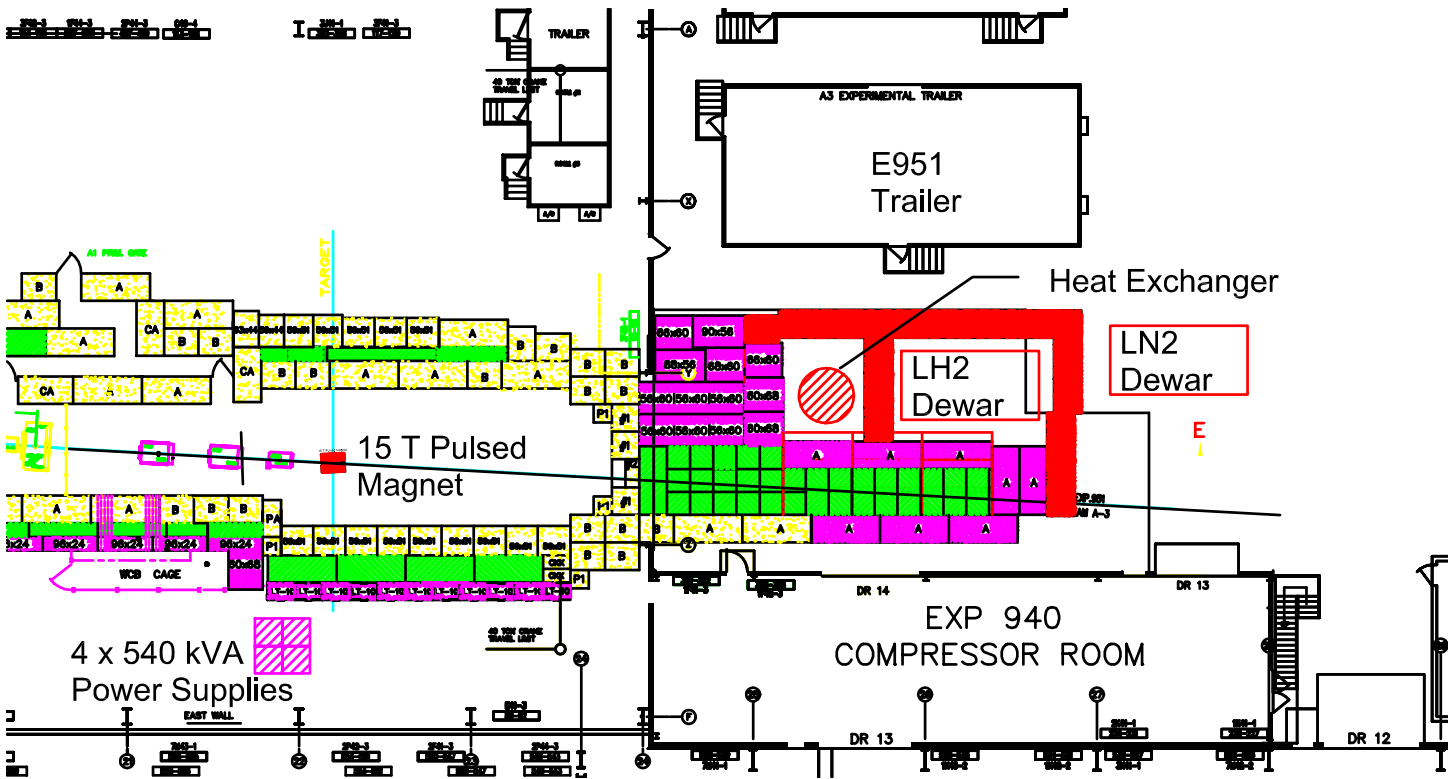

- Locate the 4 x 540 kVA power supplies on the east side of the A3 cave, feed power in via the trench.
- If satisfactory to Safety Committee, locate the heat exchanger and LH₂ dewar in a concrete enclosure that extends the present A3 beam stop.

Other Works in Progress

- AGS sextupole power supply upgrades (Brown, Sandberg).
- 2 \rightarrow 1 AGS bunch merging via rf manipulation (Brown, Brennan).
- 2nd round of liquid metal jets: 2.5 \rightarrow 20 m/s; Hg and Pb/Bi alloy (Kirk, McDonald).

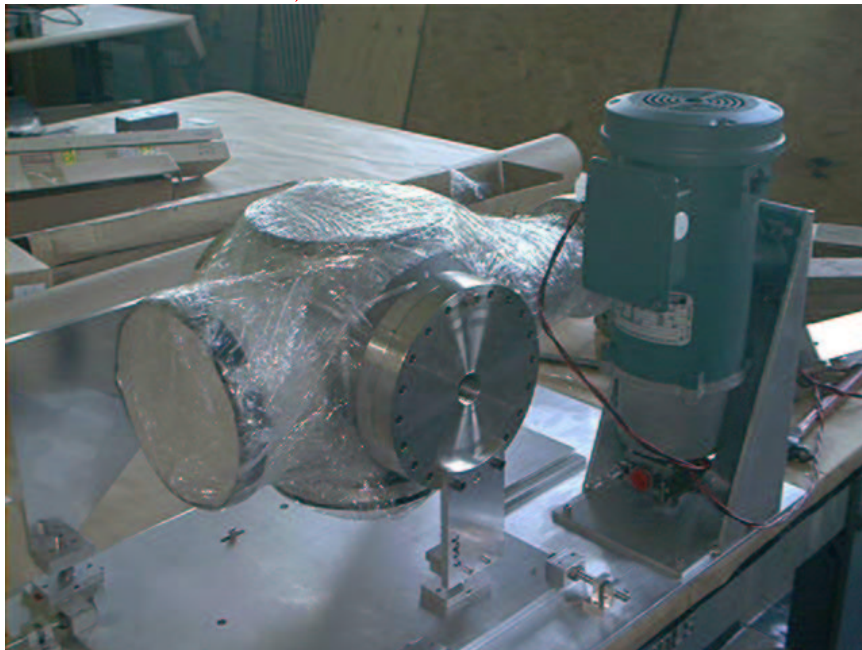

- Radiation damage studies of Invar at BLIP (Thieberger, Weggel).
- Graphite sublimation in a He atmosphere (Haines, Spampinato).
- FEA simulations (Samulyak).