

The High-Power Targetry R&D Program

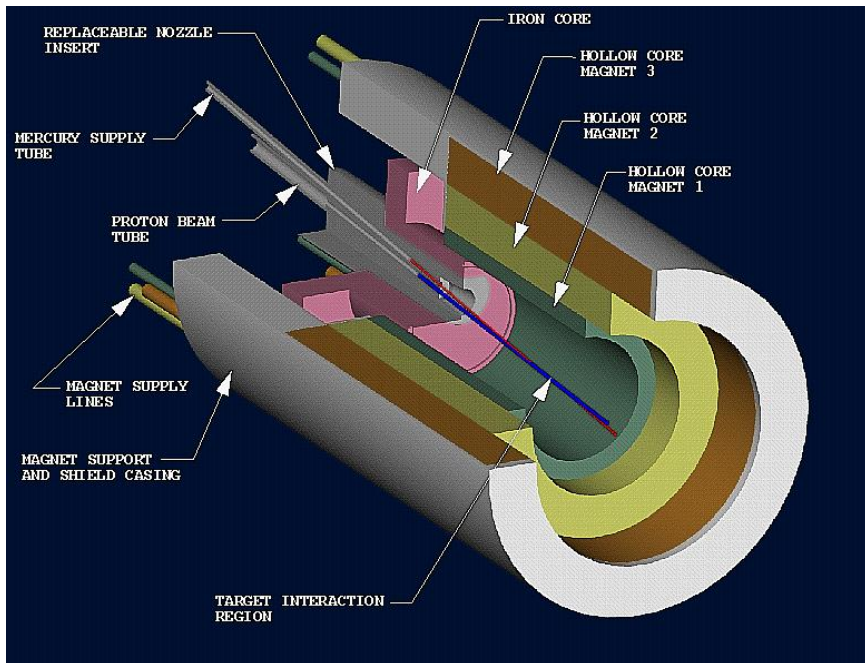

K.T. McDonald
Princeton U.
MUTAC Review
BNL, April 18, 2007

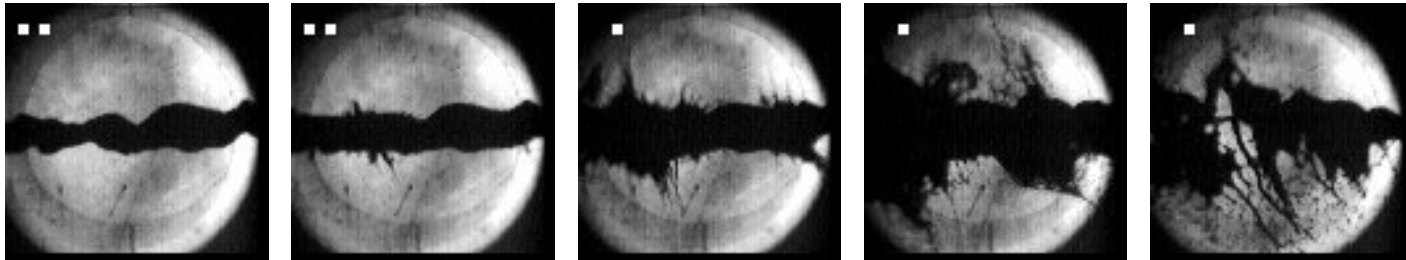

Targetry Web Page: <http://puhep1.princeton.edu/mumu/target/>

Why Targetry?

- **Targetry = the task of producing and capturing π 's and μ 's from proton interactions with a nuclear target.**
- **At a muon collider the key parameter is luminosity:**

$$\mathcal{L} = \frac{N_1 N_2 f}{A} \text{ s}^{-1} \text{ cm}^{-2},$$

⇒ **Gain as square of source strength (targetry),
but small beam area (cooling) is also critical.**

- **At a neutrino factory the key parameter is neutrino flux,
⇒ Source strength (targetry) is of pre-eminent concern.
[Beam cooling important mainly to be sure the beam fits in the pipe.]**
- **Since its inception the Neutrino Factory/Muon Collider Collaboration has recognized the importance of high-performance targetry, and has dedicated considerable resources towards R&D on advanced targetry concepts.**
- **The exciting results from atmospheric and reactor neutrino programs (Super-K, SNO, KamLAND) reinforce the opportunity for neutrino physics with intense accelerator neutrino beams, where targetry is a major challenge.**

High-Power Targets Essential for Many Future Facilities

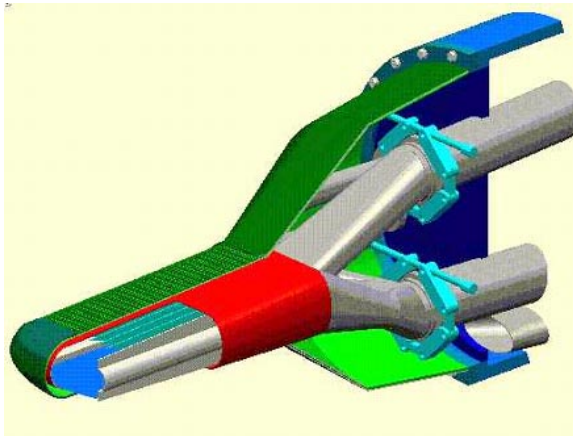

ESS

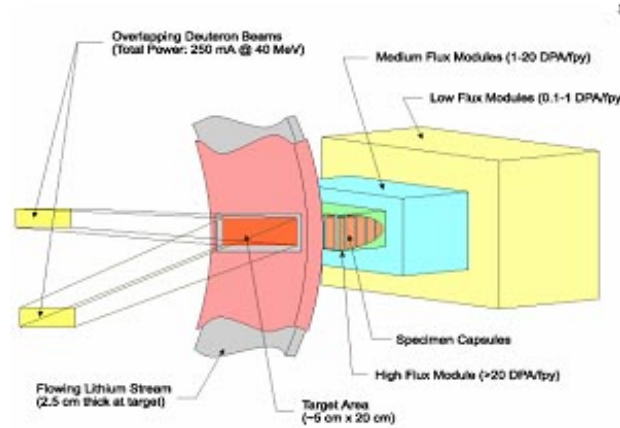

IFMIF

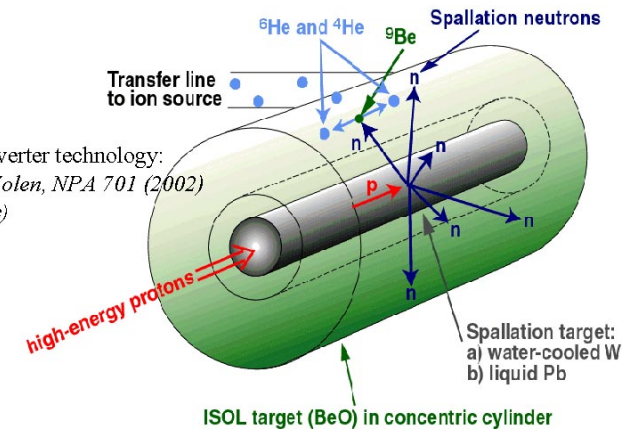

Converter technology:
(J. Nolen, NPA 701 (2002) 312c)

ISOL target (BeO) in concentric cylinder

ISOL/ β Beams

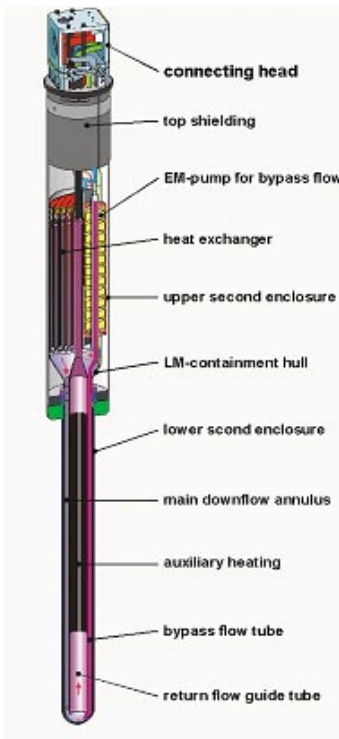

PSI

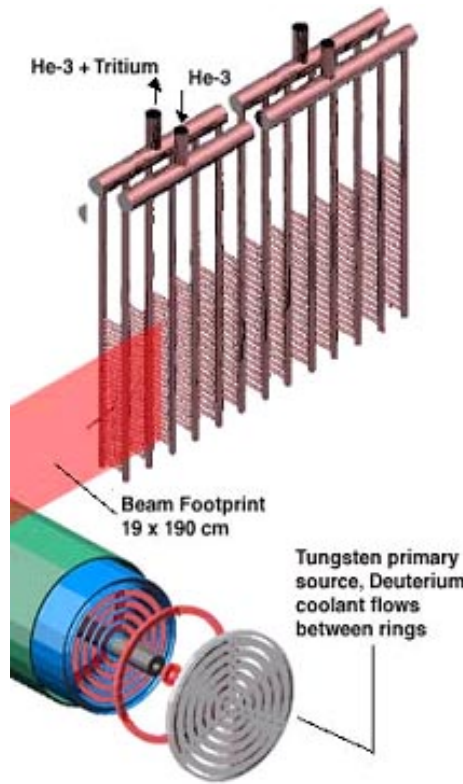

APT

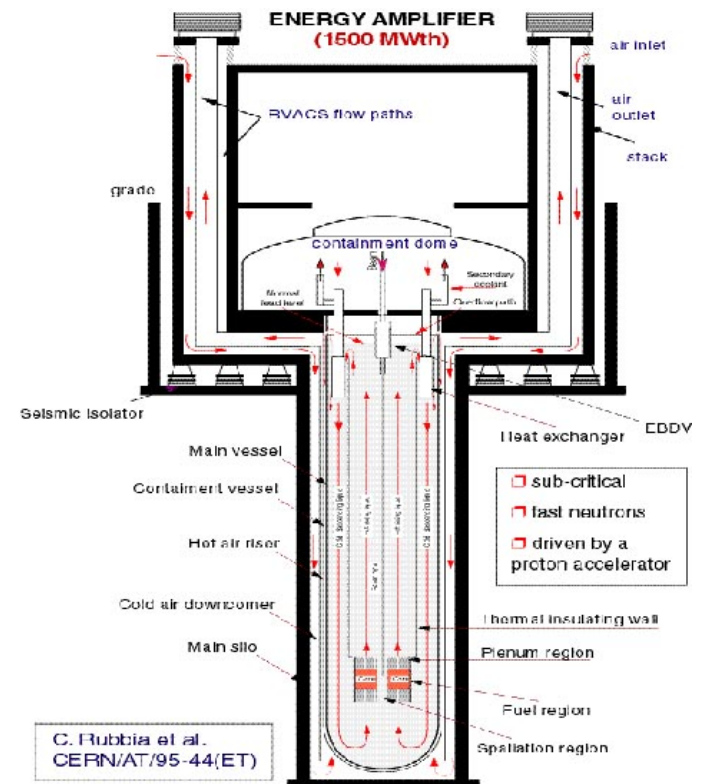

C. Rubbia et al. CERN/AT/95-44(ET)

ATW



The Challenges of High-Power Targetry

4-MW Proton Beam

- **10-30 GeV** appropriate for both Superbeam and Neutrino Factory.
 - ⇒ $0.8-2.5 \times 10^{15}$ pps; $0.8-2.5 \times 10^{22}$ protons per year of 10^7 s.
 - **Rep rate 15-50 Hz** at Neutrino Factory, as low as **2 Hz** for Superbeam.
 - ⇒ Protons per pulse from 1.6×10^{13} to 1.25×10^{15} .
 - ⇒ Energy per pulse from 80 kJ to 2 MJ.
 - **Small beam size preferred:**
 - ≈ 0.1 cm^2 for Neutrino Factory, ≈ 0.2 cm^2 for Superbeam.
- ⇒ **Severe materials issues for target AND beam dump.**
- **Radiation Damage.**
 - **Melting.**
 - **Cracking** (due to single-pulse “thermal shock”).

Radiation Damage is the Ultimate Limit

The lifetime dose against radiation damage (embrittlement, cracking, ...) by protons for most solids is about $10^{22}/\text{cm}^2$.

⇒ Target lifetime of about 5-14 days at a Neutrino Factory (and 9-28 days at a Superbeam).

⇒ Mitigate by frequent target changes, moving target, liquid target, ...

Remember the Beam Dump

Target of 2 interaction lengths ⇒ 1/7 of beam is passed on to the beam dump.

Long distance from target to dump at a Superbeam,

⇒ Beam is much less focused at the dump than at the target,

⇒ Radiation damage to the dump not a critical issue (Superbeam).

Short distance from target to dump at a Neutrino Factory,

⇒ Beam still tightly focused at the dump,

⇒ Frequent changes of the beam dump, or a moving dump, or a liquid dump.

A liquid beam dump is the most plausible option for a Neutrino Factory, independent of the choice of target. (This is so even for a 1-MW Neutrino Factory.)



Pion Yield

Pion/Muon Yield, I

ν Superbeams need $E_\pi \approx 0.5\text{-}5$ GeV, ν Factories need $E_\pi < 0.5$ GeV.

For $E_p \gtrsim 10$ GeV, more yield with high- Z target (MARS calculations).

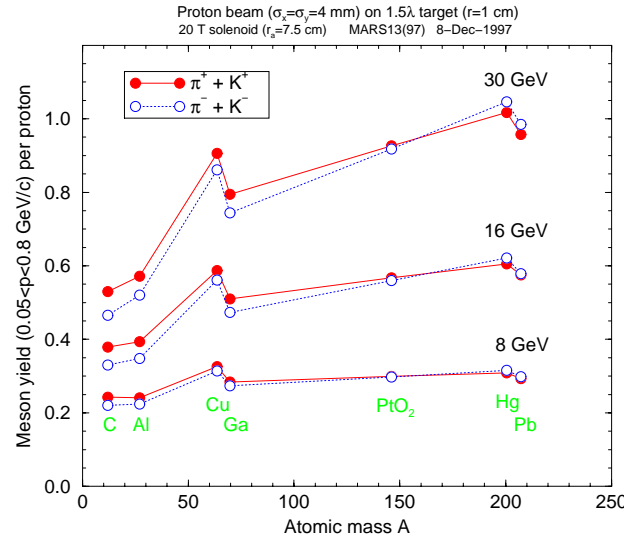

$$\frac{N^+_{10\text{GeV}}}{N^+_{24\text{GeV}}} = 1.07 \quad \frac{N^-_{10\text{GeV}}}{N^-_{24\text{GeV}}} = 1.10$$

$$\frac{N^+_{5\text{GeV}}}{N^+_{24\text{GeV}}} = 1.90 \quad \frac{N^-_{5\text{GeV}}}{N^-_{24\text{GeV}}} = 1.77$$

$$\frac{N^+_{\text{Hg-10GeV}}}{N^+_{\text{C-5GeV}}} = 1.18 \quad \frac{N^-_{\text{Hg-10GeV}}}{N^-_{\text{C-5GeV}}} = 1.22$$

Yield vs. target radius:

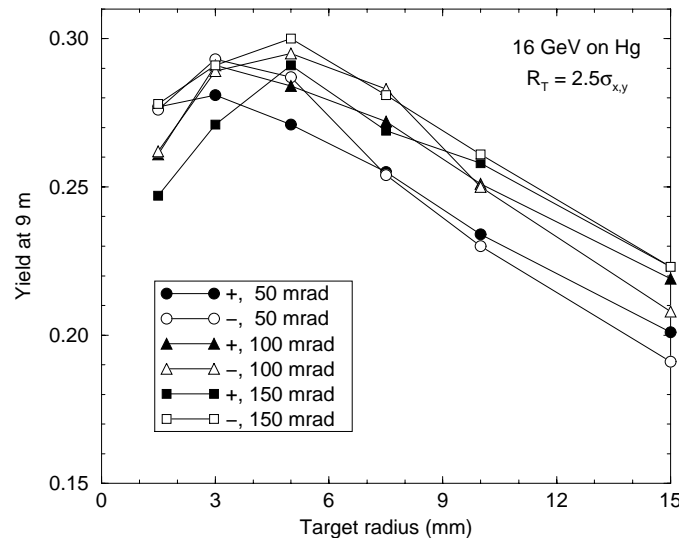

Ex: Mercury target radius should be ≈ 5 mm.

Pion/Muon Yield, II: Solenoid Capture

IF capture pions in a solenoid channel, should begin with a high-field “magnetic bottle”.

Yield *vs.* magnetic field for 15-cm bore:

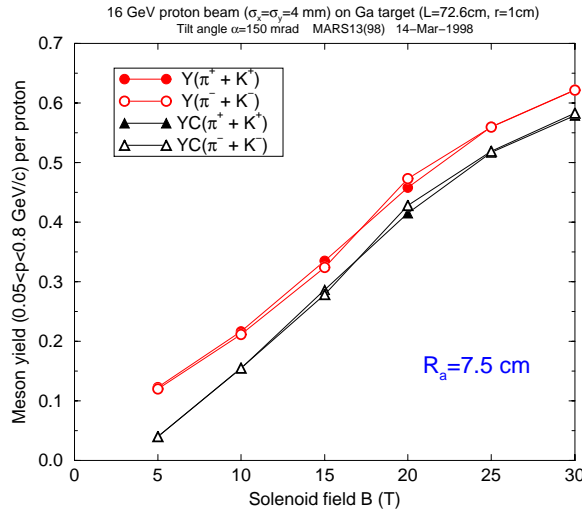

Yield *vs.* target tilt:

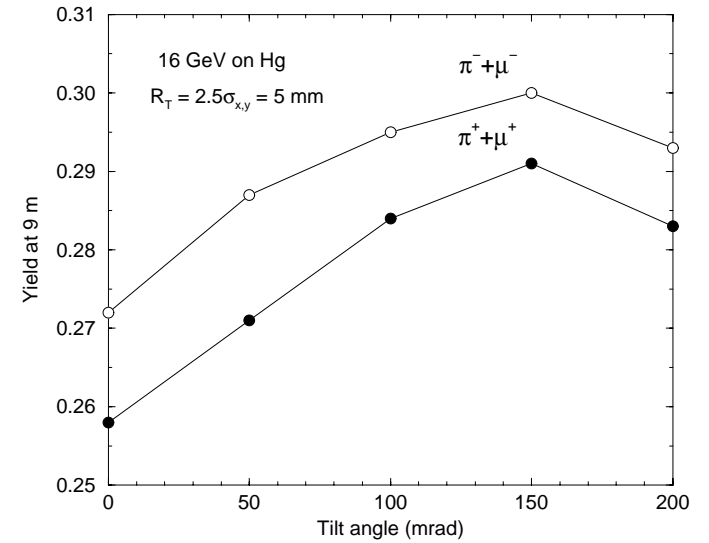

Tilt target axis by ≈ 100 mrad to the magnetic axis to increase yield of soft, large-angle pions.

Can capture ≈ 0.3 pion per proton with $50 < P_\pi < 400$ MeV/c.

Target Topologies

Target and Capture Topologies: Toroidal Horn

The traditional topology for efficient capture of secondary pions is a toroidal “horn” (Van der Meer, 1961).

- Collects only one sign, \Rightarrow Long data runs, but nonmagnetic detector (Superbeam).
- Inner conductor of toroid very close to proton beam.
 - \Rightarrow Limited life due to radiation damage at 4 MW.
 - \Rightarrow Beam, and beam dump, along magnetic axis.
 - \Rightarrow More compatible with Superbeam than with Neutrino Factory.

Carbon composite target with He gas cooling (BNL study):

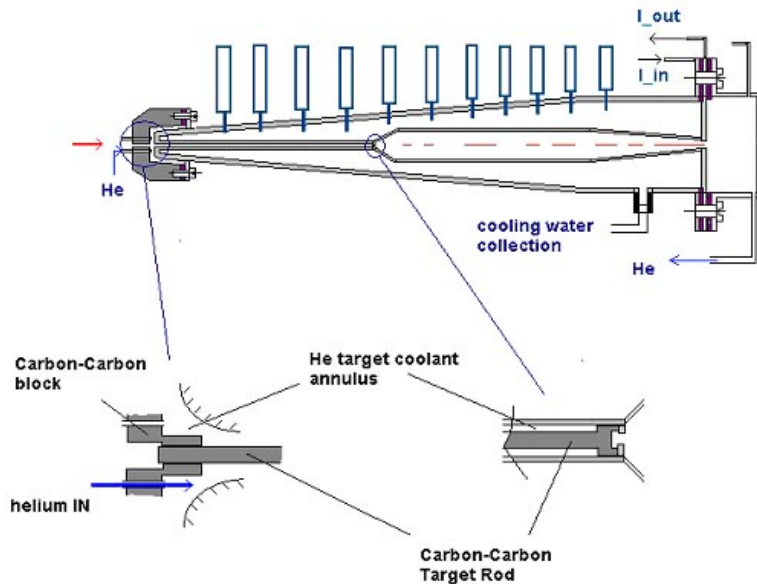

Mercury jet target (CERN SPL study):

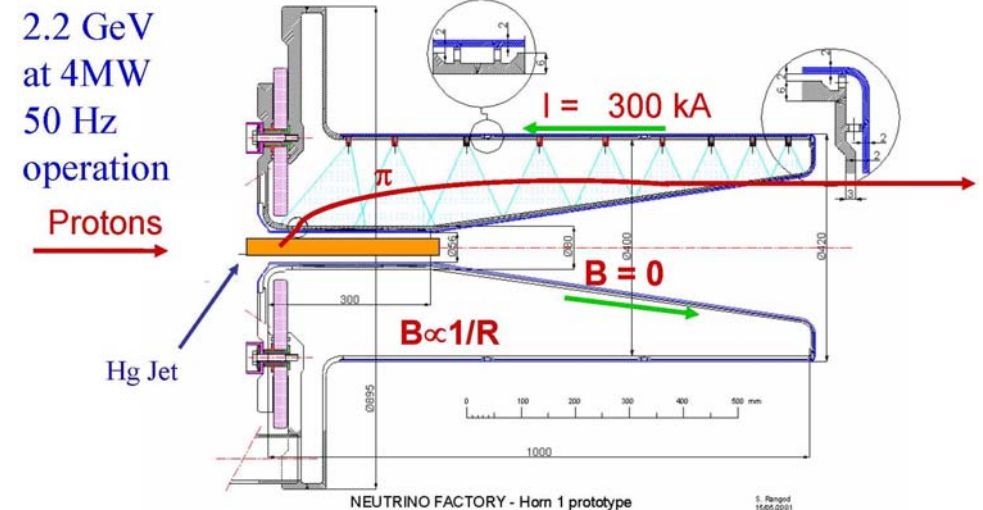

If desire secondary pions with $E_\pi \lesssim 5$ GeV (Neutrino Factory), a high- Z target is favored, but for $E_\pi \gtrsim 10$ GeV (some Superbeams), low Z is preferred.

Target and Capture Topologies: Solenoid

Palmer (1994) proposed a solenoidal capture system for a Neutrino Factory.

- Collects both signs of π 's and μ 's, \Rightarrow Shorter data runs (with magnetic detector).
- Solenoid coils can be some distance from proton beam.

$\Rightarrow \gtrsim 4$ year life against radiation damage at 4 MW.

\Rightarrow Proton beam readily tilted with respect to magnetic axis.

\Rightarrow Beam dump out of the way of secondary π 's and μ 's.

Mercury jet target and proton beam tilt downwards with respect to the horizontal magnetic axis of the capture system.

The mercury collects in a pool that serves as the beam dump (Neutrino Factory Study 2):

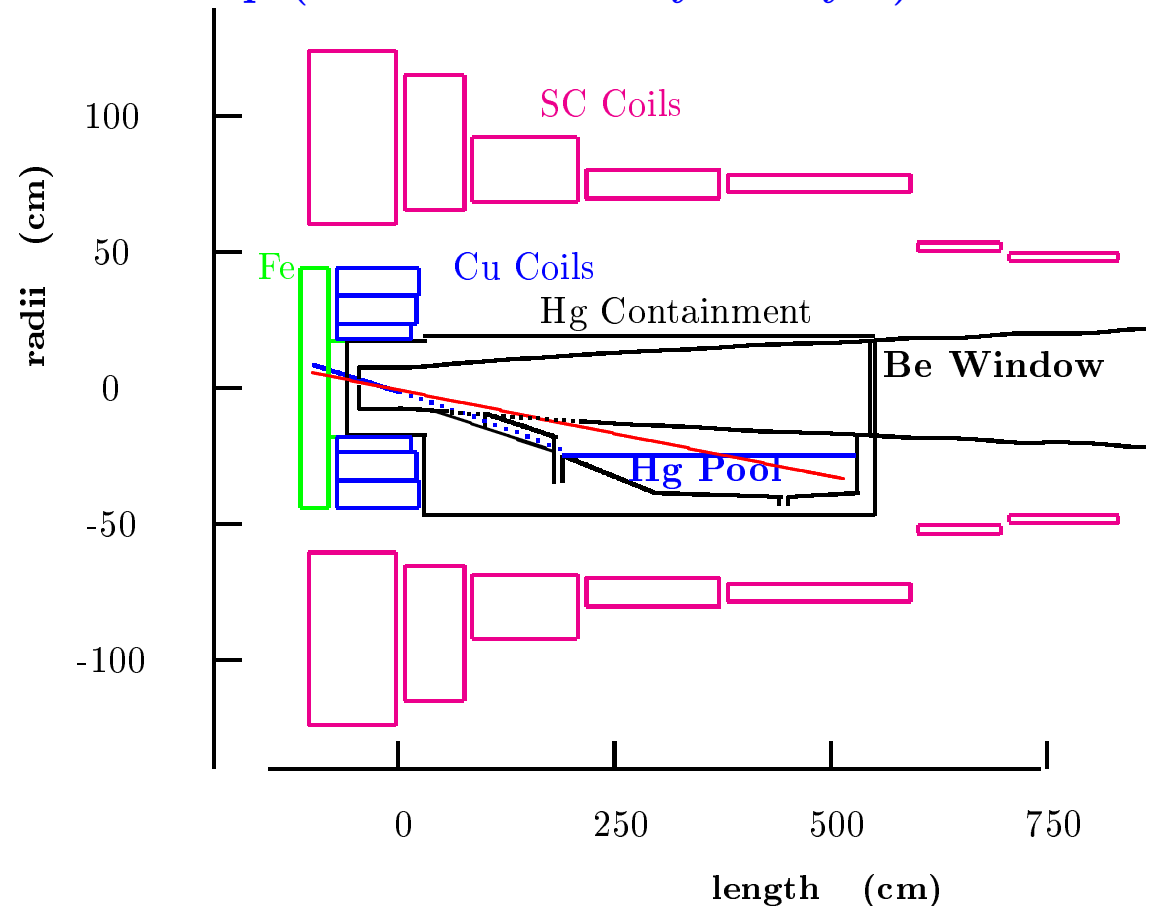

A Neutrino Horn Based on a Solenoid Lens

Point-to-parallel focusing for

$$P_\pi = eBd / (2n + 1)\pi c.$$

⇒ **Narrowband (less background) neutrino beams of energies**

$$E_\nu \approx \frac{P_\pi}{2} = \frac{eBd}{(2n + 1)2\pi c}.$$

⇒ Can study several neutrino oscillation peaks at once,

$$\frac{1.27 M_{23}^2 [\text{eV}^2] L [\text{km}]}{E_\nu [\text{GeV}]} = \frac{(2n + 1)\pi}{2}.$$

(Marciano, hep-ph/0108181)

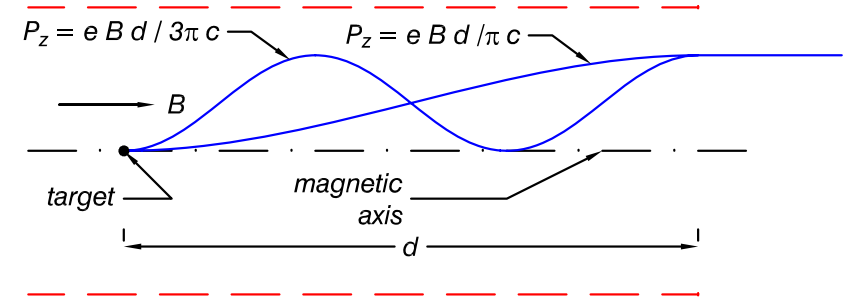
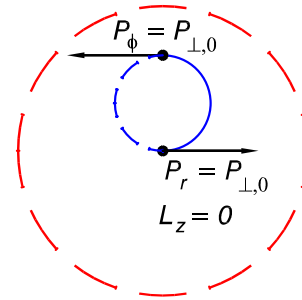

(KTM, physics/0312022)

⇒ Study both ν and $\bar{\nu}$ at the same time.

⇒ **Detector must identify sign of μ and e .**

⇒ **Magnetized liquid argon TPC.**

(astro-ph/0105442).

(H. Kirk and R. Palmer, NuFACT06):

3-m solenoid gives 2 narrow peaks in ν spectrum.

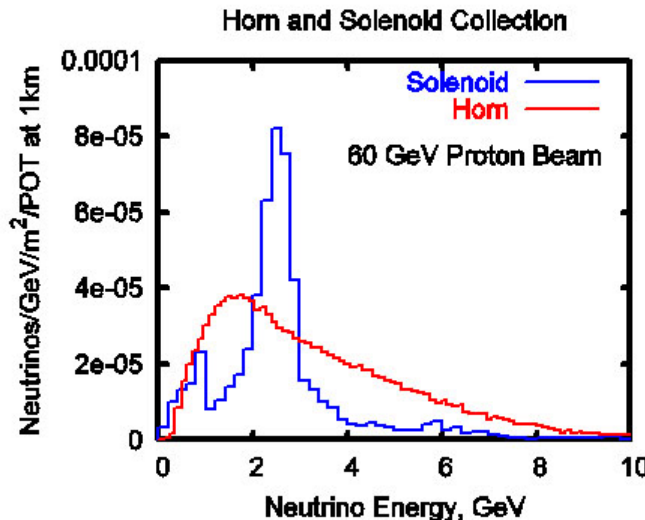

3-30-m solenoid broadens the higher energy peak.

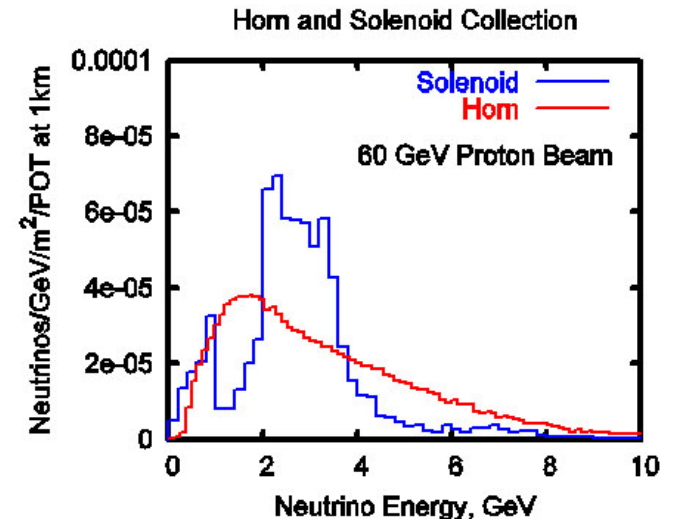



Solid Targets

Thermal Issues for Solid Targets, I

The quest for efficient capture of secondary pions precludes traditional schemes to cool a solid target by a liquid. (Absorption by plumbing; cavitation of liquid.)

A solid, radiation-cooled stationary target in a 4-MW beam will equilibrate at about 2500 C. \Rightarrow Carbon is only candidate for this type of target.

(Carbon target must be in He atmosphere to suppress sublimation.)

A moving band target (Ta, W, ...) could be considered (if capture system is toroidal).

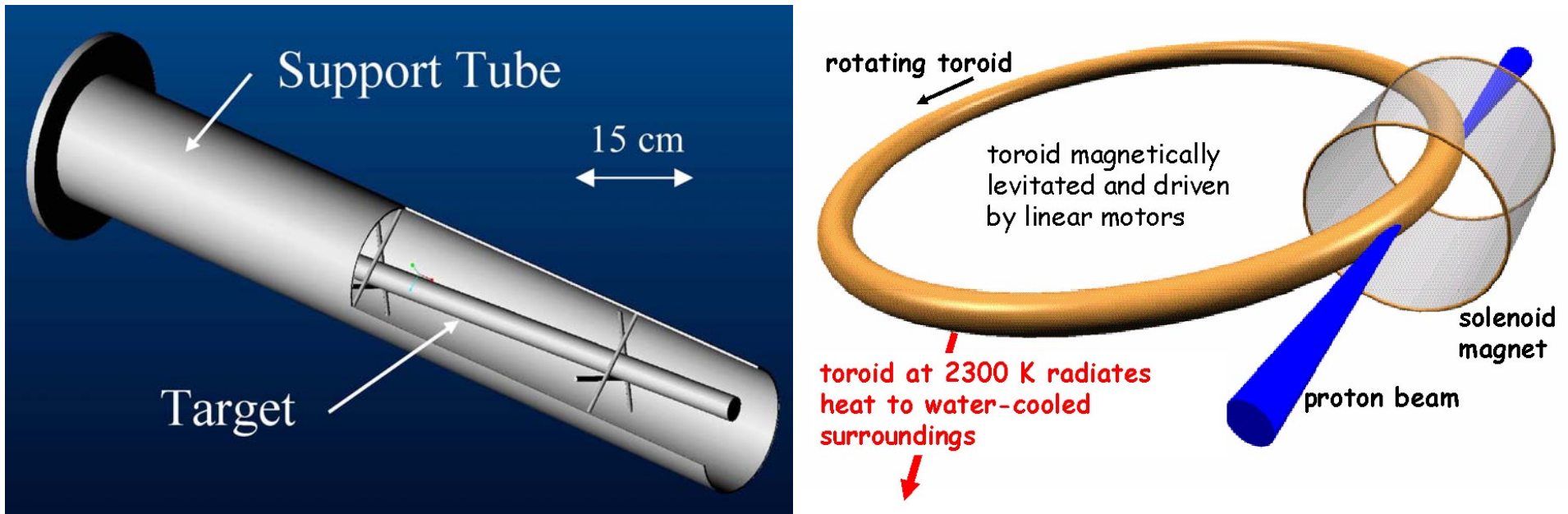

Thermal Issues for Solid Targets, II

When beam pulse length t is less than target radius r divided by speed of sound v_{sound} , beam-induced pressure waves (thermal shock) are a major issue.

Simple model: if U = beam energy deposition in, say, Joules/g, then the instantaneous temperature rise ΔT is given by

$$\Delta T = \frac{U}{C}, \quad \text{where } C = \text{heat capacity in Joules/g/K.}$$

The temperature rise leads to a strain $\Delta r/r$ given by

$$\frac{\Delta r}{r} = \alpha \Delta T = \frac{\alpha U}{C}, \quad \text{where } \alpha = \text{thermal expansion coefficient.}$$

The strain leads to a stress P (= force/area) given by

$$P = E \frac{\Delta r}{r} = \frac{E \alpha U}{C}, \quad \text{where } E = \text{modulus of elasticity.}$$

In many metals, the tensile strength obeys $P \approx 0.002E$, $\alpha \approx 10^{-5}$, and $C \approx 0.3 \text{ J/g/K}$, in which case

$$U_{\text{max}} \approx \frac{PC}{E\alpha} \approx \frac{0.002 \cdot 0.3}{10^{-5}} \approx \mathbf{60 \text{ J/g.}}$$

⇒ Best candidates for solid targets have high strength (Vascomax, Inconel, TiAl6V4) and/or low thermal expansion (Superinvar, Toyota “gum metal”, carbon-carbon composite).

A Carbon Target is Feasible at 1-2 MW Beam Power

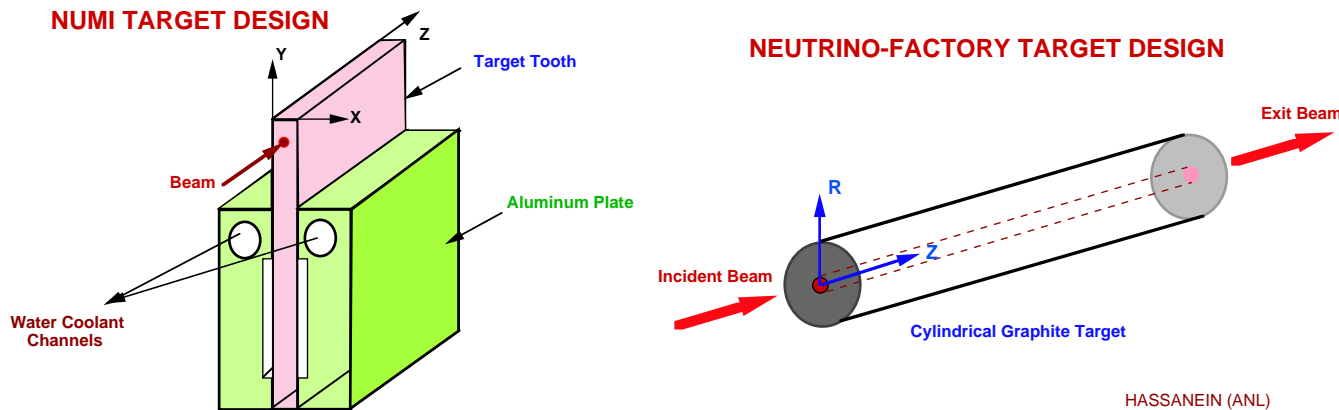

Low energy deposition per gram and low thermal expansion coefficient reduce thermal “shock” in carbon.

Operating temperature $> 2000\text{C}$ if use only radiation cooling.

A carbon target in vacuum would sublime away in 1 day at 4 MW, but sublimation of carbon is negligible in a helium atmosphere.

Radiation damage is limiting factor: ≈ 12 weeks at 1 MW.

⇒ Carbon target is baseline design for most neutrino superbeams.

Useful pion capture increased by compact, high- Z target,
 ⇒ Continued R&D on solid targets.

How Much Beam Power Can a Solid Target Stand?

How many protons are required to deposit 60 J/g in a material?

What is the maximum beam power this material can withstand without cracking, for a 10-GeV beam at 10 Hz with area 0.1 cm².

Ans: If we ignore “showers” in the material, we still have dE/dx ionization loss, of about 1.5 MeV/g/cm².

Now, 1.5 MeV = 2.46×10^{-13} J, so 60 J/g requires a proton beam intensity of $60/(2.4 \times 10^{-13}) = 2.4 \times 10^{14}/\text{cm}^2$.

So, $P_{\text{max}} \approx 10 \text{ Hz} \cdot 10^{10} \text{ eV} \cdot 1.6 \times 10^{-19} \text{ J/eV} \cdot 2.4 \times 10^{14}/\text{cm}^2 \cdot 0.1 \text{ cm}^2 \approx 4 \times 10^5 \text{ J/s} = 0.4 \text{ MW}$.

If solid targets crack under singles pulses of 60 J/g, then safe up to only 0.4 MW beam power!

Empirical evidence is that some materials survive 500-1000 J/g,
 \Rightarrow May survive 4 MW if rep rate $\gtrsim 10$ Hz.

Ni target in FNAL $p\bar{b}$ source:
 “damaged but not failed” for peak energy deposition of 1500 J/g.



Lower Thermal Shock If Lower Thermal Expansion Coefficient

ATJ graphite and a 3-D weave of carbon-carbon fibers instrumented with fiberoptic strain sensors, and exposed to pulses of 4×10^{12} protons @ 24 Gev.

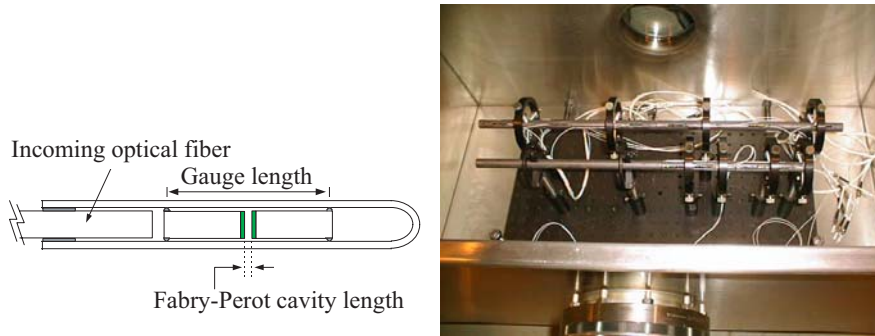

BNL E951 Target Experiment
24 GeV 3.0 e12 proton pulse on Carbon-Carbon and ATJ graphite targets
Recorded strain induced by proton pulse

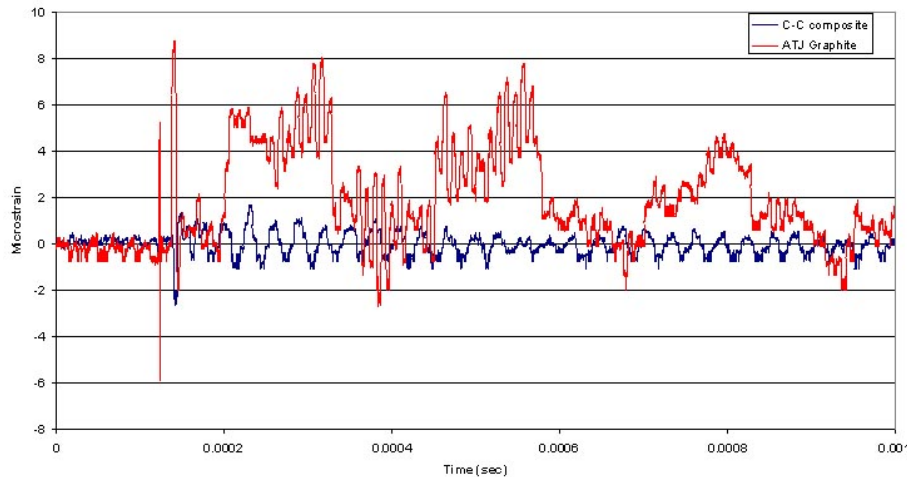

Carbon-carbon composite showed much lower strains than in the ordinary graphite – but readily damaged by radiation!

Thermal expansion coefficient of engineered materials is affected by radiation.

Super-Invar: CTE vs. dose:

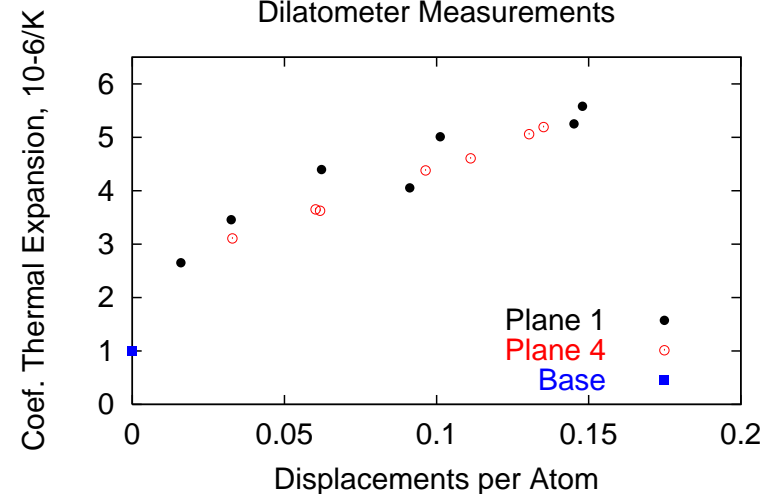

Super-Invar: recovery of the CTE by thermal annealing:

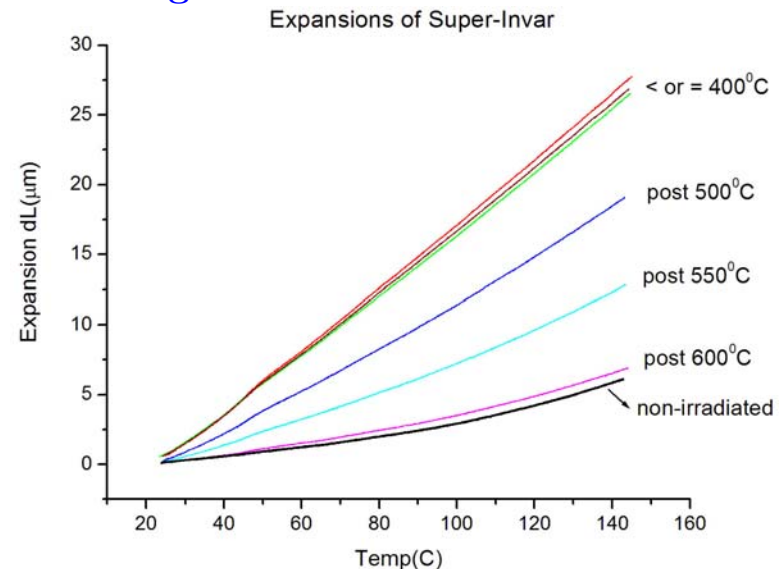

Recent/Ongoing Solid Target Projects

CNGS Target System
 (R. Bruno, NuFact06)
 Up to 7×10^{13} 400-GeV
 protons every 6 s.
 Beam $\sigma = 0.5$ mm.
 5 interchangeable
 graphite targets.
 Designed for 0.75 MW.

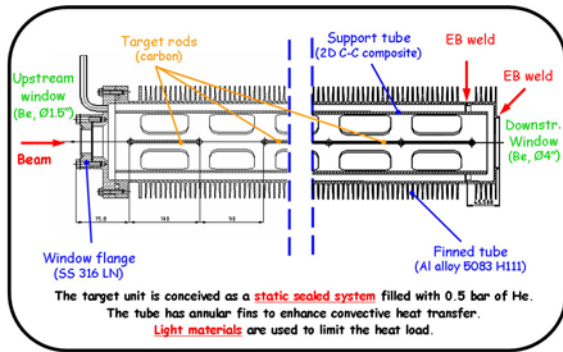

JPARC ν Horn Target
 (Y. Hayato, NuFact06)
 Up to 4×10^{14} 50-GeV
 protons every 4 s.
 Beam $\sigma = 4$ mm.
 Designed for 0.75 MW.
 He gas cooling.

- Co-axial 2 layer cooling pipe: Graphite / Ti-6Al-4V, Helium cooling

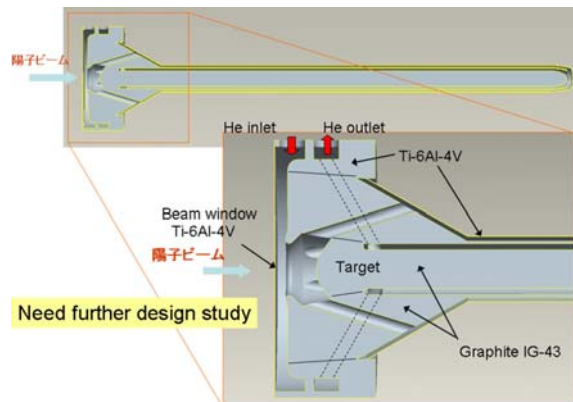
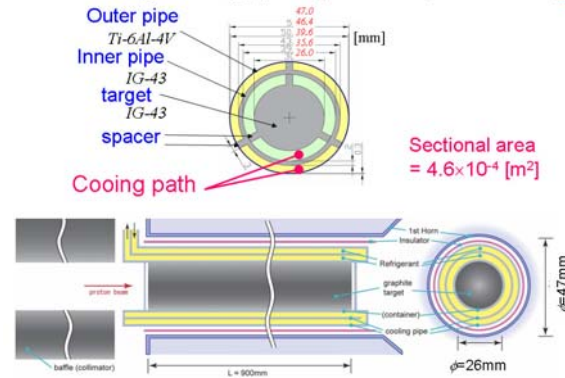

Pulsed-Current Studies
 of Ta & W Wires at RAL
 (R. Bennett *et al.*)

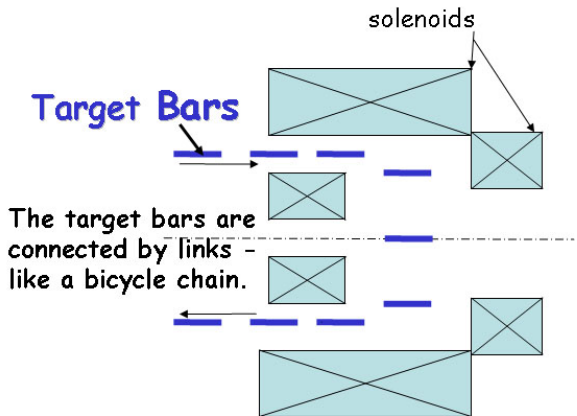
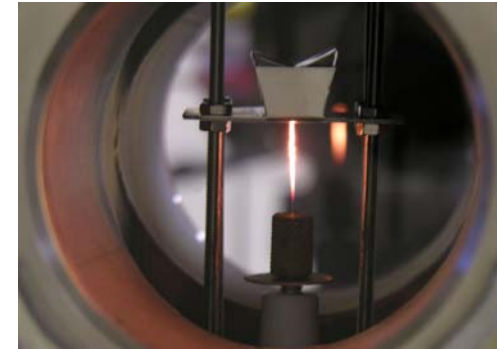
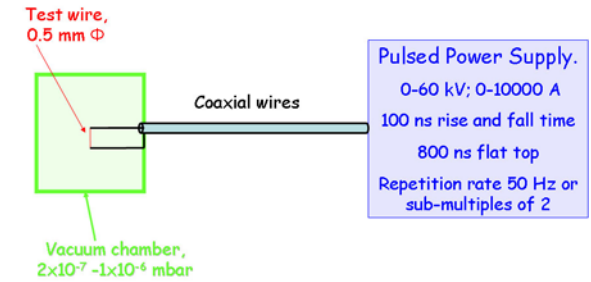

Liquid Jet Targets

A. Calder, Paris (1937):



Now at Fundació Joan Miró, Barcelona

Beam-Induced Cavitation in Liquids Can Break Pipes

Hg in a pipe (BINP):

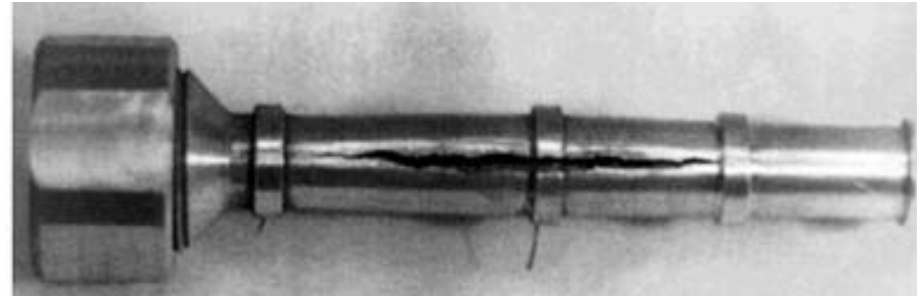

ISOLDE:



Cavitation pitting of SS wall surrounding Hg target after 100 pulses (SNS):

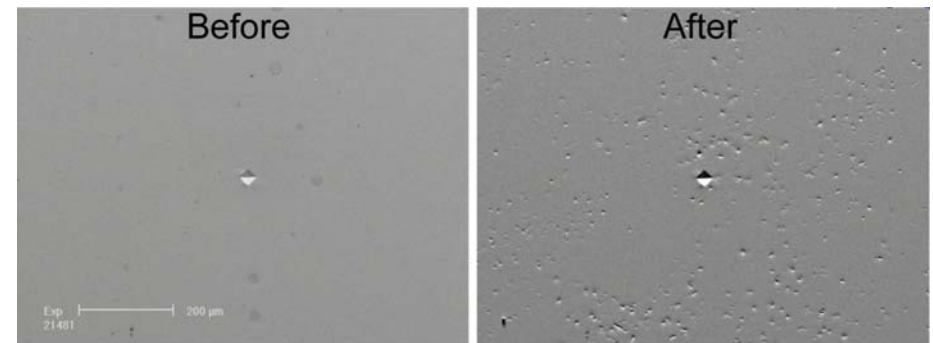

TL - High Power Target
Specimen # 29754
Equivalent SNS Power Level = 2.5

Water jacket of NuMI target developed a leak after \approx 1 month. Likely due to beam-induced cavitation.

Ceramic drainpipe of water cooling system of CNGS horn failed after 2 days operation at high beam power. (Not directly a beam-induced failure.)

\Rightarrow Use free liquid jet if possible.

How Snapping Shrimp Snap: Through Cavitating Bubbles

M. Versluis, Science 289, 2114 (2000).

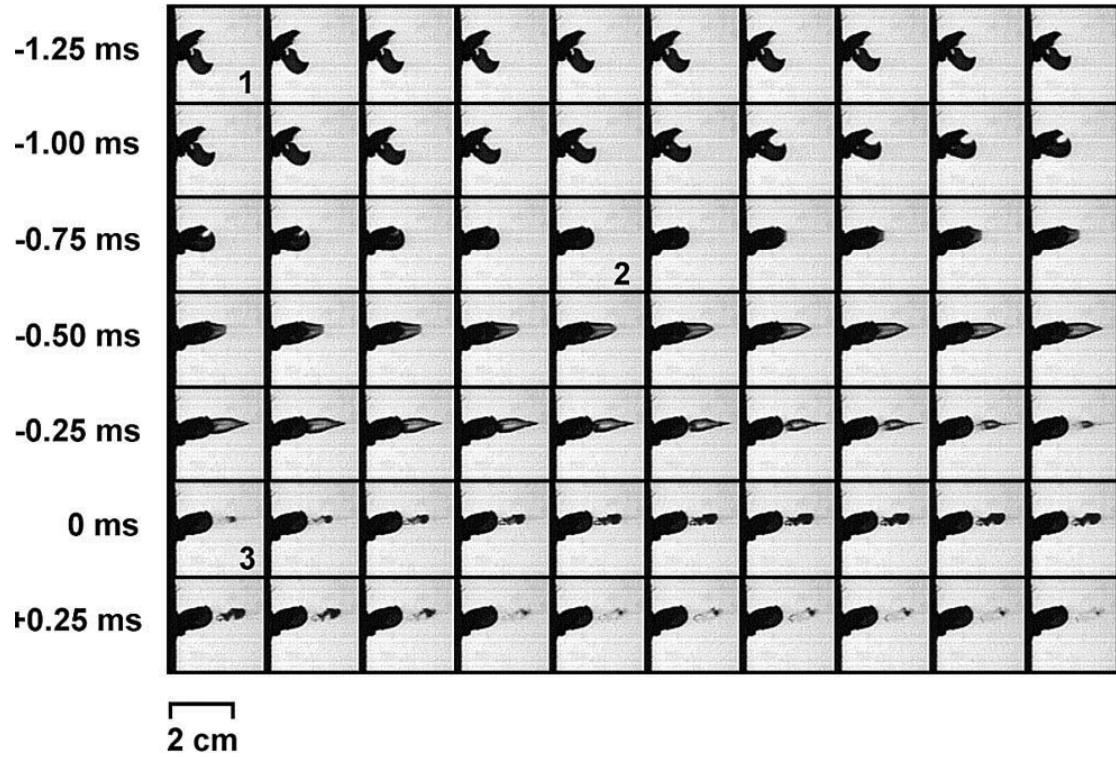
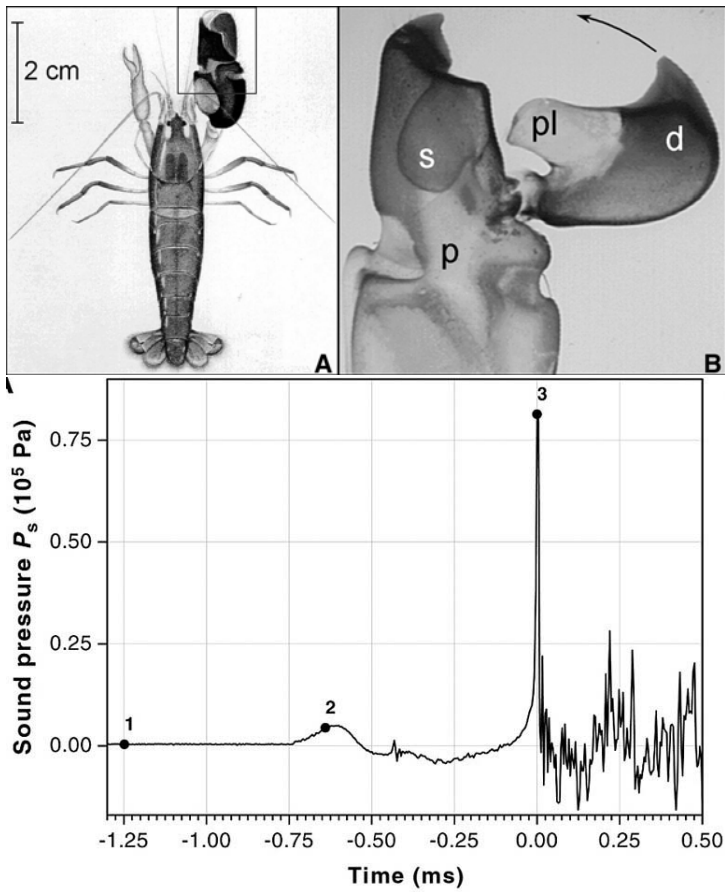

Beam-Induced Effects on a Free Liquid Jet

Beam energy deposition may disperse the jet.

FRONTIER simulation predicts breakup via filamentation on mm scale:

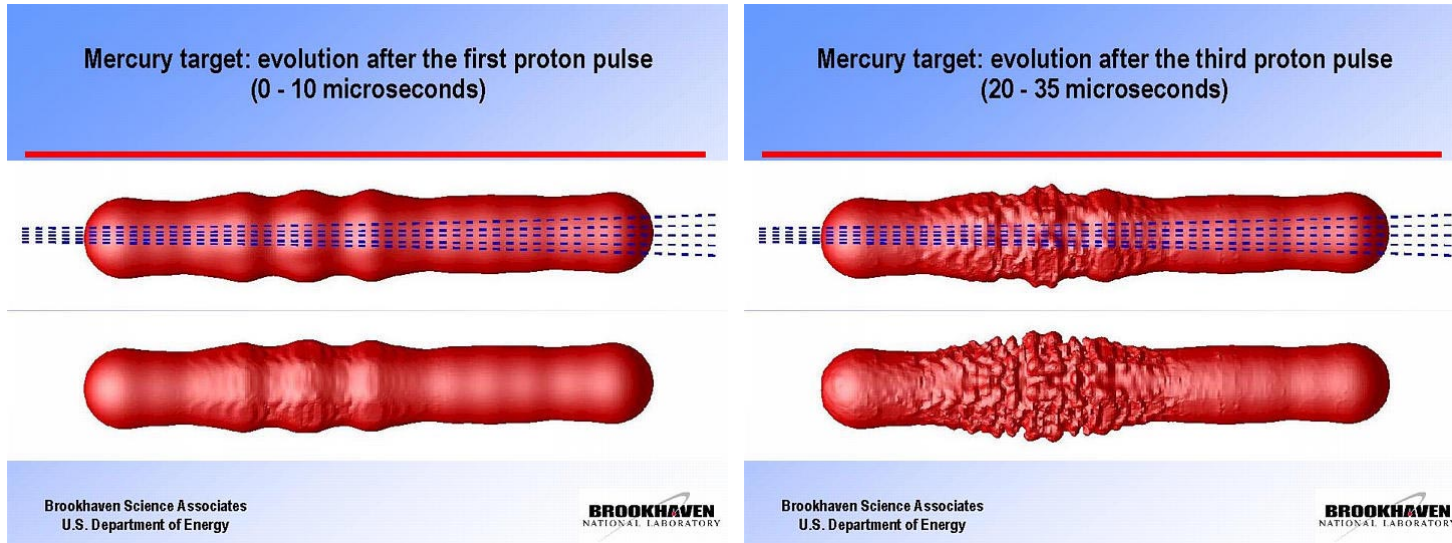

Laser-induced breakup of a water jet:
(J. Lettry, CERN)

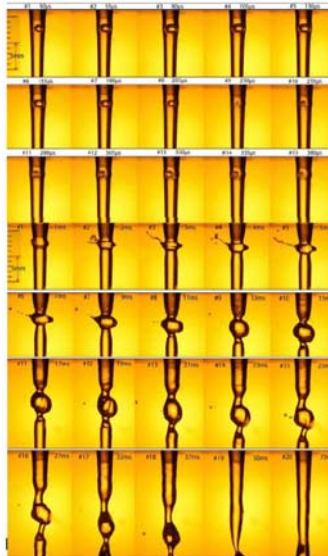

Water jet ripples generated by a 8 mJ Laser cavitation bubble



Passive Mercury Target Tests (BNL-CERN, 2001-2002)

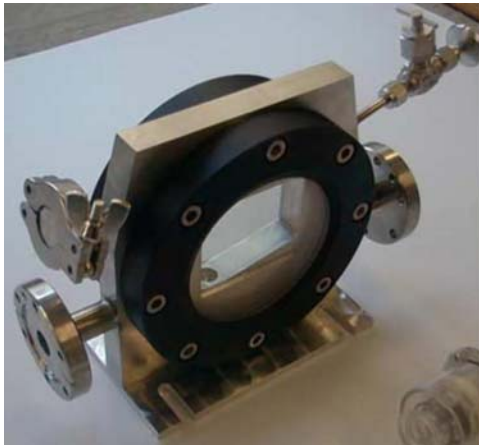

Exposures of 25 μ s at
 $t = 0, 0.5, 1.6, 3.4$ msec,
 $\Rightarrow v_{\text{splash}} \approx 20 - 40$ m/s:

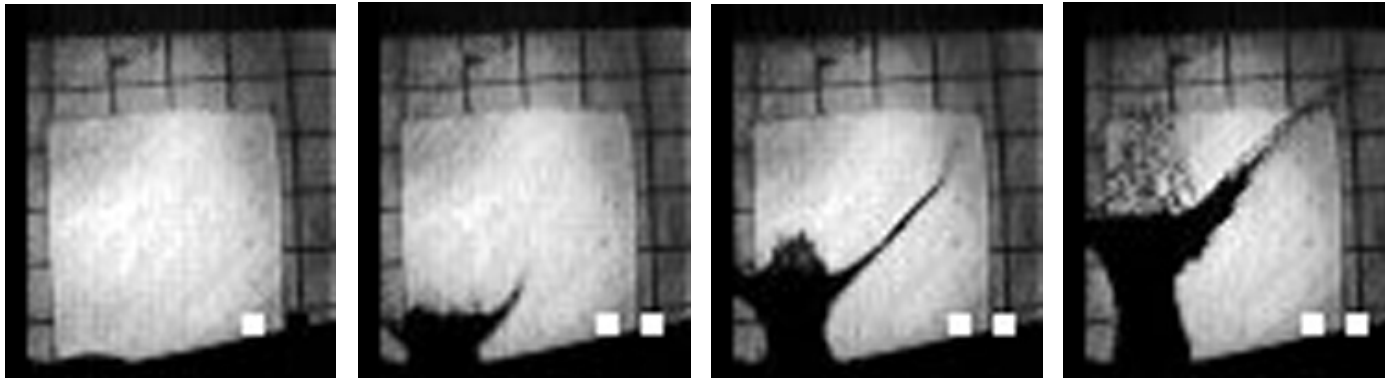

Two pulses of ≈ 250 ns give larger dispersal velocity only if separated by $< 3 \mu$ s.

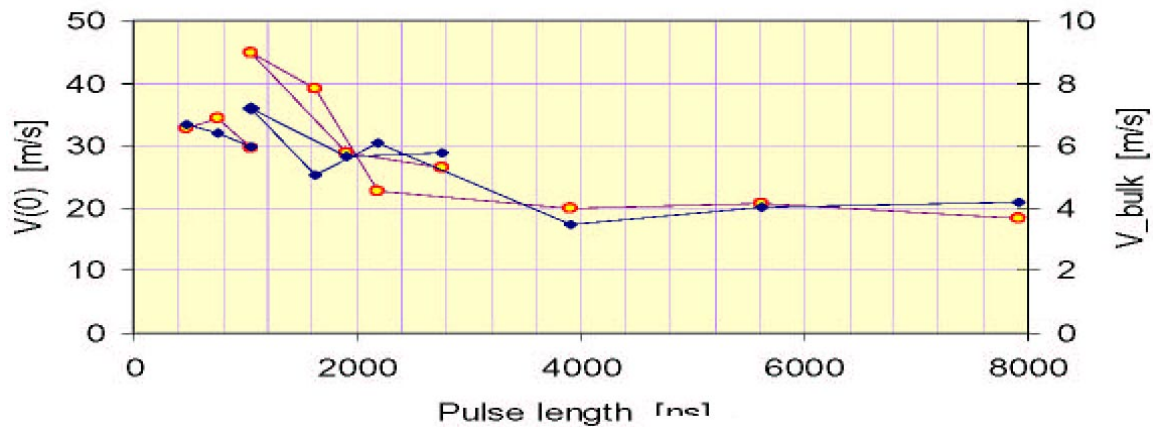

Studies of Proton Beam + Mercury Jet

1-cm-diameter Hg jet in $2e12$ protons at $t = 0, 0.75, 2, 7, 18$ ms.

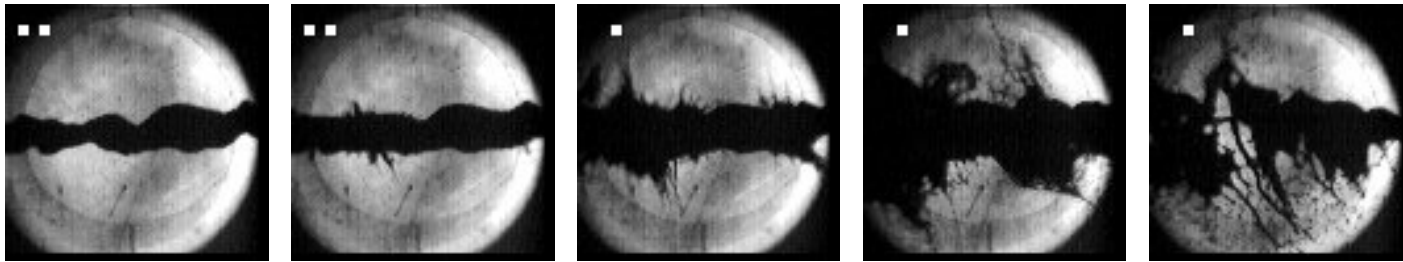
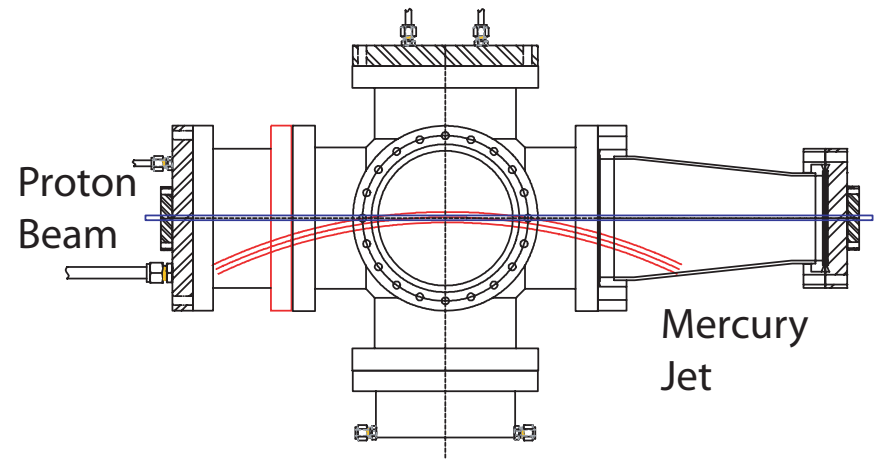

Model:
$$v_{\text{dispersal}} = \frac{\Delta r}{\Delta t} = \frac{r\alpha\Delta T}{r/v_{\text{sound}}} = \frac{\alpha U}{C} v_{\text{sound}} \approx 50 \text{ m/s for } U \approx 100 \text{ J/g.}$$

Data: $v_{\text{dispersal}} \approx 10 \text{ m/s for } U \approx 25 \text{ J/g.}$

$v_{\text{dispersal}}$ appears to scale with proton intensity.

The dispersal is not destructive.

Filaments appear only $\approx 40 \mu\text{s}$ after beam,

\Rightarrow After several bounces of waves, OR v_{sound} very low.

Hydrodynamics of Liquid Jet Targets

- **Diameter $d = 1$ cm.**
- **Velocity $v = 20$ m/s.**
- **The volume flow rate of mercury in the jet is**

$$\begin{aligned} \text{Flow Rate} = vA &= 2000 \text{ cm/s} \cdot \frac{\pi}{4} d^2 = 1571 \text{ cm}^3/\text{s} = 1.57 \text{ l/s} = 0.412 \text{ gallon/s} \\ &= 94.2 \text{ l/min} = 24.7 \text{ gpm.} \end{aligned} \quad (1)$$

- **The power in the jet (associated with its kinetic energy) is**

$$\text{Power} = \frac{1}{2} \rho \cdot \text{Flow Rate} \cdot v^2 = \frac{13.6 \times 10^3}{2} \cdot 0.00157 \cdot (20)^2 = 4270 \text{ W} = 5.73 \text{ hp.} \quad (2)$$

- **To produce the 20-m/s jet into air/vacuum out of a nozzle requires a pressure**

$$\text{Pressure} = \frac{1}{2} \rho v^2 = 27.2 \text{ atm} = 410 \text{ psi,} \quad (3)$$

IF no dissipation of energy.

- **The mercury jet flow is turbulent: the viscosity is $\mu_{\text{Hg}} = 1.5$ cP (kinematic viscosity $\eta = \mu/\rho = 0.0011$ cm²/s), so the Reynolds number is**

$$\mathcal{R} = \frac{\rho dv}{\mu} = \frac{dv}{\eta} = 1.8 \times 10^6. \quad (4)$$

- **The surface tension of mercury is $\tau = 465$ dyne/cm (water = 73), \Rightarrow**

$$\text{Weber number, } \mathcal{W} = \frac{\rho dv^2}{\tau} = 115,000. \quad (5)$$

Nozzle Lore

Leach & Walker (1966):

Hg jet for Neutrino Factory:
 $v = 20 \text{ m/s}$, $d = 1 \text{ cm}$,
 \Rightarrow Turbulent flow.

Lore:

- Should be able to make a 1-cm-diameter Hg jet go 1-2 m before breakup.
- Area of feed should be $\gtrsim 10\times$ area of nozzle.
- $\approx 15^\circ$ nozzle taper is good.
- Nozzle tip should be straight, with $\approx 3:1$ aspect ratio.
- High-speed jets will have a halo of spray around a denser core.
- Low/zero surrounding gas pressure is better.

McCarthy & Molloy (1974):

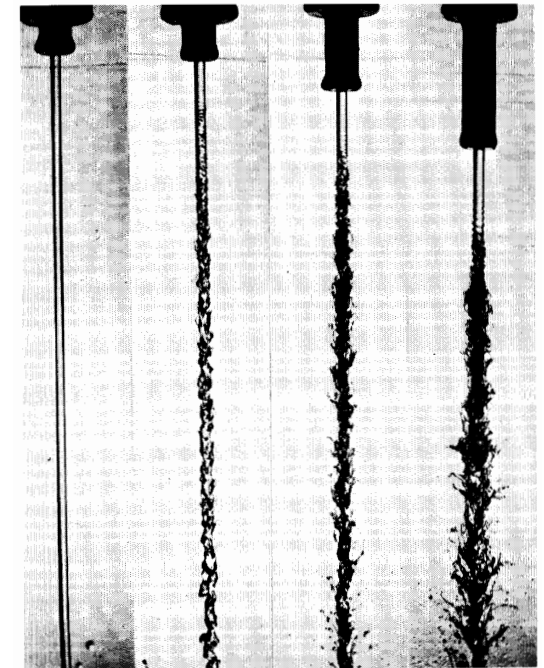
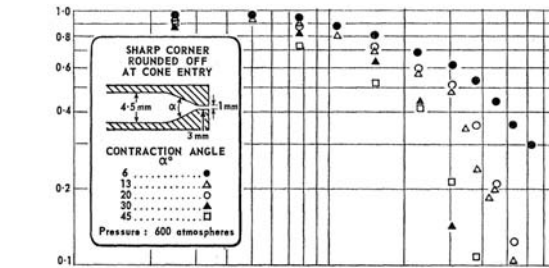
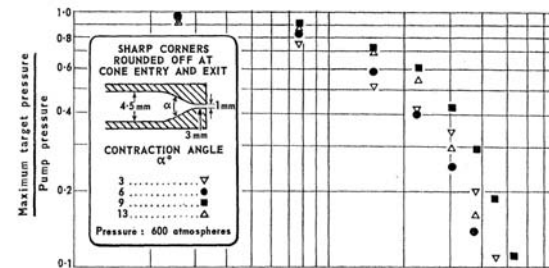

Fig. 5. Effect of nozzle design on the stability of glycerol-water jets.

Jet viscosity 11 cP
 Jet velocity 20 m s^{-1} (approx.)
 Nozzle diameter 2.54 mm
 Jet Reynolds no. 4750
 Jet Ohnesorge no. 0.026
 Exposure $30 \mu\text{sec}$
 Nozzle aspect ratio $AR = L/d$ (see Fig. 7) = 0, 1, 5, 10 L to R.



(a) Rounded inlet corners



(b) Rounded corners at both ends of contraction

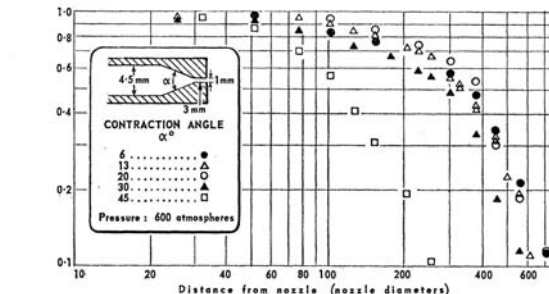

(c) Sharp corners

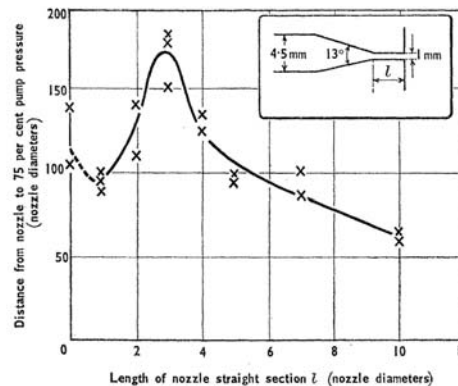

MUTAC REVIEW, APR 18, 2007

Leach & Walker:

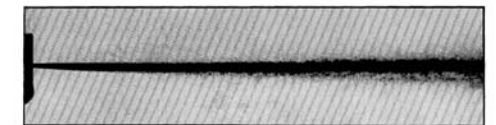

(d) Spark source; parallel transmitted light ($\frac{1}{2} \mu\text{s}$ exposure); pressure 130 atm.

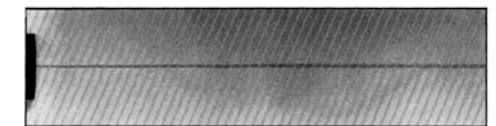

(e) X-ray source (5 min exposure); pressure 130 atm.

Magnetic Issues for Liquid Metal Jet Targets

Conducting materials that move through nonuniform magnetic field experience eddy-current effects, \Rightarrow Forces on entering or leaving a solenoid (but not at its center).

\Rightarrow Free jet of radius r cannot pass through a horizontal solenoid of diameter D unless

$$v > \frac{3\pi\sigma r^2 B_0^2}{32\rho D} \approx 6 \left[\frac{r}{1 \text{ cm}} \right]^2 \text{ m/s,} \quad \text{for Hg or Pb-Bi jet, } D = 20 \text{ cm, } B_0 = 20 \text{ T.}$$

50-Hz rep rate requires $v = 20$ m/s for new target each pulse, so no problem for baseline design with $r = 0.5$ cm. The associated eddy-current heating is negligible.

[Small droplets pass even more easily, and can fall vertically with no retardation.]

A liquid jet experiences a quadrupole shape distortion if tilted with respect to the solenoid axis. This is mitigated by the upstream iron plug that makes the field more uniform.

Magnetic damping of surface-tension waves (Rayleigh instability) observed in CERN-Grenoble tests (2002).

The beam-induced dispersal will be partially damped also (Samulyak).

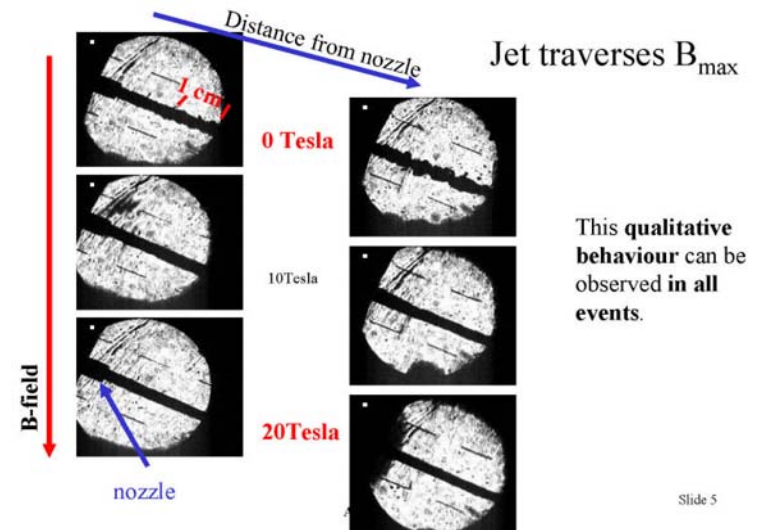

Slide 5

Computational Magnetohydrodynamics (R. Samulyak, J. Du)

Use an equation of state that supports negative pressures, but gives way to cavitation.

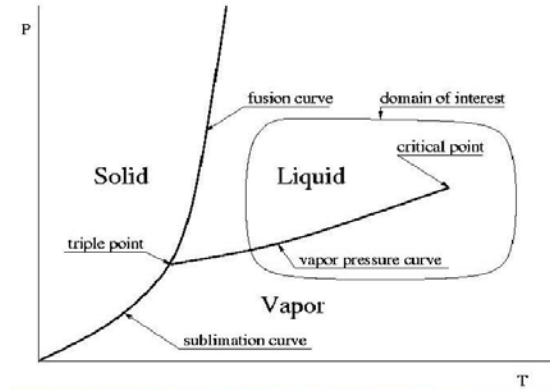

Critical point : $T_c = 1750\text{K}$, $P_c = 172\text{MPa}$, $V_c = 43\text{cm}^3\text{mol}^{-1}$

Thimble splash at 0.24, 0.48, 0.61, 1.01 μs

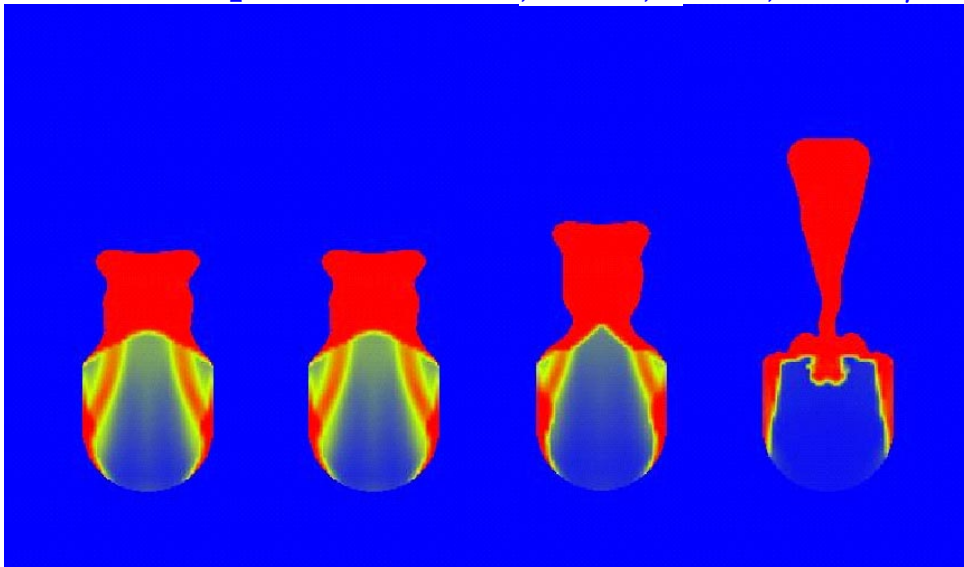

Magnetic damping of beam-induced filamentation:

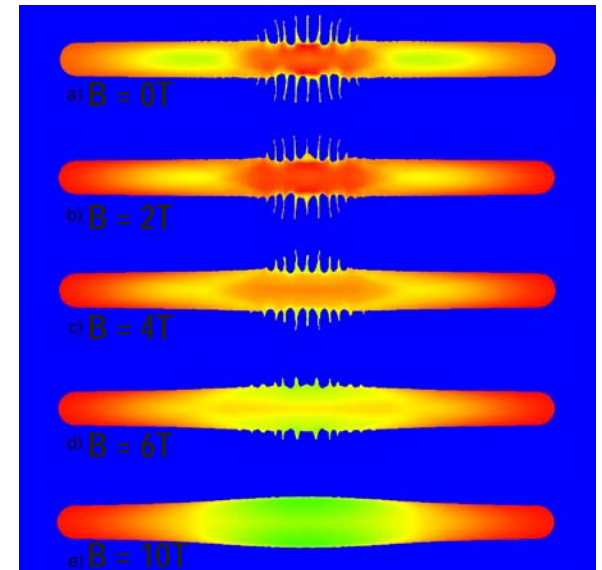

The Shape of a Mercury Jet under a Non-uniform Magnetic Field

S. Oshima *et al.*, JSME Int. J. 30, 437 (1987).

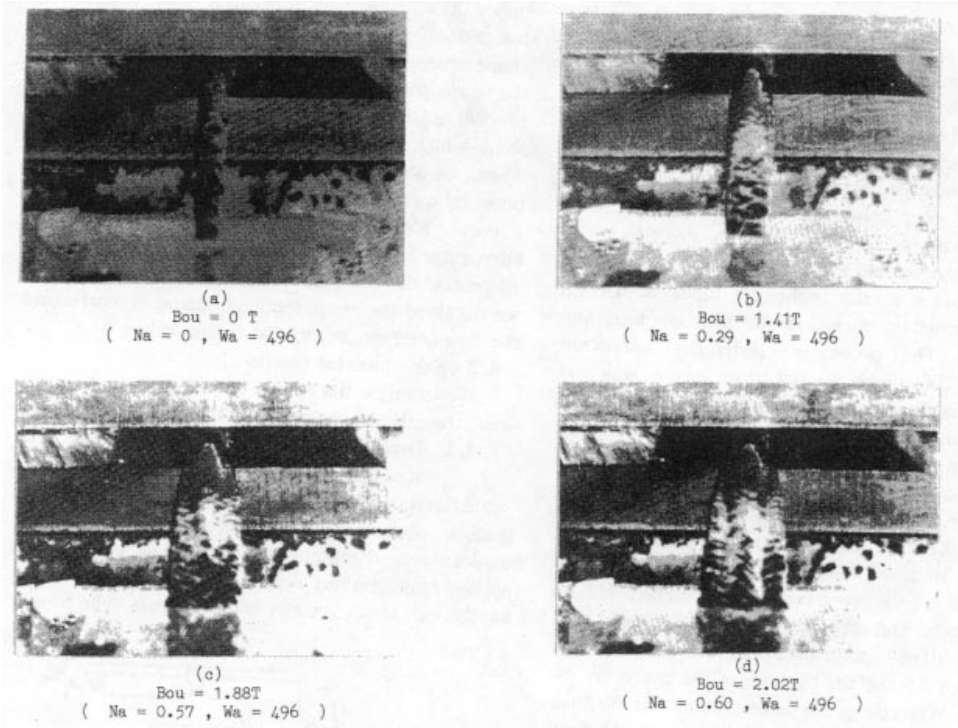

Fig. 9 Photographs of the jet for various applied magnetic field strengths

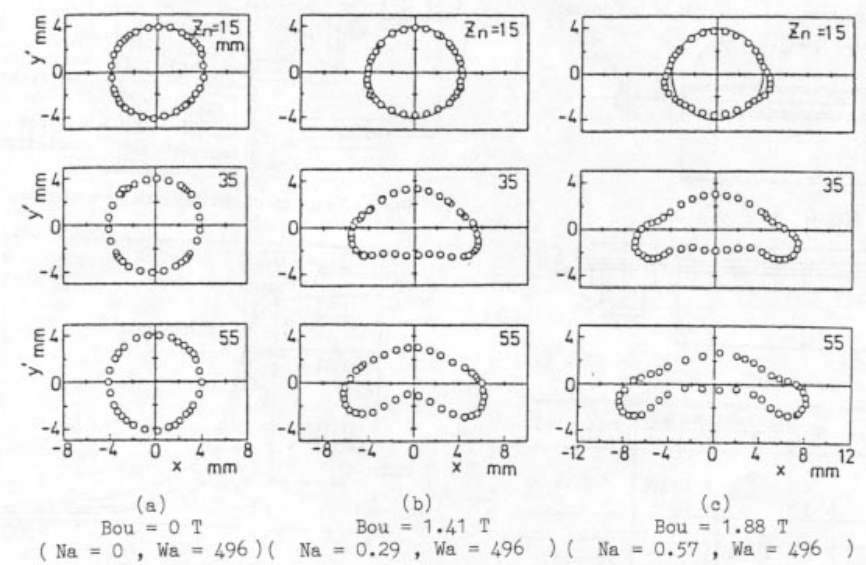
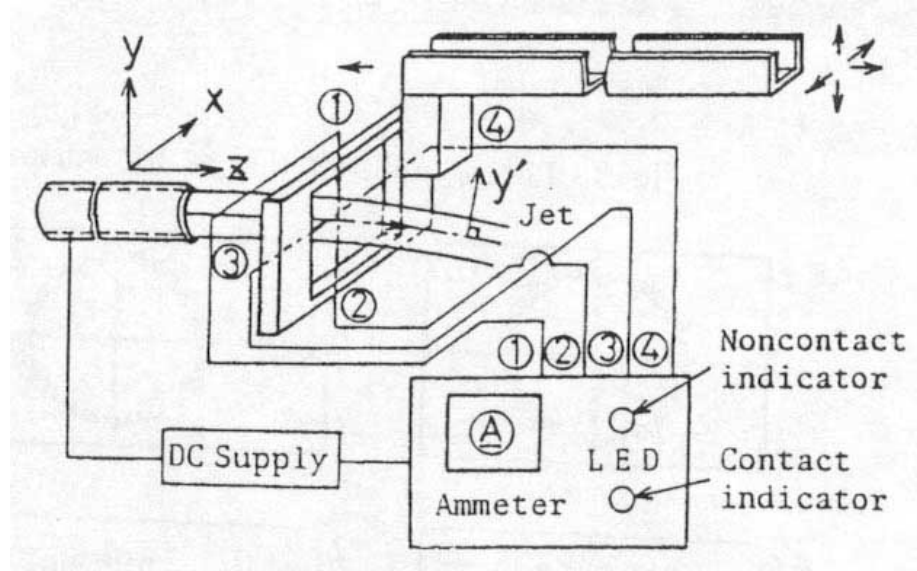
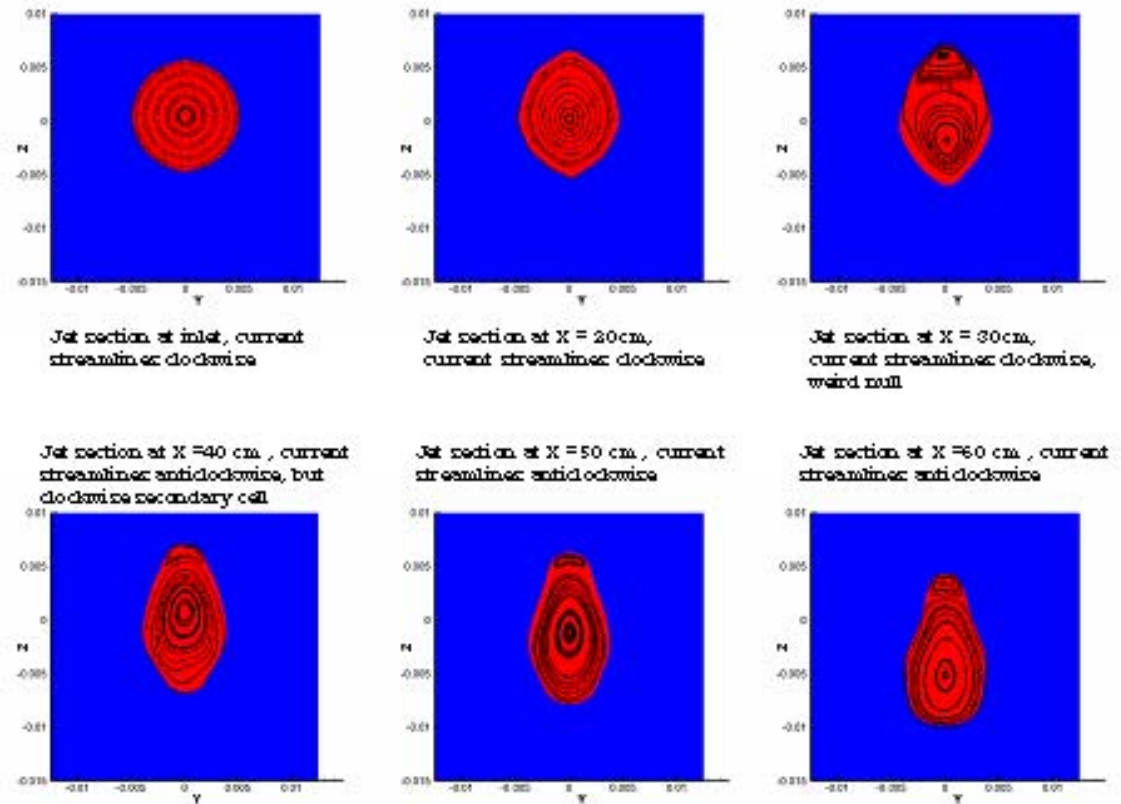
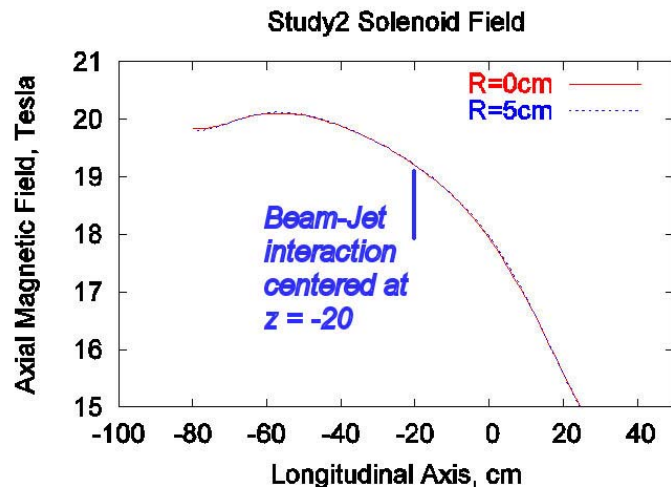

Fig. 10 Cross-sectional shape of the jet obtained by spot a electrode probe

Simulations of Shape Distortion

Incompressible code with free liquid surface confirms predictions of shape distortion of a liquid mercury jet that crosses magnetic field lines. (N. Morley, M. Narula; HIMAG).

Mitigate with good uniformity of magnetic field:



20-T Capture Magnet System (ν Factory Study 2)

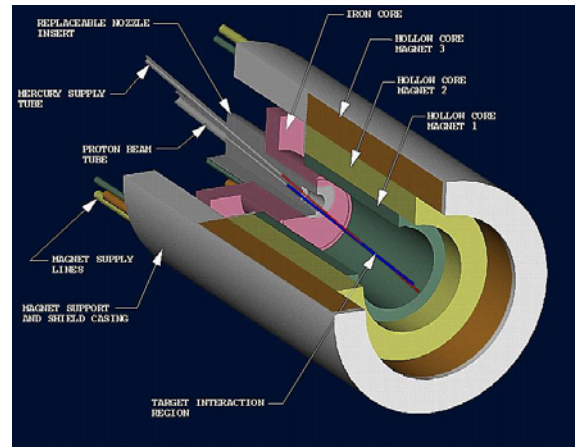

Inner, hollow-conductor copper coils generate 6 T @ 12 MW:

Bitter-coil option less costly, but marginally feasible.

Outer, superconducting coils generate 14 T @ 600 MJ:

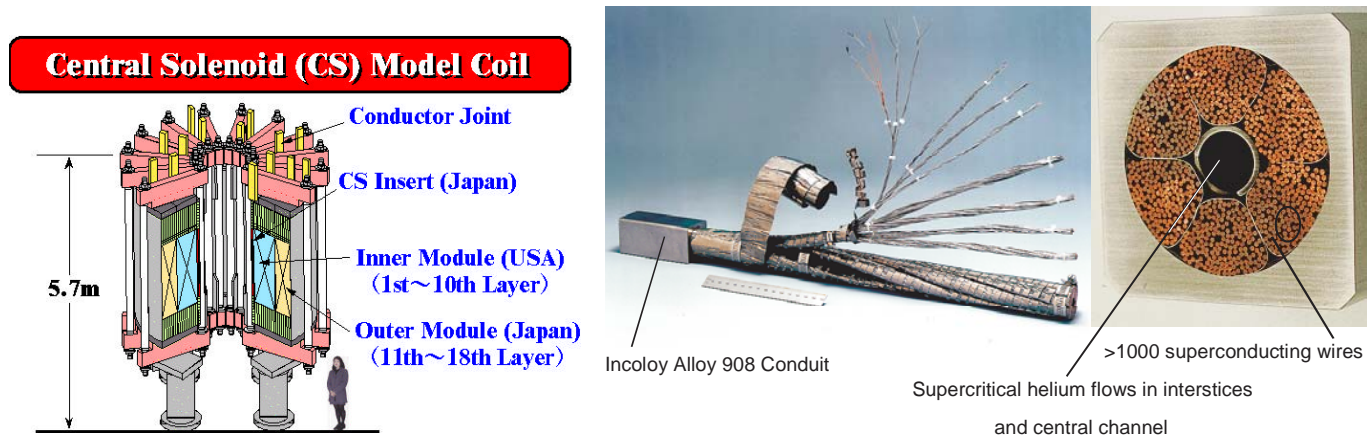

Cable-in-conduit construction similar to ITER central solenoid.

Both coils shielded by tungsten-carbide/water.

Target System Support Facility

Extensive shielding; remote handling capability.

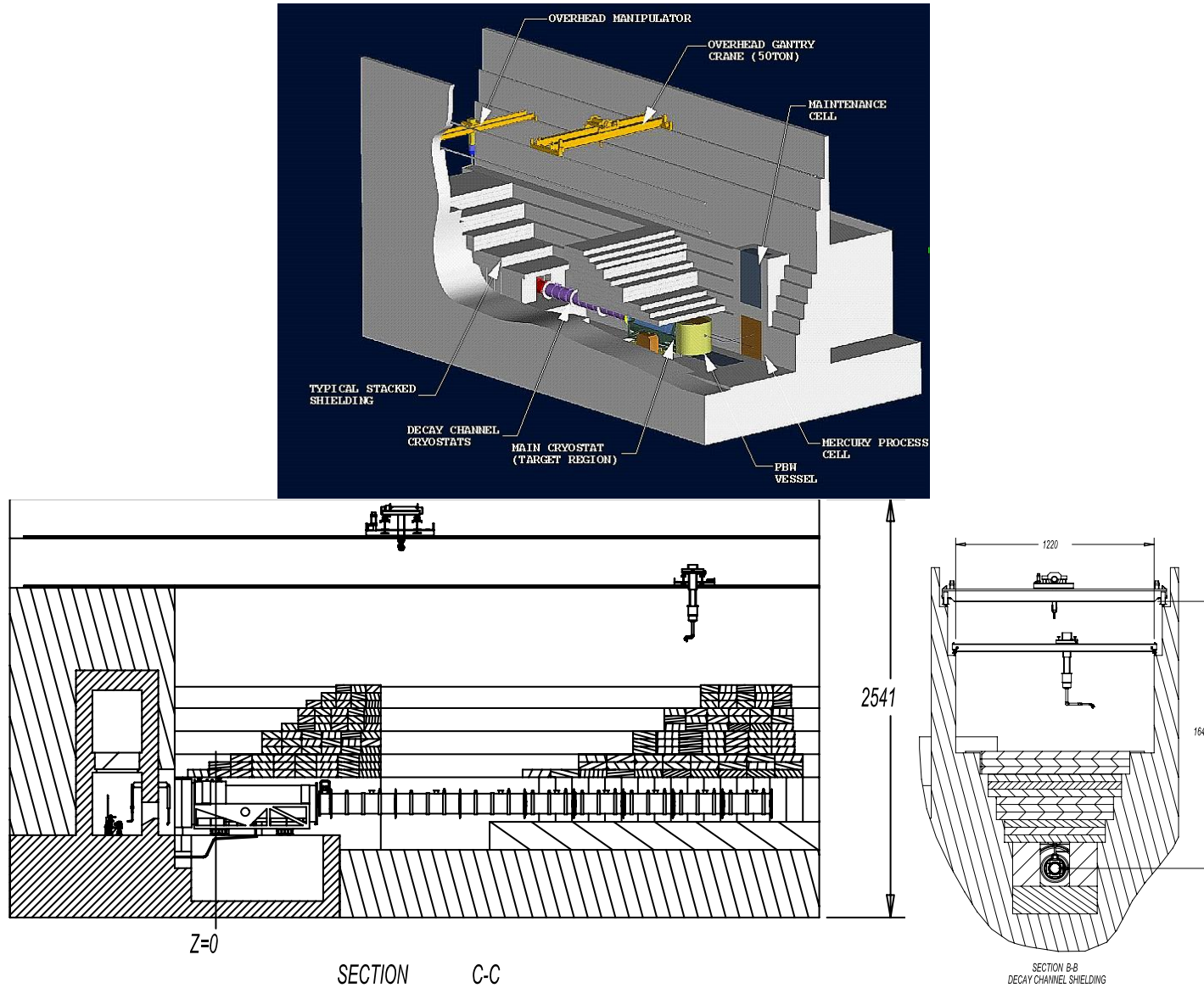

Lifetime of Components in the High Radiation Environment

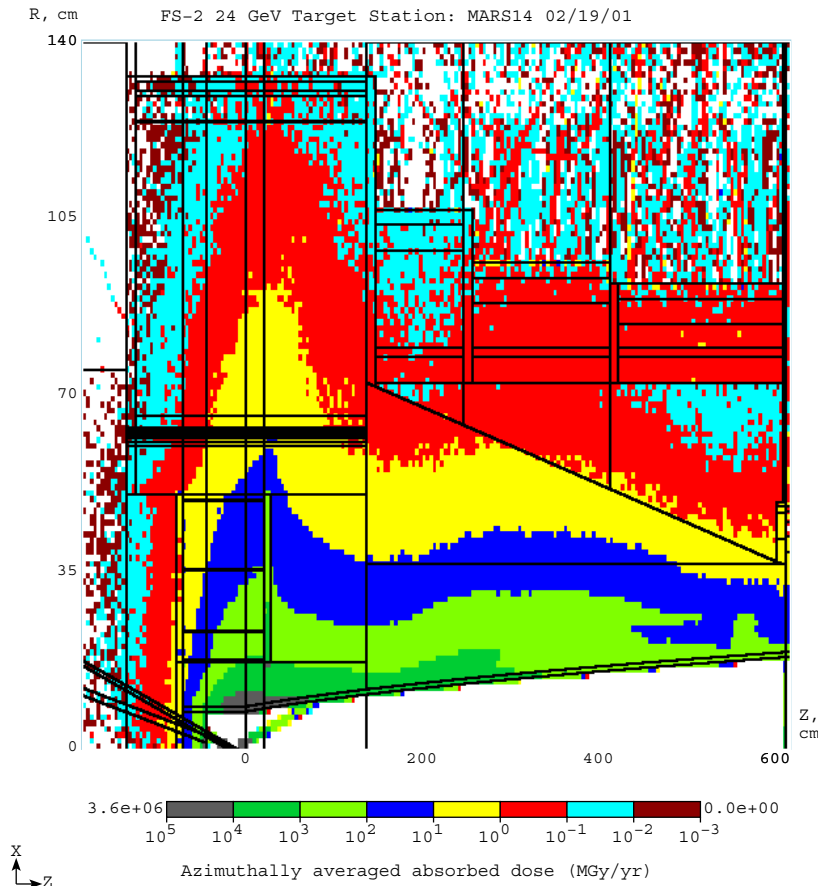

Some components must be replaceable.

Component	Radius (cm)	Dose/yr (Grays/ 2×10^7 s)	Max allowed Dose (Grays)	1 MW Life (years)	4 MW life (years)
Inner shielding	7.5	5×10^{10}	10^{12}	20	5
Hg containment	18	10^9	10^{11}	100	25
Hollow conductor coil	18	10^9	10^{11}	100	25
Superconducting coil	65	5×10^6	10^8	20	5



Summary

What Have We Learned?

- Solid targets are viable in pulsed proton beams of up to 1-2 MW.
- Engineered materials with low coefficients of thermal expansion are desirable, but require further qualification for use at high radiation dose.
- A mercury jet appears to behave well in a proton beam at zero magnetic field, and in a high magnetic field without proton beam.

Issues for Further Targetry R&D

- Continue numerical simulations of MHD + beam-induced effects (J. Du).
- For solid targets, study radiation damage – and issues of heat removal from solid metal targets (carbon/carbon, Toyota Ti alloy, bands, chains, *etc.*) (N. Simos, R. Bennett).
- Proof-of-Principle test of an intense proton beam with a mercury jet inside a high-field magnet (CERN MERIT experiment, H. Kirk, V. Graves, H.-J. Park).
 1. MHD effects in a prototype target configuration.
 2. Magnetic damping of mercury-jet dispersal.
 3. Beam-induced damage to jet nozzle – in the magnetic field.
- Pb-Bi liquid metal targets: solid at room temp, less subject to boiling.

CERN nToF11 Experiment (MERIT)

- The MERIT experiment is a proof-of-principle demonstration of a free mercury jet target for a 4-megawatt proton beam, contained in a 15-T solenoid for maximal collection of soft secondary pions.
- MERIT = MERcury Intense Target.
- Key parameters:
 - 24-GeV Proton beam pulses, up to 16) bunches/pulse, up to 2.5×10^{12} p /bunch.
 - σ_r of proton bunch = 1.2 mm, proton beam axis at 67 mrad to magnet axis.
 - Mercury jet of 1 cm diameter, $v = 20$ m/s, jet axis at 33 mrad to magnet axis.
 - \Rightarrow Each proton intercepts the Hg jet over 30 cm = 2 interaction lengths.
- Every beam pulse is a separate experiment.
 - ~ 100 Beam pulses in total.
 - Vary bunch intensity, bunch spacing, number of bunches.
 - Vary magnetic field strength.
 - Vary beam-jet alignment, beam spot size.

CERN nToF11 Experiment (MERIT)

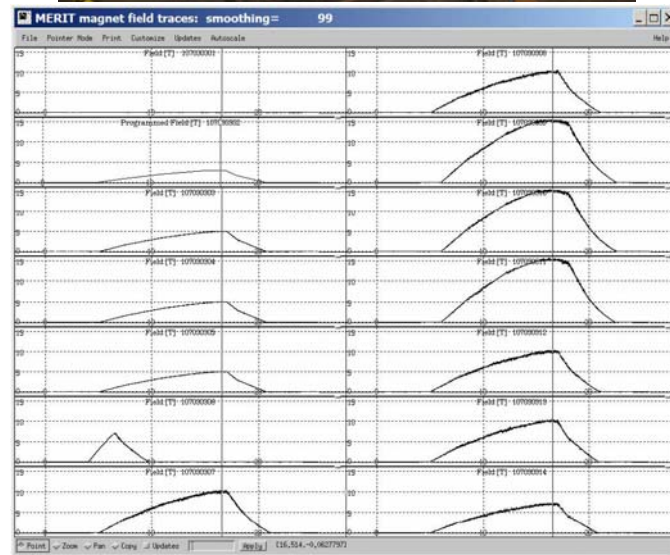
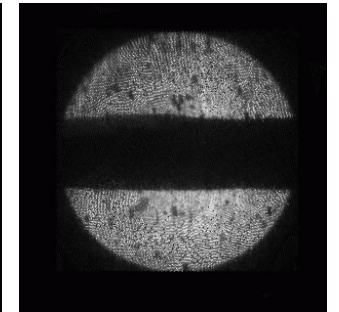
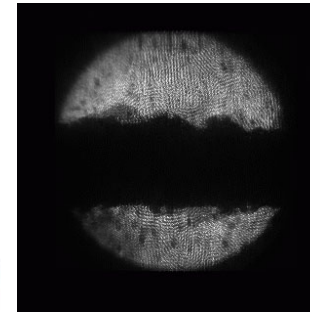
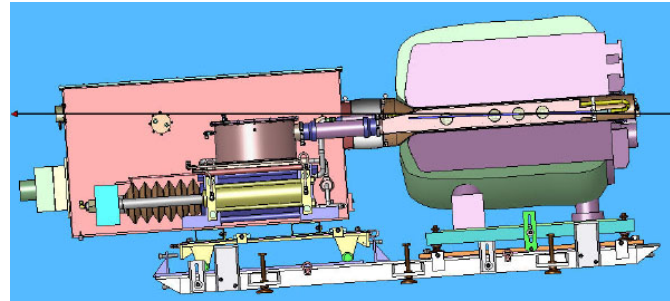
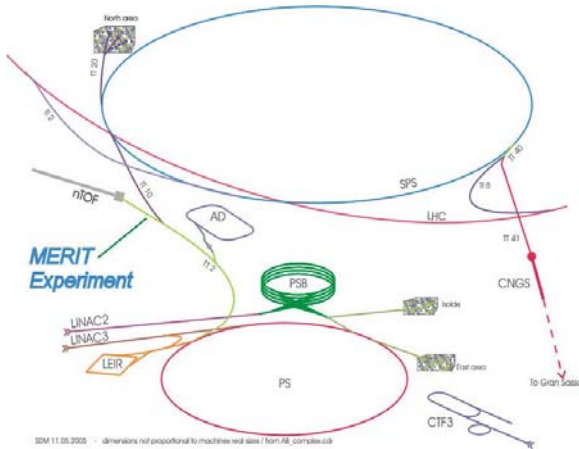

High-Power Target Workshops Sponsored by the NFMCC

- **Ronkonkoma (2003)**
<http://www.cap.bnl.gov/mumu/conf/target-030908/agenda.xhtml>
- **ORNL (2005)**
<http://www.cap.bnl.gov/mumu/conf/target-051010/agenda.html>
- **PSI (Sept 10-14, 2007)**
<http://asq.web.psi.ch/hptrgts/index.html>

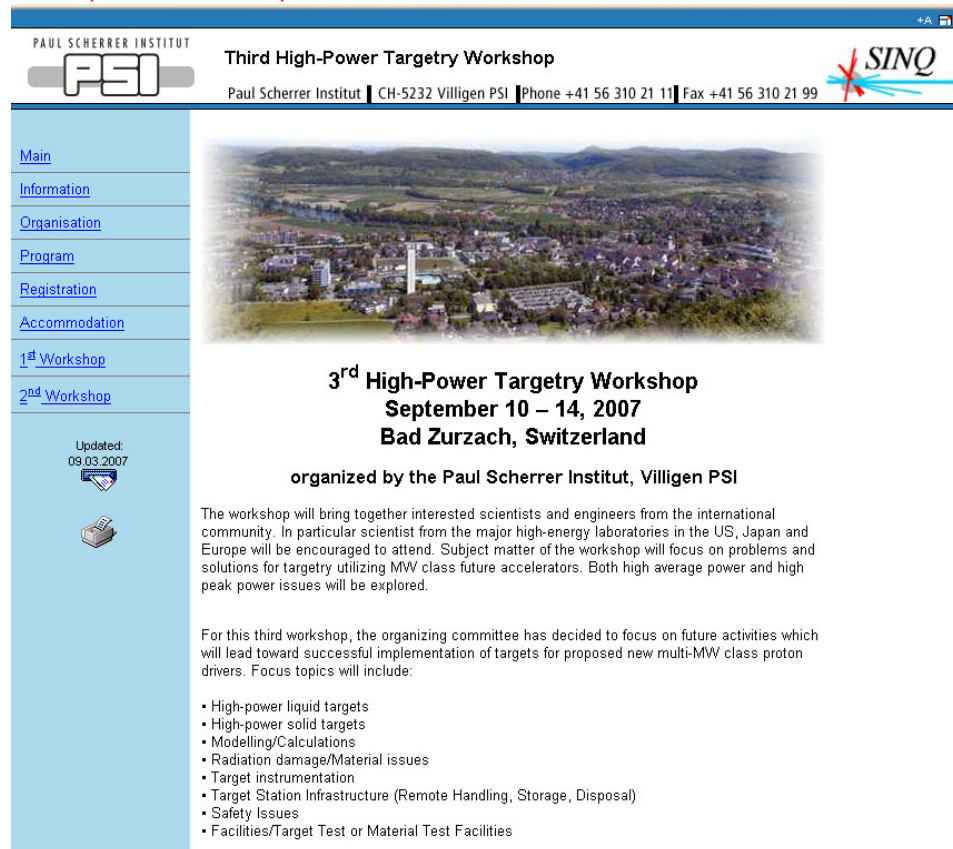

PAUL SCHERRER INSTITUT
PSI
 Paul Scherrer Institut | CH-5232 Villigen PSI | Phone +41 56 310 21 11 | Fax +41 56 310 21 99

Third High-Power Targetry Workshop

SINO

[Main](#)
[Information](#)
[Organisation](#)
[Program](#)
[Registration](#)
[Accommodation](#)
[1st Workshop](#)
[2nd Workshop](#)

Updated: 09.03.2007

3rd High-Power Targetry Workshop
September 10 – 14, 2007
Bad Zurzach, Switzerland

organized by the Paul Scherrer Institut, Villigen PSI

The workshop will bring together interested scientists and engineers from the international community. In particular scientist from the major high-energy laboratories in the US, Japan and Europe will be encouraged to attend. Subject matter of the workshop will focus on problems and solutions for targetry utilizing MW class future accelerators. Both high average power and high peak power issues will be explored.

For this third workshop, the organizing committee has decided to focus on future activities which will lead toward successful implementation of targets for proposed new multi-MW class proton drivers. Focus topics will include:

- High-power liquid targets
- High-power solid targets
- Modelling/Calculations
- Radiation damage/Material issues
- Target instrumentation
- Target Station Infrastructure (Remote Handling, Storage, Disposal)
- Safety Issues
- Facilities/Target Test or Material Test Facilities