

High-Power Targets for Superbeams and Neutrino Factories

(and Muon Colliders)

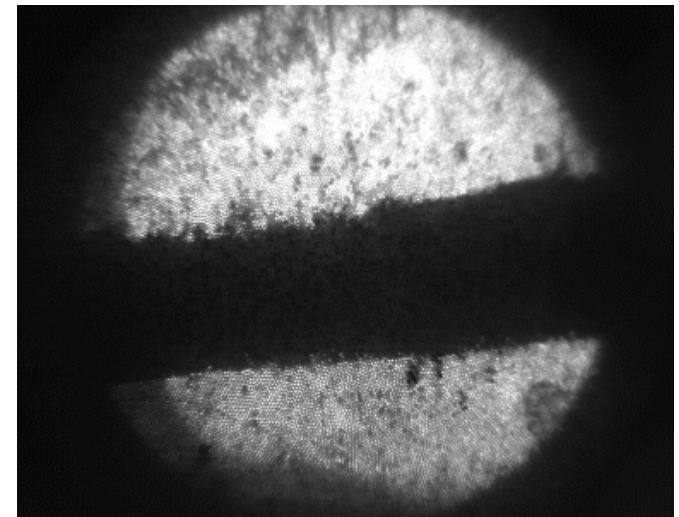
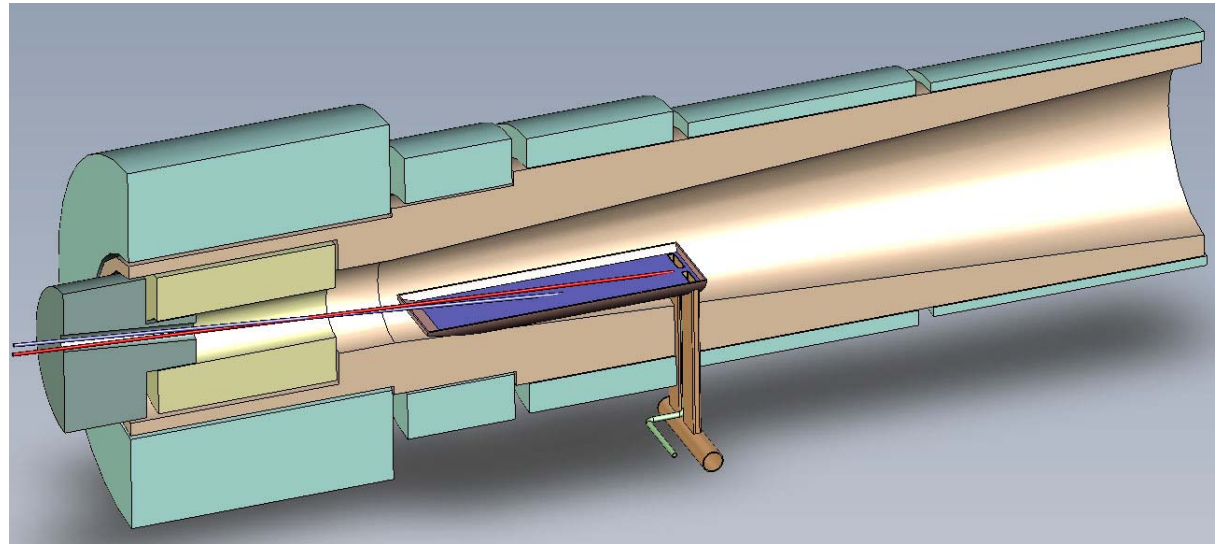
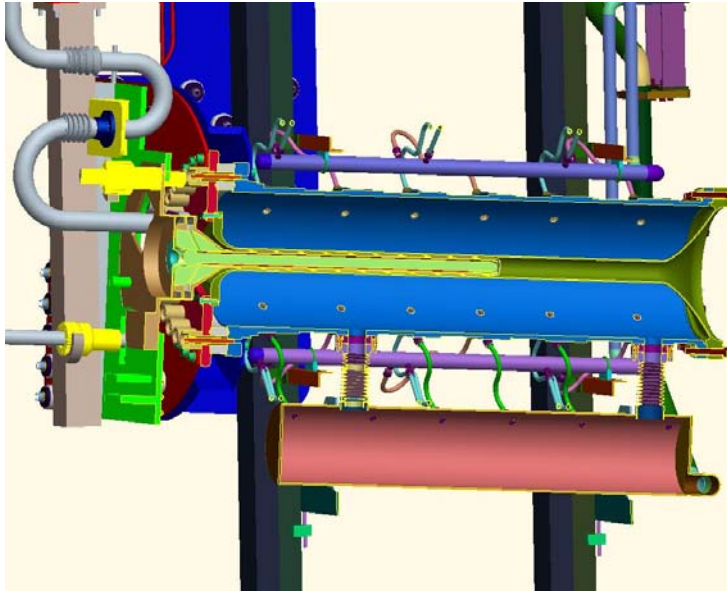

K.T. McDonald
Princeton U.

NuFact08

Valencia, July 3, 2008

Targetry Web Page:

<http://puhep1.princeton.edu/mumu/target/>



Topics Covered (as per NuFact08 Organizers)

Can solid target vs. liquid target survive Superbeam and/or Neutrino Factory beam structure at 2-4 MW?

What additional experimental results are needed to make a choice of Superbeam and Neutrino Factory target?

Presentation:

Introduction

Comments

51 backup slides for discussion



K. McDonald

NuFact08

3 July 2008



The Context

• **Physics:** Nature presents us with the opportunity to explore the richness of the mixing of massive neutrinos using neutrino beams: Mass hierarchy, $\sin^2 \theta_{13}$, CP violation.

• **Neutrino Beams:**

- Superbeam neutrinos from $\pi^\pm \rightarrow \mu^\pm \nu_\mu (\bar{\nu}_\mu)$ (Pions from $pA \rightarrow \pi^\pm X$.)
- **Factory neutrinos** from $\mu^\pm \rightarrow e^\pm \bar{\nu}_\mu \nu_e (\nu_\mu \bar{\nu}_e)$ (**Muons** from $\pi^\pm \rightarrow \mu^\pm \nu_\mu (\bar{\nu}_\mu)$.)
- β -beam neutrinos from ${}^6\text{He} \rightarrow {}^6\text{Li} e^- \bar{\nu}_e$, ${}^{18}\text{Ne} \rightarrow {}^{18}\text{F} e^+ \nu_e$ (not discussed here).

• **Detectors:** Cheapest large detectors are calorimeters with no magnetic field.

⇒ Cheapest to study $\nu_\mu \rightarrow \nu_e$ oscillations with a sign-selected source.

⇒ Long time to study both neutrino and antineutrino oscillations.

Alternatives to permit simultaneous studies of neutrinos and antineutrinos:

- Magnetized iron calorimeter with Neutrino Factory (μ^\pm only).
- Magnetized liquid argon detector with Superbeam and/or Neutrino Factory.

(Only magnetized fine-grain detector {LAr, TAsD, ...} can distinguish e^\pm .)

(Neutrino Factory needs magnetized detector even if sign-selected beam.)

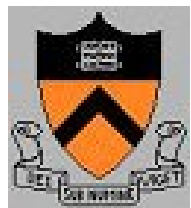

Targetry

The exciting results from atmospheric, solar and reactor neutrino programs (Super-K, SNO, Borexino, KamLAND, ...) reinforce the opportunity for neutrino physics with intense accelerator neutrino beams, where targetry is a major challenge.

Targetry = the task of producing and capturing π 's and μ 's from proton interactions with a nuclear target.

At a muon collider the key parameter is luminosity: $\mathcal{L} = \frac{N_1 N_2 f}{A} \text{s}^{-1} \text{cm}^{-2}$,

\Rightarrow Gain as square of source strength (targetry) [but small beam area (cooling) is also critical].

At a neutrino superbeam and a neutrino factory the key parameter is neutrino flux,

\Rightarrow Source strength (targetry) is of pre-eminent concern.

[Beam cooling important mainly to be sure the beam fits in the pipe.]

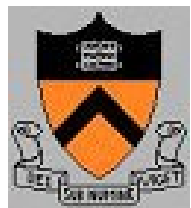

The Target is Pivotal between a Proton Driver and ν or μ Beams

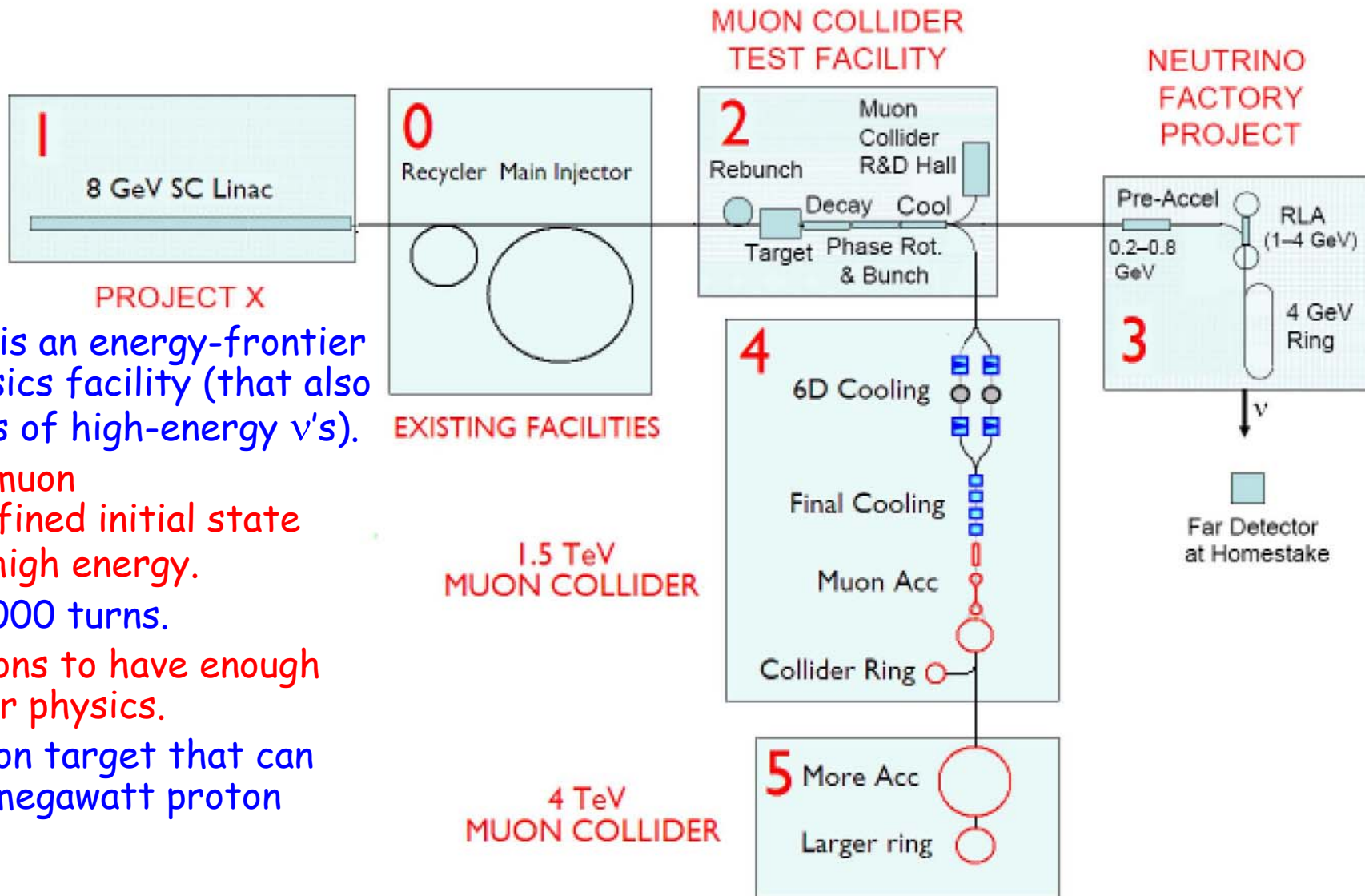

A Muon Collider is an energy-frontier particle-physics facility (that also produces lots of high-energy ν 's).

Higher mass of muon
 \Rightarrow Better defined initial state than e^+e^- at high energy.

A muon lives ≈ 1000 turns.

Need lots of muons to have enough luminosity for physics.

Need a production target that can survive multimegawatt proton beams.

High-Power Targets Essential for Many Future Facilities

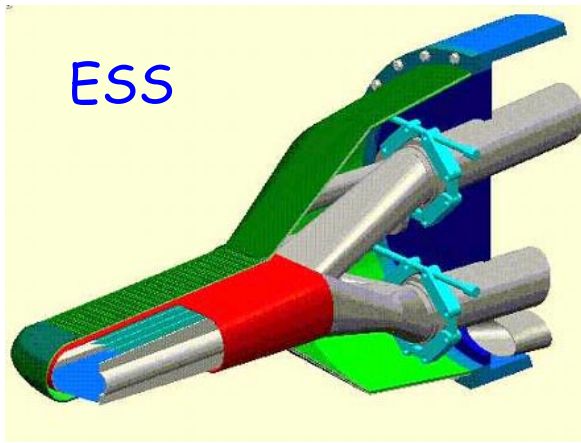

ESS

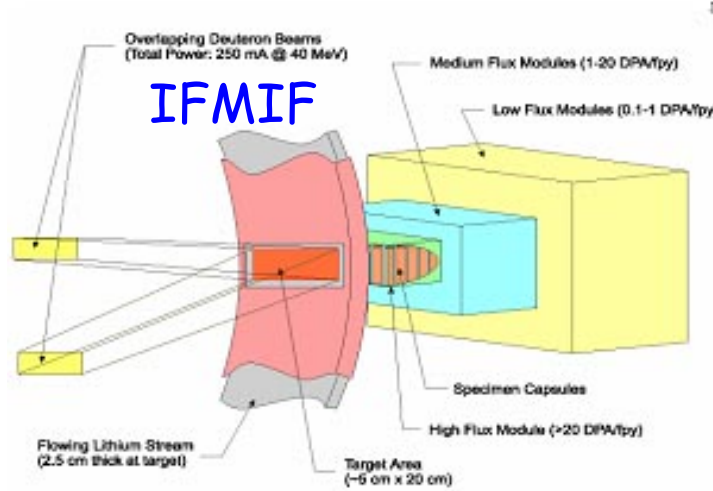

IFMIF

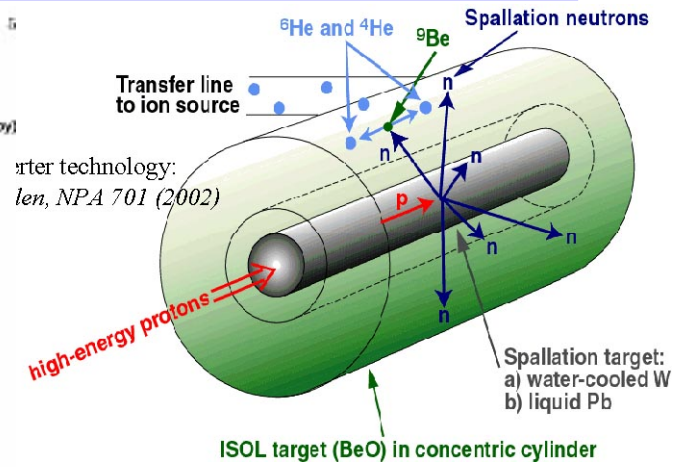

arter technology:
len, NPA 701 (2002)

ISOL/ β Beams

PSI

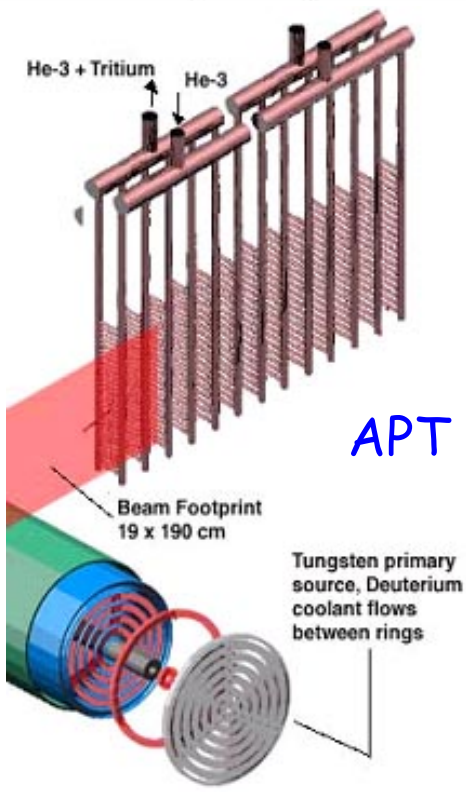
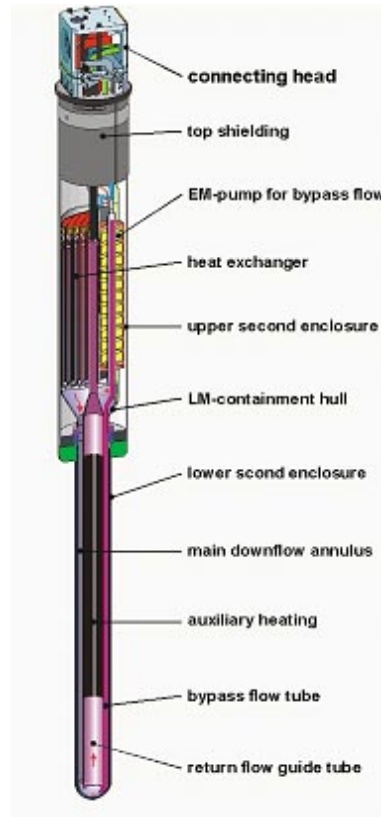

APT

ATW

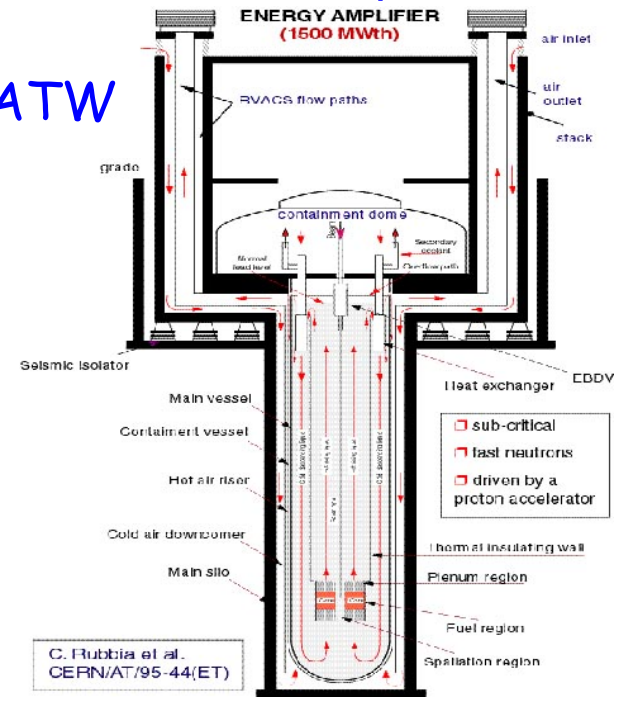

2-4 MW Proton Beams

- 10-50 GeV beam energy appropriate for Superbeams, Neutrino Factories and Muon Colliders.
 - $0.8-2.5 \times 10^{15}$ pps; $0.8-2.5 \times 10^{22}$ protons per year of 10^7 s.
 - Rep rate 15-50 Hz at Neutrino Factory/Muon Collider, as low as ≈ 2 Hz for Superbeam.
 - ⇒ Protons per pulse from 1.6×10^{13} to 1.25×10^{15} .
 - ⇒ Energy per pulse from 80 kJ to 2 MJ.
 - Small beam size preferred:
 - $\approx 0.1 \text{ cm}^2$ for Neutrino Factory/Muon Collider, $\approx 0.2 \text{ cm}^2$ for Superbeam.
 - Pulse width $\approx 1 \mu\text{s}$ OK for Superbeam, but $\approx 1 \text{ ns}$ desired for Neutrino Factory/Muon Collider.
- ⇒ Severe materials issues for target AND beam dump.
- Radiation Damage.
 - Melting.
 - Cracking (due to single-pulse "thermal shock").
- MW energy dissipation requires liquid coolant somewhere in system!
 - ⇒ No such thing as "solid target only option" at this power level.
-

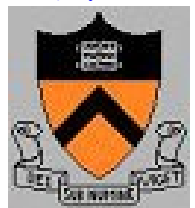

Radiation Damage

The lifetime dose against radiation damage (embrittlement, cracking,) by protons for most solids is about $10^{22}/\text{cm}^2$.

- ⇒ Target lifetime of about 5-14 days at a 4-MW Neutrino Factory (and 9-28 days at a 2-MW Superbeam).
- ⇒ Mitigate by frequent target changes, moving target, liquid target, ... [Mitigated in some materials by annealing/operation at elevated temperature.]



Remember the Beam Dump

Target of 2 interaction lengths \Rightarrow 1/7 of beam is passed on to the beam dump.
 \Rightarrow Energy deposited in dump by primary protons is same as in target.

Long distance from target to dump at a Superbeam,
 \Rightarrow Beam is much less focused at the dump than at the target,
 \Rightarrow Radiation damage to the dump not a critical issue (Superbeam).

Short distance from target to dump at a Neutrino Factory/Muon Collider,
 \Rightarrow Beam still tightly focused at the dump,
 \Rightarrow Frequent changes of the beam dump, or a moving dump, or a liquid dump.

A liquid beam dump is the most plausible option for a Neutrino Factory, independent of the choice of target. (This is so even for a 1-MW Neutrino Factory.)

The proton beam should be tilted with respect to the axis of the capture system at a Neutrino Factory, so that the beam dump does not absorb the captured π 's and μ 's.

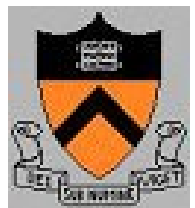

Target and Capture Topologies: Toroidal Horn

The traditional topology for efficient capture of secondary pions is a toroidal "horn" (Van der Meer, 1961).

- Collects only one sign, \Rightarrow Longer data runs, but nonmagnetic detector (Superbeam).
- Inner conductor of toroid very close to proton beam.
 - \Rightarrow Limited life due to radiation damage at 4 MW.
 - \Rightarrow Beam, and beam dump, along magnetic axis.
 - \Rightarrow More compatible with Superbeam than with Neutrino Factory/Muon Collider.

0.75-MW Graphite target with He gas cooling (T2K):

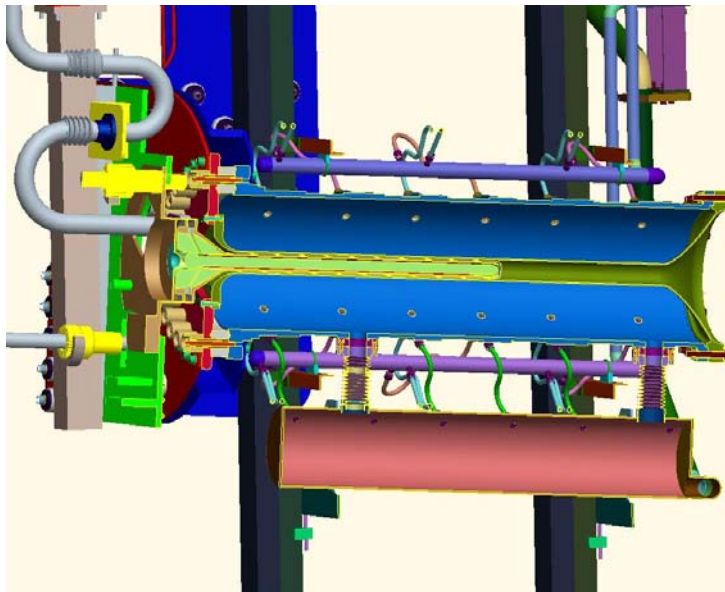

Mercury jet target (CERN SPL study):

2.2 GeV
at 4MW
50 Hz
operation
Protons \rightarrow

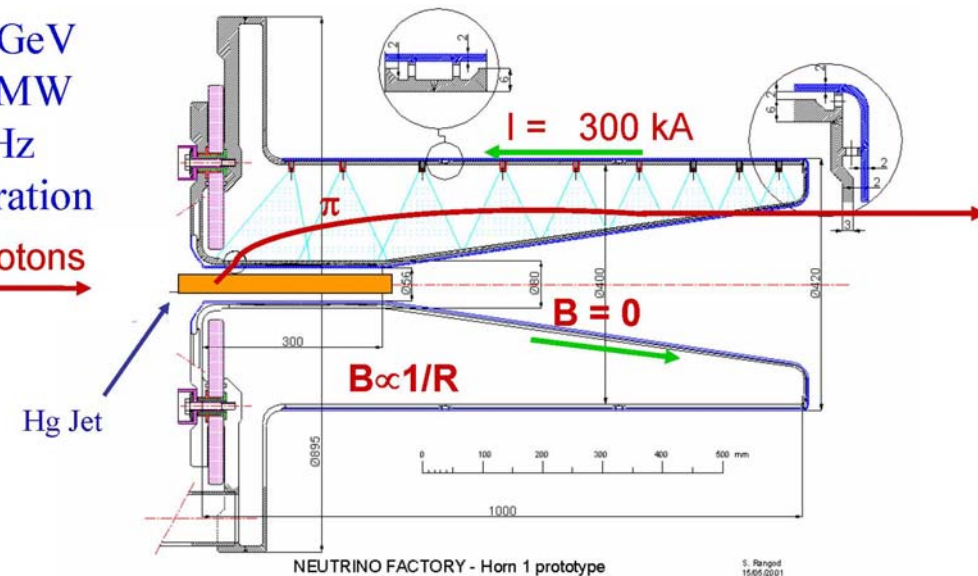

If desire secondary pions with $E_{\pi} \leq 5$ GeV (Neutrino Factory), a high- Z target is favored, but for $E_{\pi} \geq 10$ GeV (some Superbeams), low Z is preferred.

Target and Capture Topologies: Solenoid

Desire $\approx 10^{14}$ μ /s from $\approx 10^{15}$ p/s (≈ 4 MW proton beam).

Highest rate μ^+ beam to date: PSI μ E4 with $\approx 10^9$ μ /s from $\approx 10^{16}$ p/s at 600 MeV.

\Rightarrow Some R&D needed!

Palmer (1994) proposed a solenoidal capture system.

Low-energy π 's collected from side of long, thin cylindrical target.

Collects both signs of π 's and μ 's,

\Rightarrow Shorter data runs (with magnetic detector).

Solenoid coils can be some distance from proton beam.

\Rightarrow ≥ 4 -year life against radiation damage at 4 MW.

Liquid mercury jet target replaced every pulse.

Proton beam readily tilted with respect to magnetic axis.

\Rightarrow Beam dump (mercury pool) out of the way of secondary π 's and μ 's.

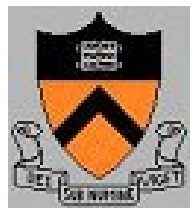
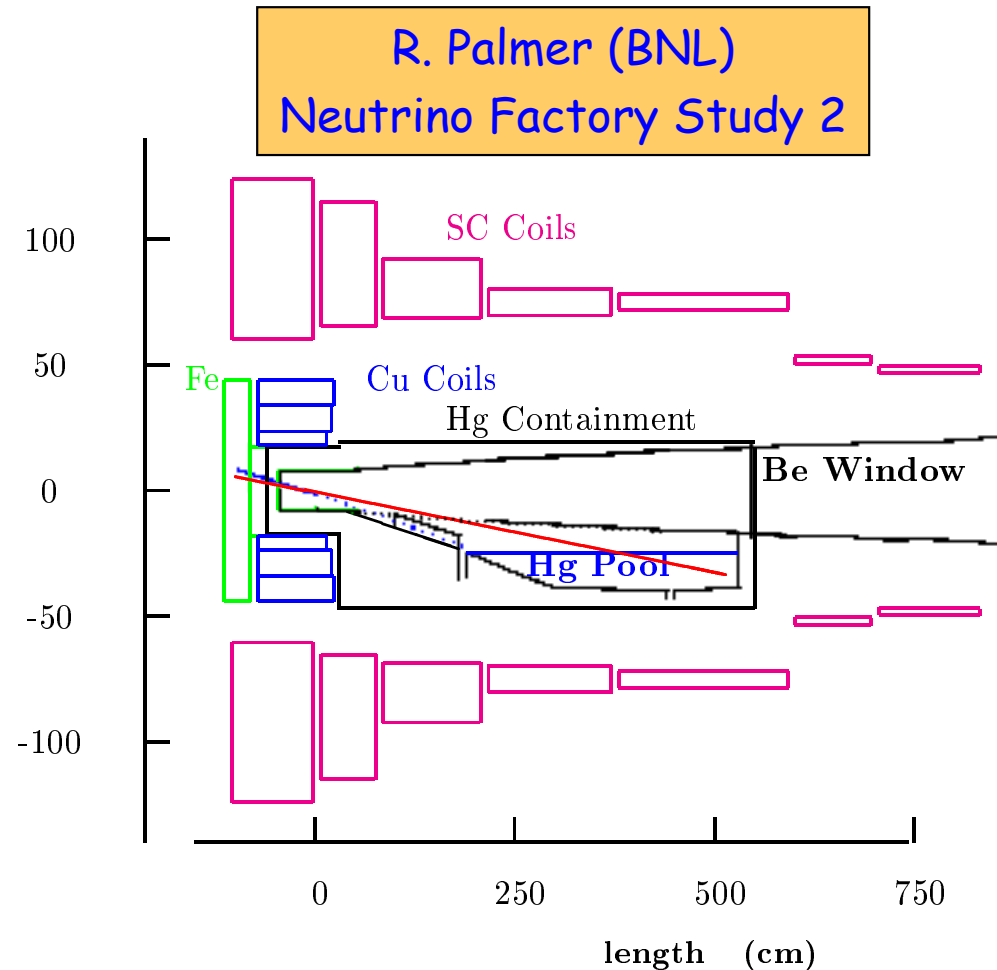

Solenoid Capture System for a Superbeam

- Pions produced on axis inside the (uniform) solenoid have zero canonical angular momentum $L_z = r(P_\phi + eA_\phi / c) = 0, \Rightarrow P_\phi = 0$ on exiting the solenoid.
- If the pion has made exactly 1/2 turn on its helix when it reaches the end of the solenoid, then its initial P_r has been rotated into a pure $P_\phi, \Rightarrow P_r = 0$ on exiting the solenoid.

\Rightarrow Point-to-parallel focusing for

$$P_\pi = eBd / (2n + 1) \pi c.$$

\Rightarrow Narrowband (less background) neutrino beams of energies

$$E_\nu \approx \frac{P_\pi}{2} = \frac{eBd}{(2n + 1)2\pi c}.$$

\Rightarrow Can study several neutrino oscillation peaks at once,

$$\frac{1.27 M_{23}^2 [\text{eV}^2] L [\text{km}]}{E_\nu [\text{GeV}]} = \frac{(2n + 1)\pi}{2}.$$

(Marciano, hep-ph/0108181)

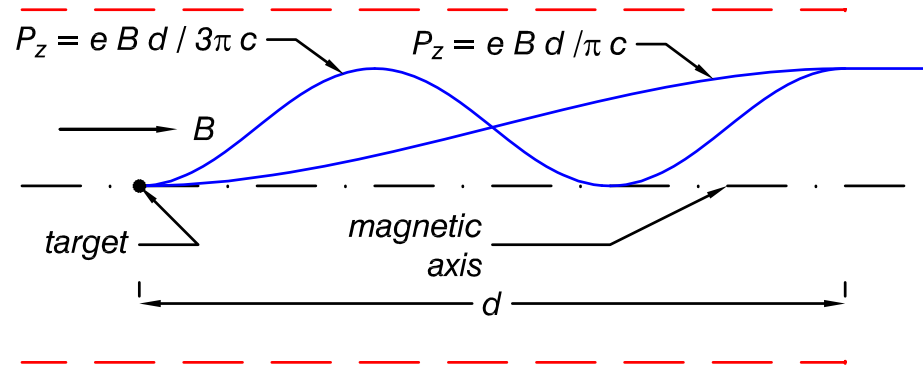
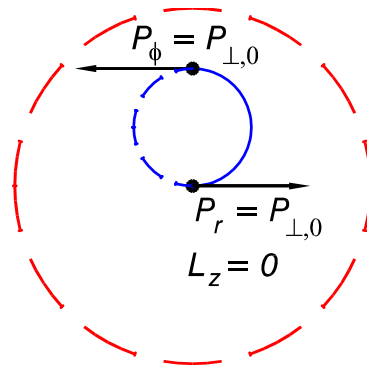

(KTM, physics/0312022)

Study both ν and $\bar{\nu}$ at the same time.

\Rightarrow Detector must identify sign of μ and e .

\Rightarrow Magnetized liquid argon TPC [TASD?].

(astro-ph/0105442).

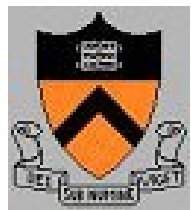

Simulation of Solenoid Horn

(H. Kirk and R. Palmer, NuFACT06)

B vs. z for 3 + 30 m solenoid:

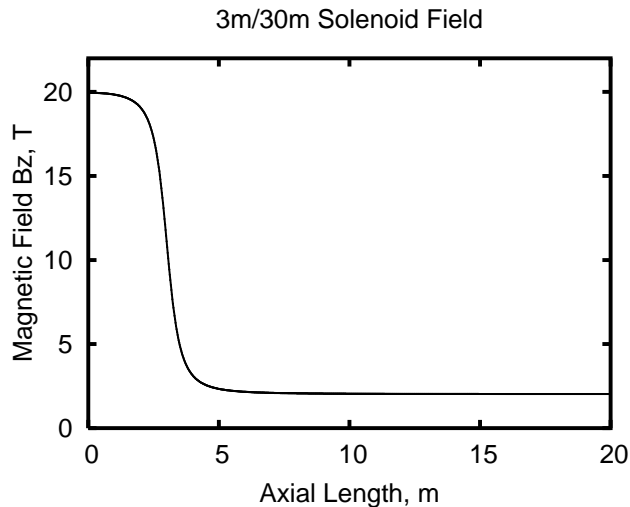

3-m solenoid gives
2 narrow peaks
in ν spectrum:

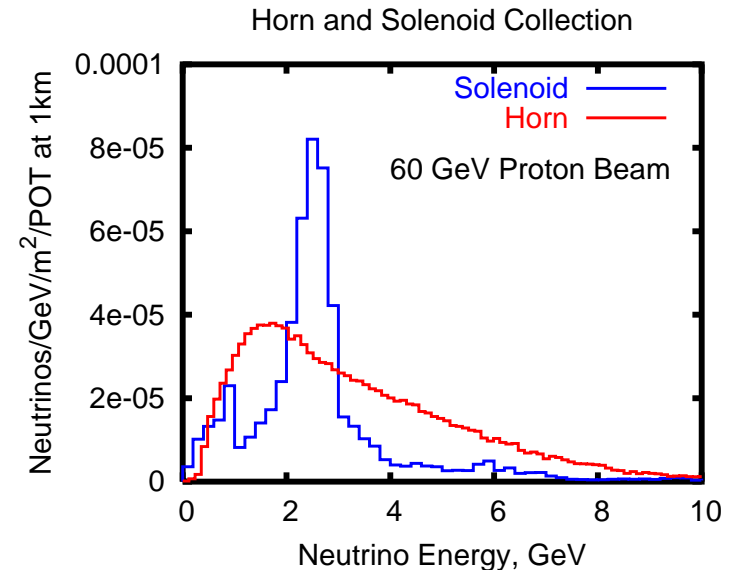

P_{\perp} minimized at selected P_{tot} :
Stepped Taper

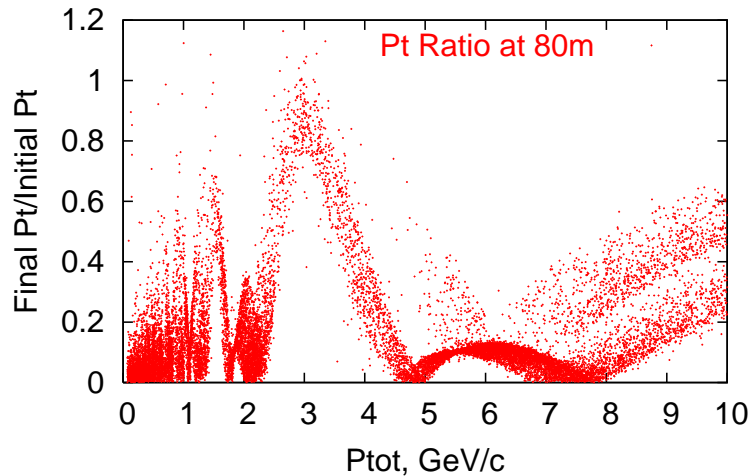

3+30-m solenoid
broadens the
higher energy
peak:

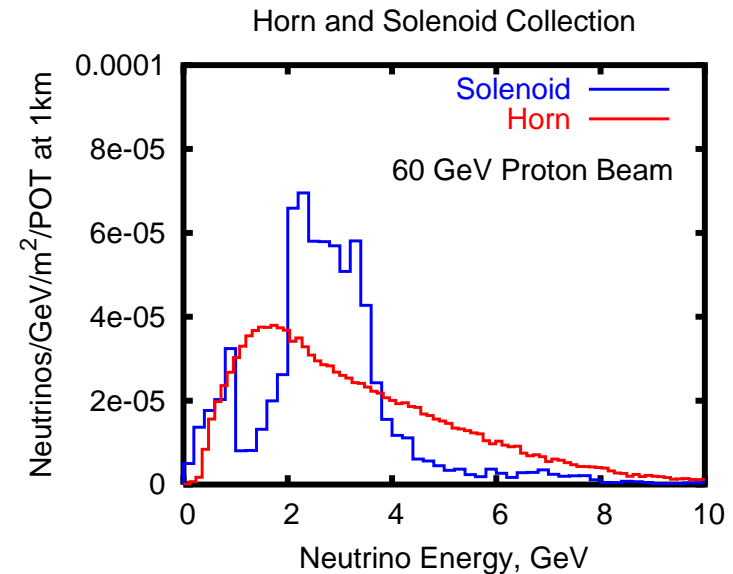

Results very encouraging, but comparison with toroid horn needs confirmation.

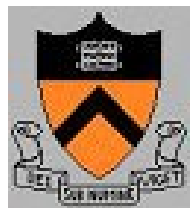

Target Options

- Static Solid Targets

- Graphite (or carbon composite) cooled by water/gas/radiation [CNGS, NuMI, T2K]
- Tungsten or Tantalum (discs/rods/beads) cooled by water/gas [PSI, LANL]

- Moving Solid Targets

- Rotating wheels/cylinders cooled (or heated!) off to side [SLD, FNAL \bar{p} , Bennett]
- Continuous or discrete belts/chains [King]
- Flowing powder [Densham]

- Flowing liquid in a vessel with beam windows [SNS, ESS]

- Free liquid jet [Neutrino Factory Study 2]

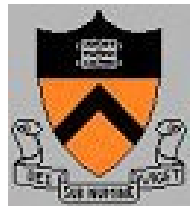

Static Solid Targets

Pros:

- Tried and true - for low power beams.
- Will likely survive "thermal shock" of long beam pulses at 2 MW (Superbeam).

Cons:

- Radiation damage will lead to reduced particle production/mechanical failure on the scale of a few weeks at 2 MW.
- If liquid cooled, leakage of radioactive coolant anywhere in the system is potentially more troublesome than breakup of a radioactive solid.

⇒ Must consider a "moving target" later if not sooner.

R&D: Test targets to failure in high-power beams to determine actual operational limits.

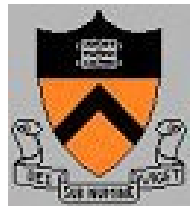

Moving Solid Targets

Pros:

- Can avoid radiation damage limit of static solid targets.
- Will likely survive "thermal shock" of long beam pulses at 2 MW (Superbeam).

Cons:

- Target geometry not very compatible with neutrino "horns" except when target is upstream of horn (high energy ν 's: CNGS, NuMI).
- If liquid cooled, leakage of radioactive coolant anywhere in the system is potentially more troublesome than breakup of a radioactive solid.

R&D:

- Engineering to clarify compatibility with a target station for Superbeams.
- Lab studies of erosion of nozzle by powders.

Personal view: this option is incompatible with Neutrino Factories.



Flowing Liquids in Vessels

Pros:

- The liquid flows through well-defined pipes.
- Radiation damage to the liquid is not an issue.

Cons:

- The vessel must include static solid beam windows, whose lifetime will be very short in the small proton spot sizes needed at Superbeams and Neutrino Factories.
- Cavitation in the liquid next to the beam windows is extremely destructive.
- Leakage of radioactive liquid anywhere in the system is potentially more troublesome than breakup of a radioactive solid.

R&D: This option is not very plausible for Superbeams and Neutrino Factories, and no R&D is advocated.



Free Liquid Jet Targets

Pros:

- No static solid window in the intense proton beam.
- Radiation damage to the liquid is not an issue.

Cons:

- Never used before as a production target.
- Leakage of radioactive liquid anywhere in the system is potentially more troublesome than breakup of a radioactive solid.

R&D: Proof of principle of a free liquid jet target has been established by the CERN MERIT Experiment. R&D would be useful to improve the jet quality, and to advance our understanding of systems design issues.

Personal view: This option deserves its status as the baseline for Neutrino Factories and Muon Colliders. For Superbeams that will be limited to less than 2 MW, static solid targets continue to be appealing.

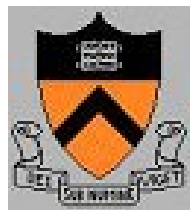

Thermal Issues for Solid Targets, I

The quest for efficient capture of secondary pions precludes traditional schemes to cool a solid target by a liquid. (Absorption by plumbing; cavitation of liquid.)

A solid, radiation-cooled stationary target in a 4-MW beam will equilibrate at about 2500 C.
⇒ Carbon is only candidate for this type of target.

Carbon target must be in He atmosphere to suppress sublimation.

(Neutrino Factory Study 1)

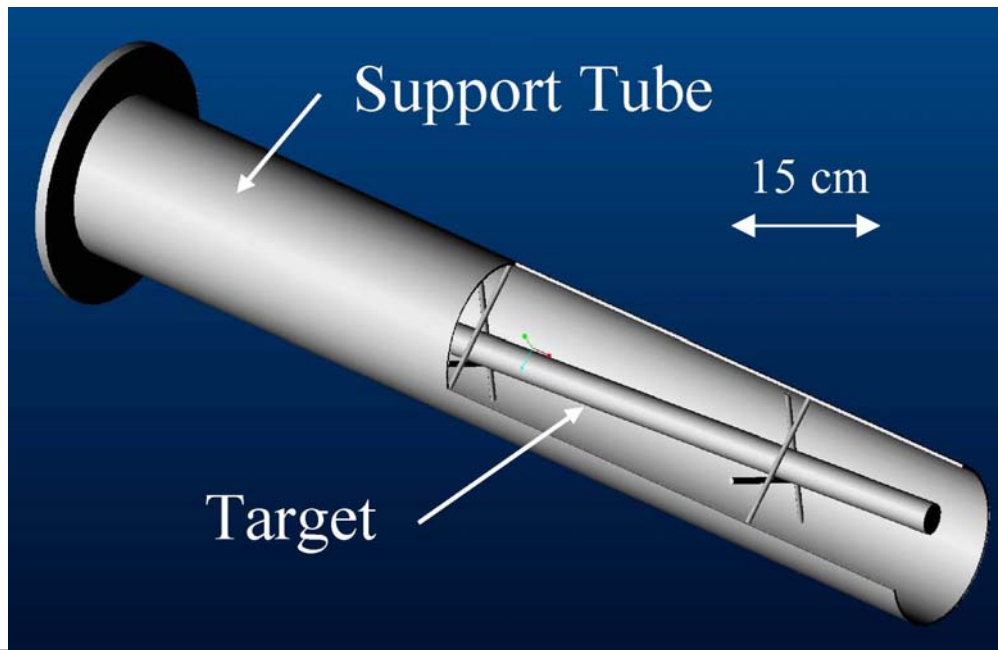

A moving band target (Ta, W, ...) could be considered (if capture system is toroidal).

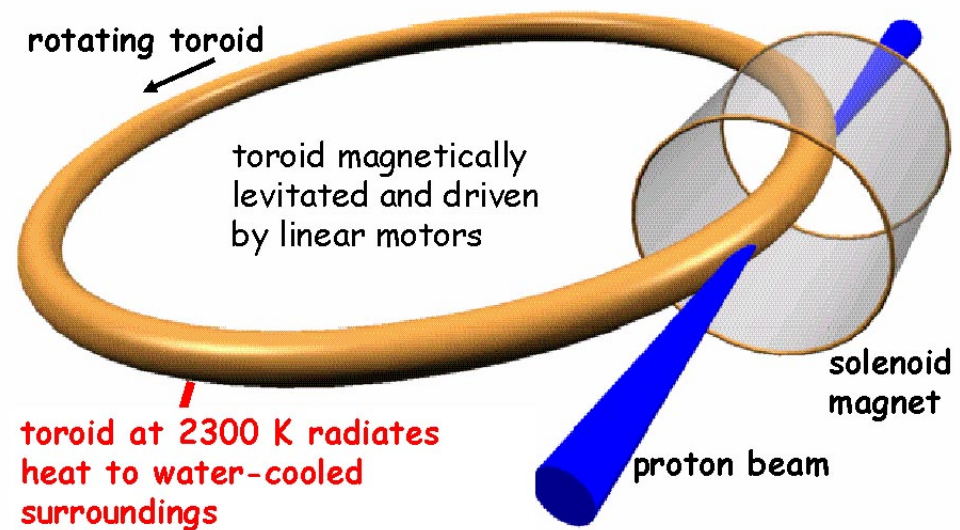

B. King (BNL), R. Bennett (RAL)



Thermal Issues for Solid Targets, II

When beam pulse length t is less than target radius r divided by speed of sound v_{sound} , beam-induced pressure waves (thermal shock) are a major issue.

Simple model: if U = beam energy deposition in, say, Joules/g, then the instantaneous temperature rise ΔT is given by

$$\Delta T = \frac{U}{C}, \quad \text{where } C = \text{heat capacity in Joules/g/K.}$$

The temperature rise leads to a strain $\Delta r / r$ given by

$$\frac{\Delta r}{r} = \alpha \Delta T = \frac{\alpha U}{C}, \quad \text{where } \alpha = \text{thermal expansion coefficient.}$$

The strain leads to a stress P (= force/area) given by

$$P = E \frac{\Delta r}{r} = \frac{E \alpha U}{C}, \quad \text{where } E = \text{modulus of elasticity.}$$

In many metals, the tensile strength obeys $P \approx 0.002 E$, $\alpha \approx 10^{-5}$, and $C \approx 0.3 \text{ J/g/K}$, in which case

$$U_{\text{max}} \approx \frac{PC}{E\alpha} \approx \frac{0.002 \cdot 0.3}{10^{-5}} \approx 60 \text{ J/g.}$$

⇒ Best candidates for solid targets have high strength (Vascomax, Inconel, TiAl6V4) and/or low thermal expansion (Superinvar, Toyota "gum metal", carbon-carbon composite).

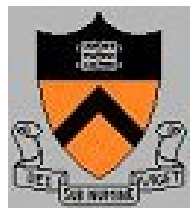

How Much Beam Power Can a Solid Target Stand?

How many protons are required to deposit 60 J/g in a material?

What is the maximum beam power P this material can withstand without cracking, for a 10-GeV beam at 10 Hz with area 0.1 cm².

Ans: If we ignore "showers" in the material, we still have dE/dx ionization loss, of about 1.5 MeV/g/cm².

Now, 1.5 MeV = 2.46×10^{-13} J, so 60 J/g requires a proton beam intensity of $60 / (2.4 \times 10^{-13}) = 2.4 \times 10^{14}$ /cm².

So, $P_{\max} \approx 10 \text{ Hz} \cdot 10^{10} \text{ eV} \cdot 1.6 \times 10^{-19} \text{ J/eV} \cdot 2.4 \times 10^{14} / \text{cm}^2 \cdot 0.1 \text{ cm}^2 \approx 4 \times 10^5 \text{ J/s} = 0.4 \text{ MW}$.

If solid targets crack under singles pulses of 60 J/g, then safe up to only 0.4 MW beam power!

Empirical evidence is that some materials survive 500-1000 J/g
 \Rightarrow May survive 4 MW if rep rate ≥ 10 Hz.

Ni target in FNAL \bar{p} source: "damaged but not failed"
peak energy deposition of 1500 J/g.

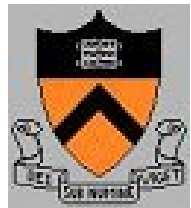

A Carbon Target is Feasible at 1-2 MW Beam Power

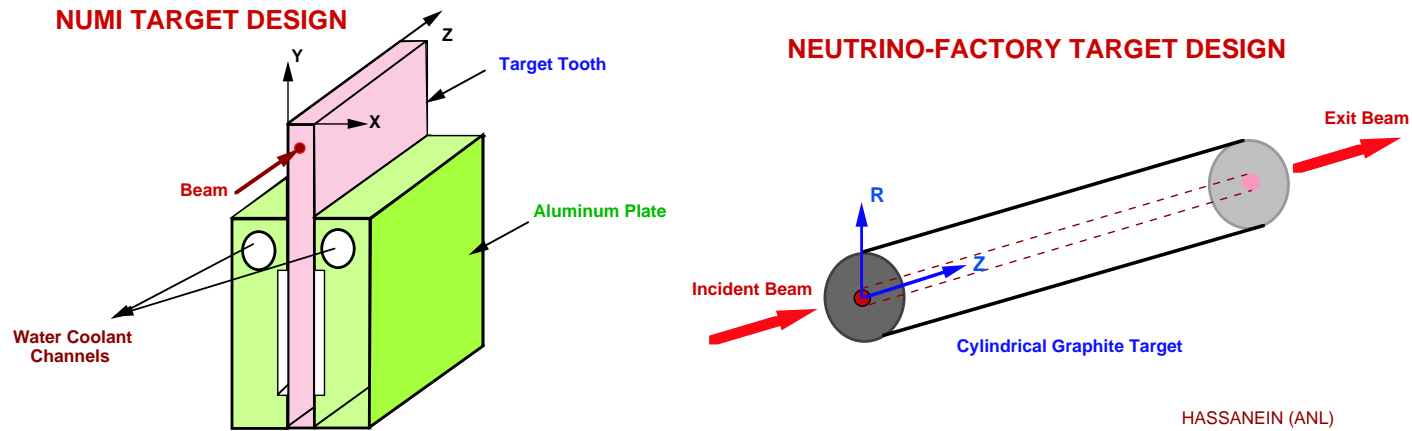

Low energy deposition per gram and low thermal-expansion coefficient reduce thermal "shock" in carbon.

Operating temperature $> 2000\text{ C}$ if use only radiation cooling.

A carbon target in vacuum would sublime away in 1 day at 4 MW, but sublimation of carbon is negligible in a helium atmosphere.

Radiation damage is limiting factor: ≈ 12 weeks (?) at 1 MW.

\Rightarrow Carbon target is baseline design for most neutrino superbeams.}

Useful pion capture increased by compact, high-Z target, \Rightarrow Continued R&D on solid targets.

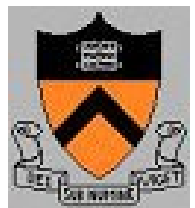

The samples were placed individually into an ATOM-LAB 100 dose calibrator in order to measure the integrated activation levels. The first (entrance) plane (Fig. 1) consisted of unnecked-down rods and wire positioned in a horizontal orientation, while the fourth (exit) plane had a similar arrangement but with a vertical orientation. The activation levels of the front plane could then be used to extract information as to the vertical profile of the incident proton beam, while the exit plane could be used for obtaining the horizontal profile of the proton beam (Fig. 2). The nickel wire and Invar rods have different volumes as well as composition, hence overall normalization for each data set differ. However, the beam rms widths extracted from each set of material agree well.

Material Irradiation Studies

ATJ graphite and a 3-D weave of carbon carbon fibers instrumented with fiberoptic strain sensors, and exposed to pulses of 4×10^{12} protons @ 24 GeV.

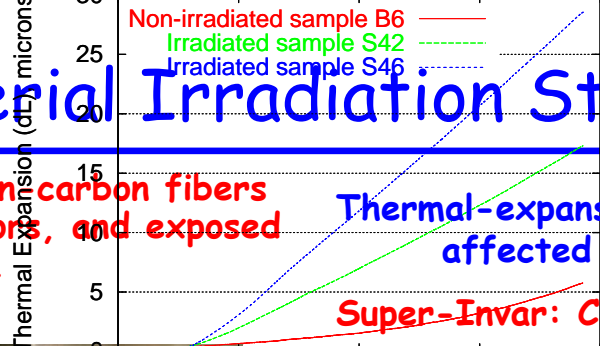

Thermal-expansion coefficient of engineered materials is affected by radiation.

Super-Invar: CTE \ vs\ dose:



Figure 3: Measured thermal expansions

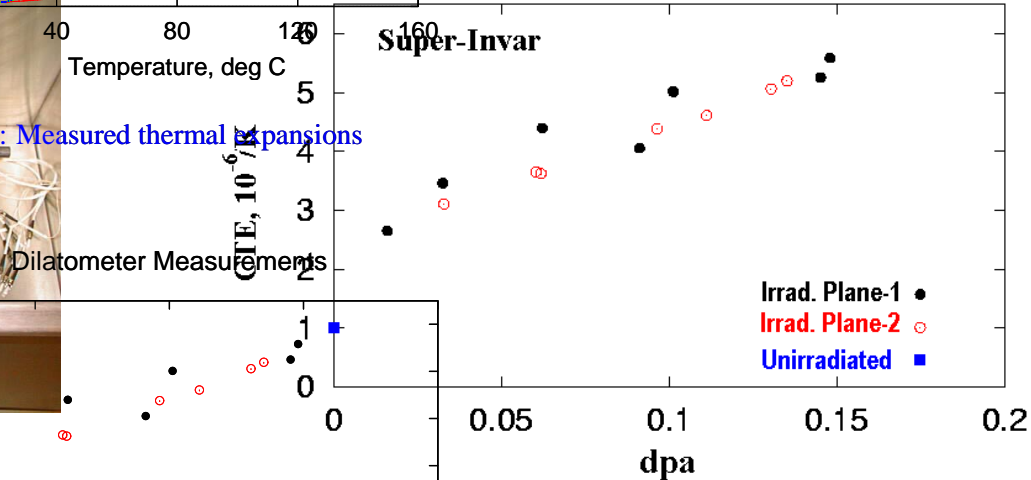

Super Invar: recovery of the CTE by thermal annealing:

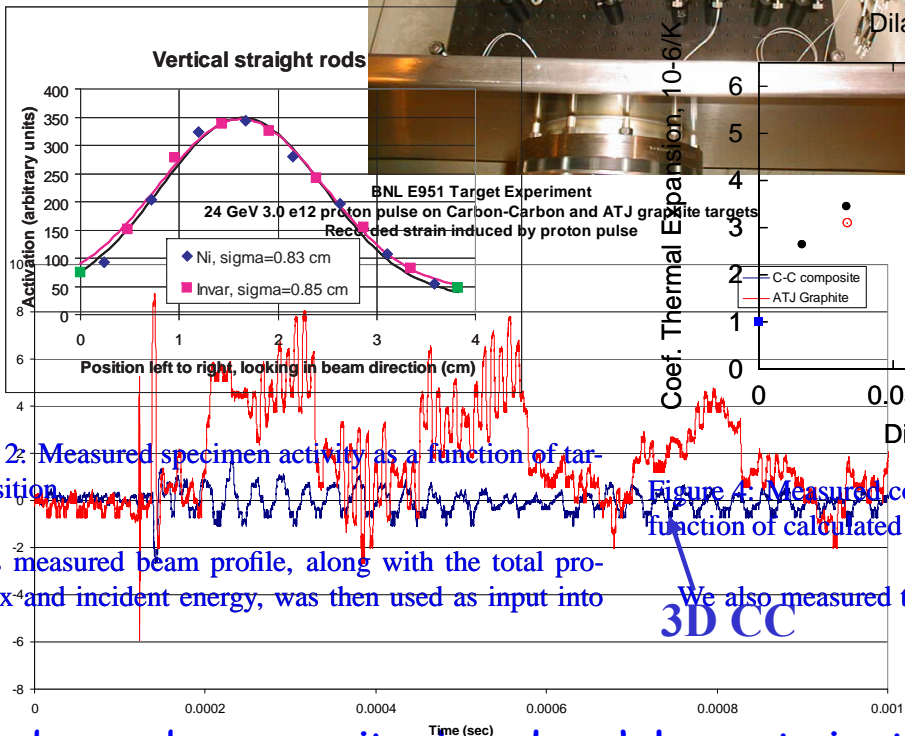
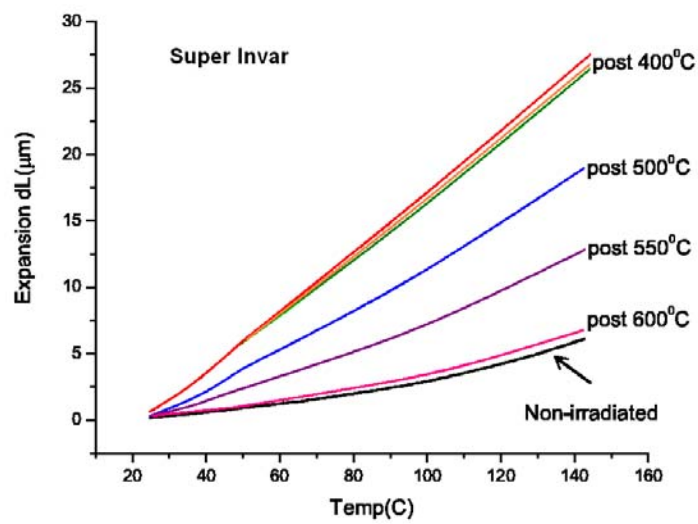

Figure 2: Measured specimen activity as a function of target position.

Figure 4: Measured coefficients of thermal expansion as a function of calculated atomic displacement.

This measured beam profile, along with the total proton flux and incident energy, was then used as input into

We also measured the CTE of the 3D CC



Carbon-carbon composite showed much lower strains than in the ordinary graphite -- but readily damaged by radiation!



Radiation Damage Studies at BNL (Simos)

Irradiation takes place at BLIP using 200 MeV or 117 MeV protons at the end of Linac

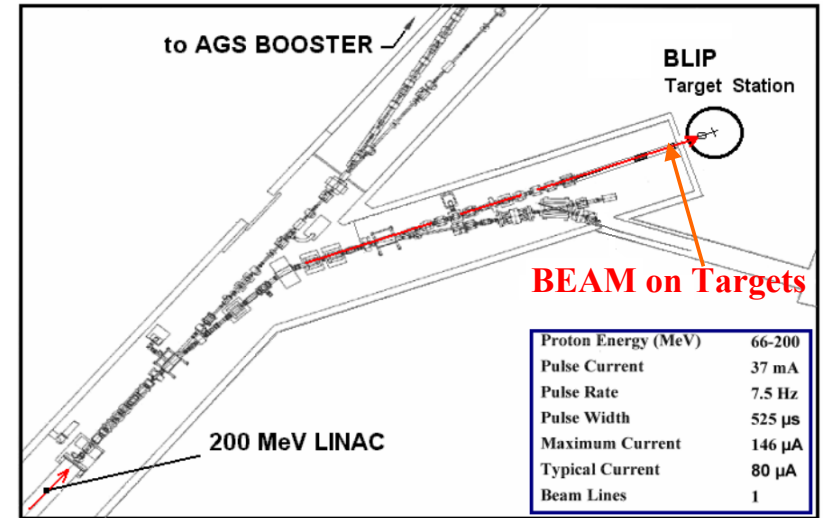
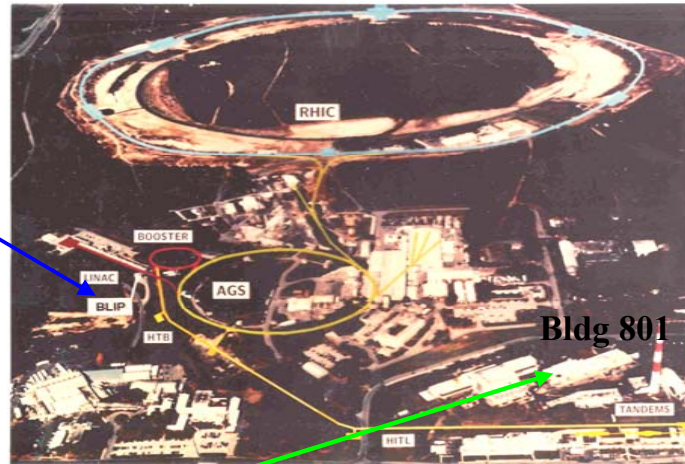

Post-irradiation analysis at BNL Hot Labs



Remotely operated mechanical testing system

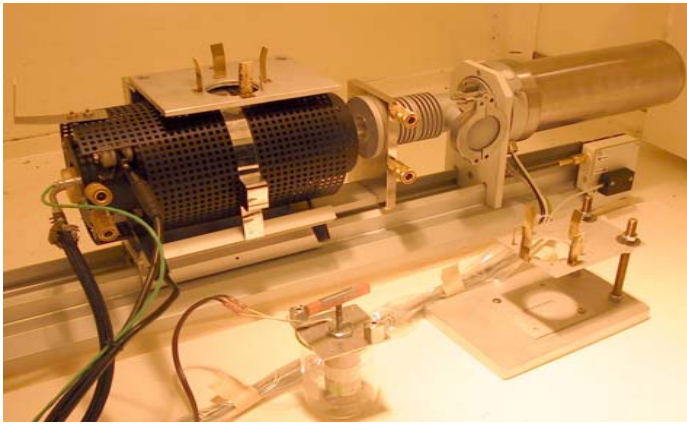

Thermal Expansion/Heat Capacity Measuring System



Recent/Ongoing Solid Target Projects

MiniBooNE Horn Target

Up to 5×10^{12} 8-GeV protons.

Survived 10^8 pulses.

Gas-cooled Be target.

30 kW beam power.

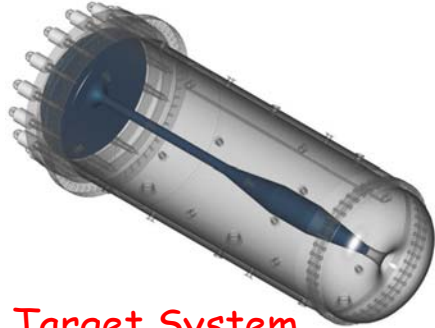

NUMI Target Upgrade

Up to 1.5×10^{14} 120-GeV protons every 1.4 s.

Beam $\sigma = 1.5$ mm.

Designed for 1-2 MW.

Graphite + water cooling.

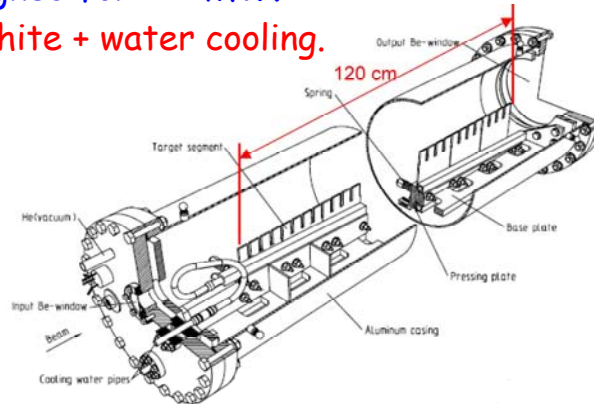

Pulsed-Current Studies of Ta & W Wires at RAL (R.Bennett et al.)

Photograph of the tantalum wire showing characteristic wiggles before failure.

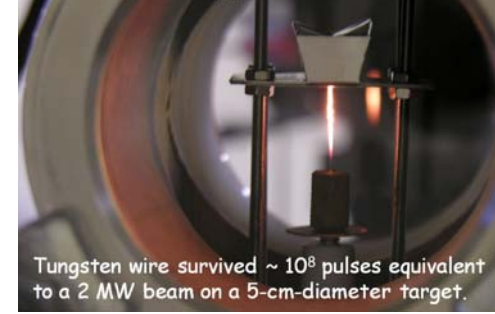

solenoids

Target Bars

The target bars are connected by links - like a bicycle chain.

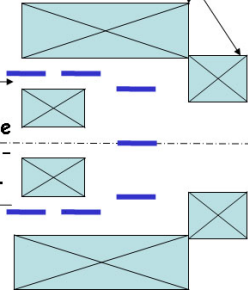

Flowing Tungsten Powder Targets (C.Densham et al., RAL)

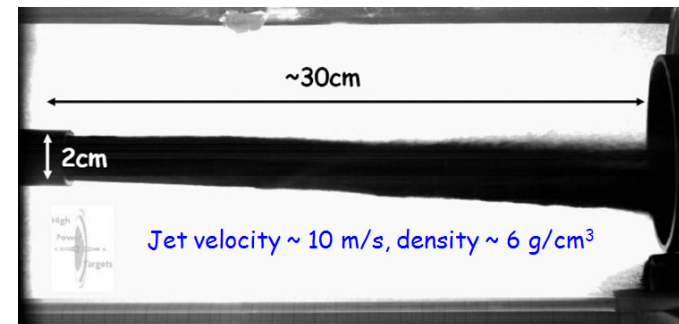

CNGS Target System

Up to 7×10^{13} 400-GeV protons every 6 s.

Beam $\sigma = 0.5$ mm.

5 interchangeable graphite targets.

Designed for 0.75 MW.



JPARC v Horn Target

Up to 4×10^{14} 50-GeV protons every 4 s.

Beam $\sigma = 4$ mm.

Designed for 0.75 MW.

Graphite + He gas cooling.

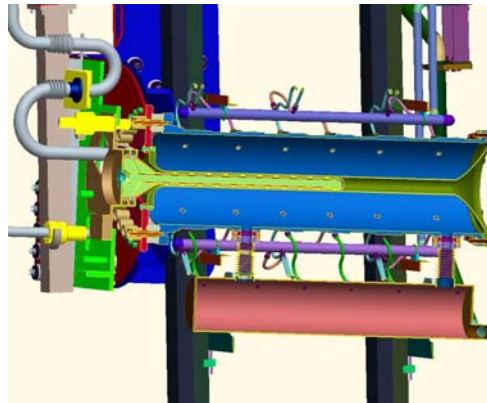

Beam-Induced Cavitation in Liquids Can Break Pipes

ISOLDE:



Hg in a pipe (BINP):

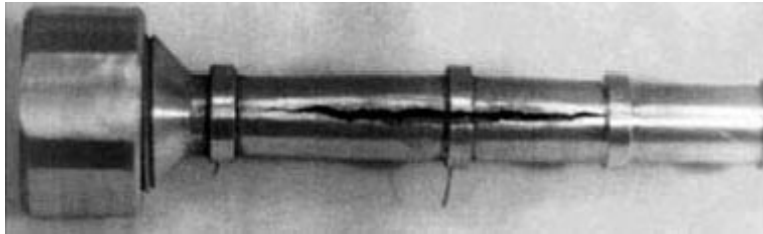

Cavitation pitting of SS wall surrounding Hg target after 100 pulses (SNS):

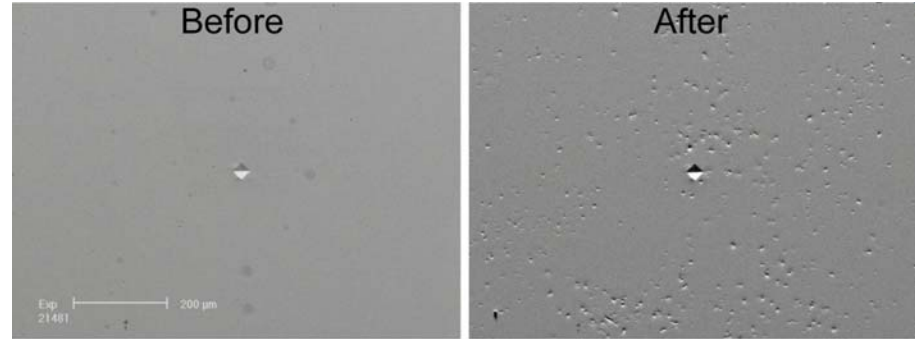

TL - High Power Target
Specimen # 29754
Equivalent SNS Power Level = 2.5

Mitigate(?) by gas buffer \Rightarrow free Hg surface:

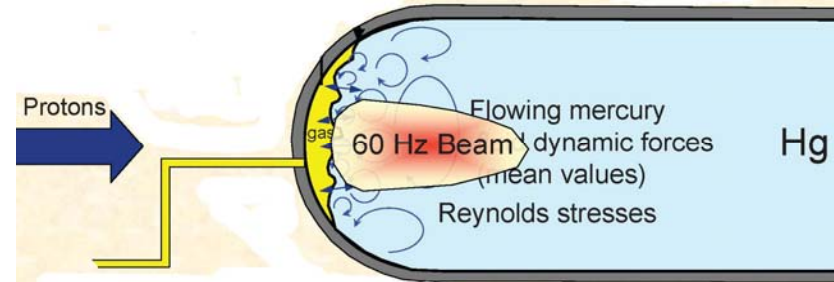

Water jacket of NuMI target developed a leak after \approx 1 month.

Perhaps due to beam-induced cavitation.

Ceramic drainpipe/voltage standoff of water cooling system of CNGS horn failed after 2 days operation at high beam power. (Not directly a beam-induced failure.)

\Rightarrow Use free liquid jet if possible.

Neutrino Factory Feasibility Study 2

Infrastructure studies based on SNS mercury target experience.

ORNL/TM-2001/124, P. Spampinato et al.

<http://www.hep.princeton.edu/~mcdonald/mumu/target/tm-2001-124.pdf>

Should be extended during the Muon Collider Feasibility Study.

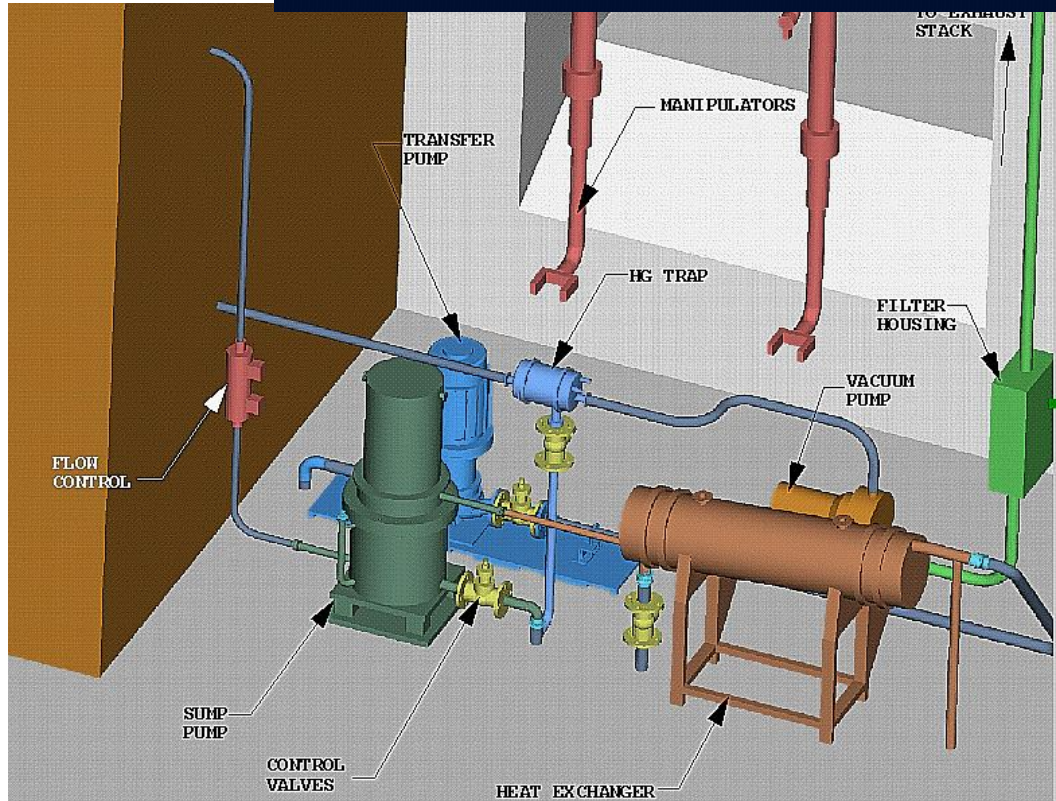
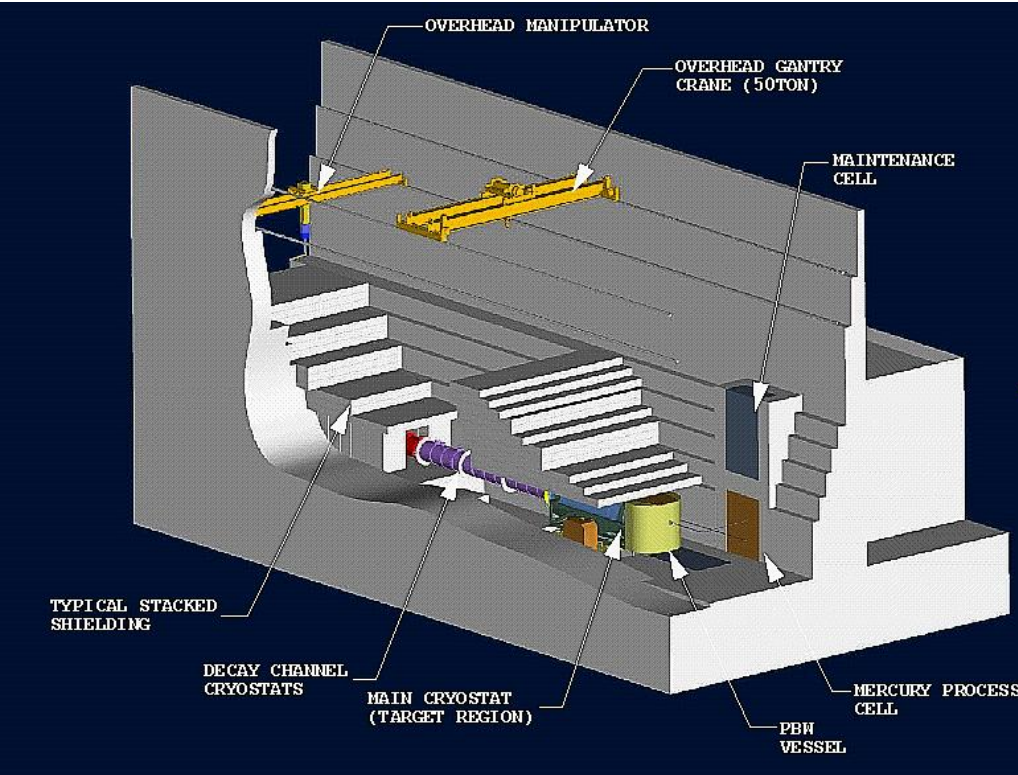
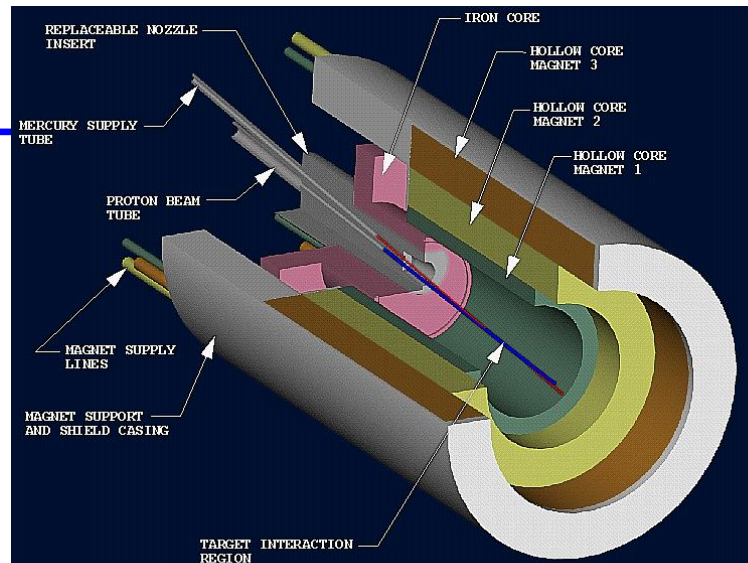

Features of the Study 2 Target Design

Mercury jet with 1-cm diameter, 20 m/s velocity, at 100 mrad to magnetic axis.

4-MW, 24-GeV, 50-Hz proton beam (2×10^{13} p/pulse) at 67 mrad to magnetic axis.

Iron plug at upstream end of capture solenoid to reduce fringe-field effect on shape of free jet.

Mercury collected in a pool in ~ 4 T magnetic field.

Issues: Distortion of jet by magnetic field.

Disruption of jet by proton beam.

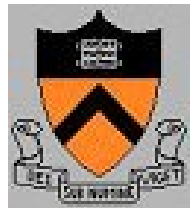
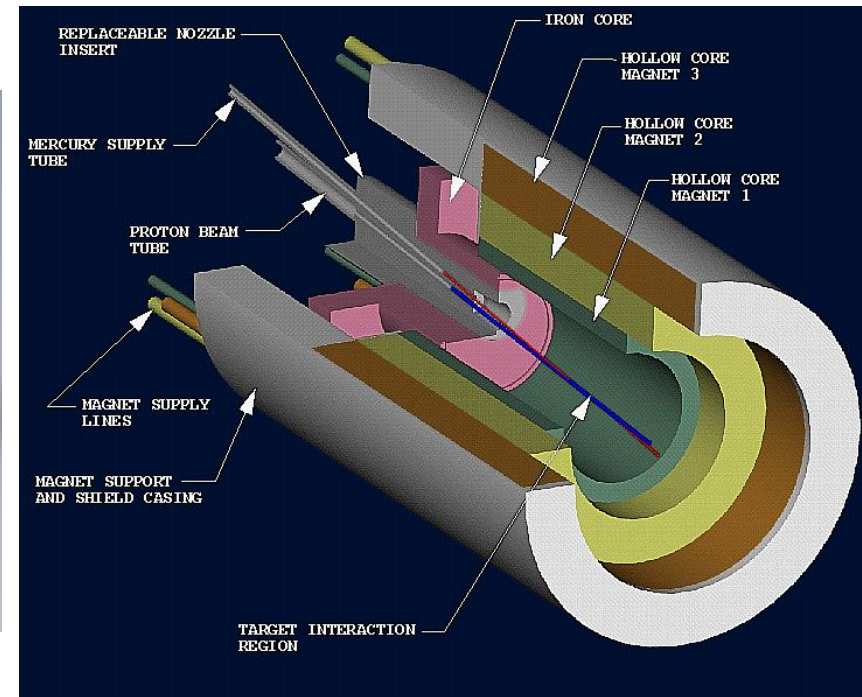
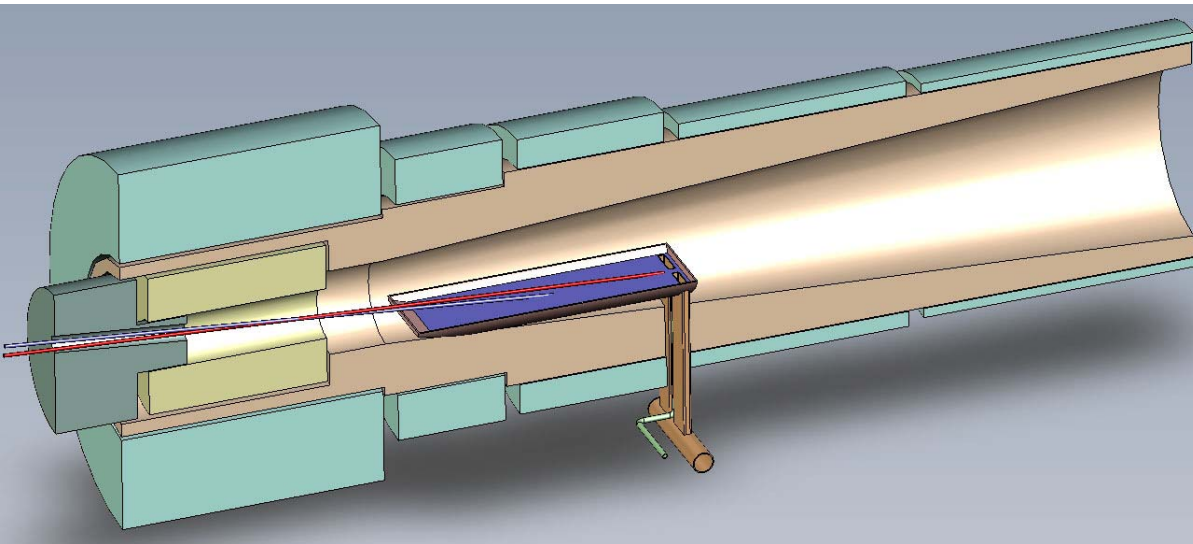

Beam-Induced Effects on a Free Liquid Jet

Beam energy deposition may disperse the jet.

FRONTIER simulation predicts breakup via filamentation on mm scale:

R. Samulyak (BNL)

Mercury target: evolution after the first proton pulse
(0 - 10 microseconds)

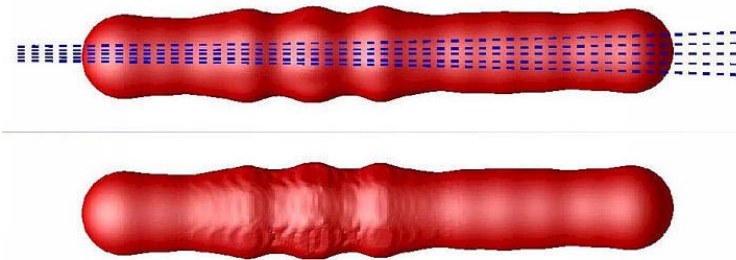

Brookhaven Science Associates
U.S. Department of Energy

BROOKHAVEN
NATIONAL LABORATORY

Mercury target: evolution after the third proton pulse
(20 - 35 microseconds)

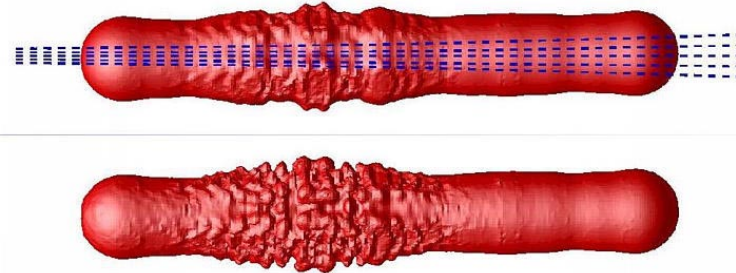

Brookhaven Science Associates
U.S. Department of Energy

BROOKHAVEN
NATIONAL LABORATORY

Laser-induced breakup
of a water jet:

J. Lettry (CERN)

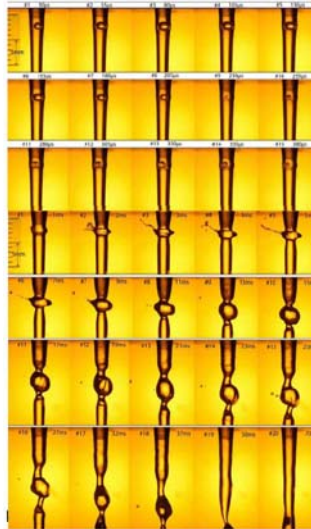

Water jet ripples generated by a
8 mJ Laser cavitation bubble

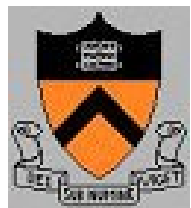

Mercury Target Tests (BNL-CERN, 2001-2002)

Mercury thimble:

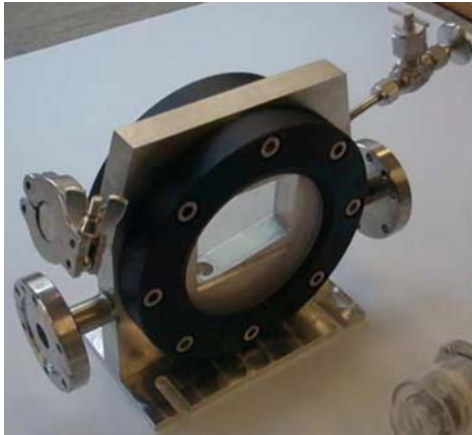

2-m.s free mercury jet:

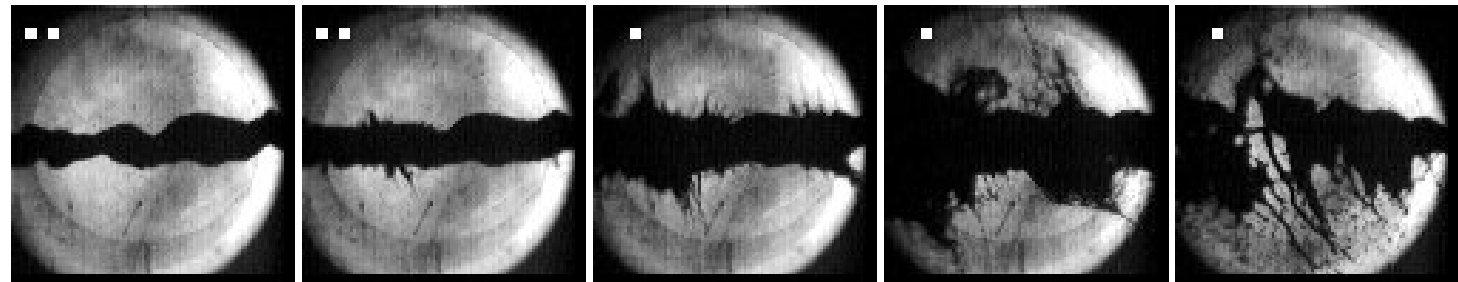
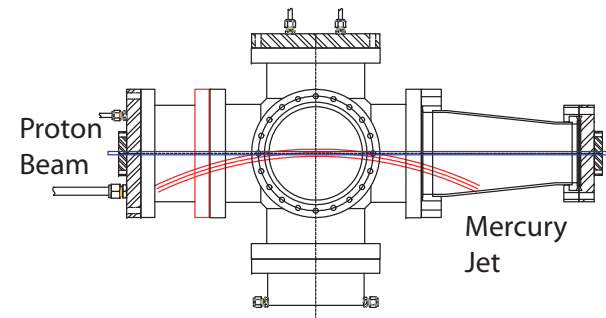

Data: $v_{\text{dispersal}} \approx 10 \text{ m/s}$ for $U \approx 25 \text{ J/g}$.

$v_{\text{dispersal}}$ appears to scale with proton intensity.

The dispersal is not destructive.

Filaments appear only $\approx 40 \mu\text{s}$ after beam,

\Rightarrow After several bounces of waves, OR v_{sound} very low.

Model:

$$v_{\text{dispersal}} = \frac{\Delta r}{\Delta t} = \frac{r\alpha\Delta T}{r/v_{\text{sound}}} = \frac{\alpha U}{C} v_{\text{sound}} \approx 50 \text{ m/s}$$

for $U = 25 \text{ J/g}$.

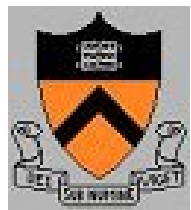

Mercury Jet Studies at Grenoble High Field Magnet Lab (2002)

Rayleigh surface instability damped by high magnetic field.

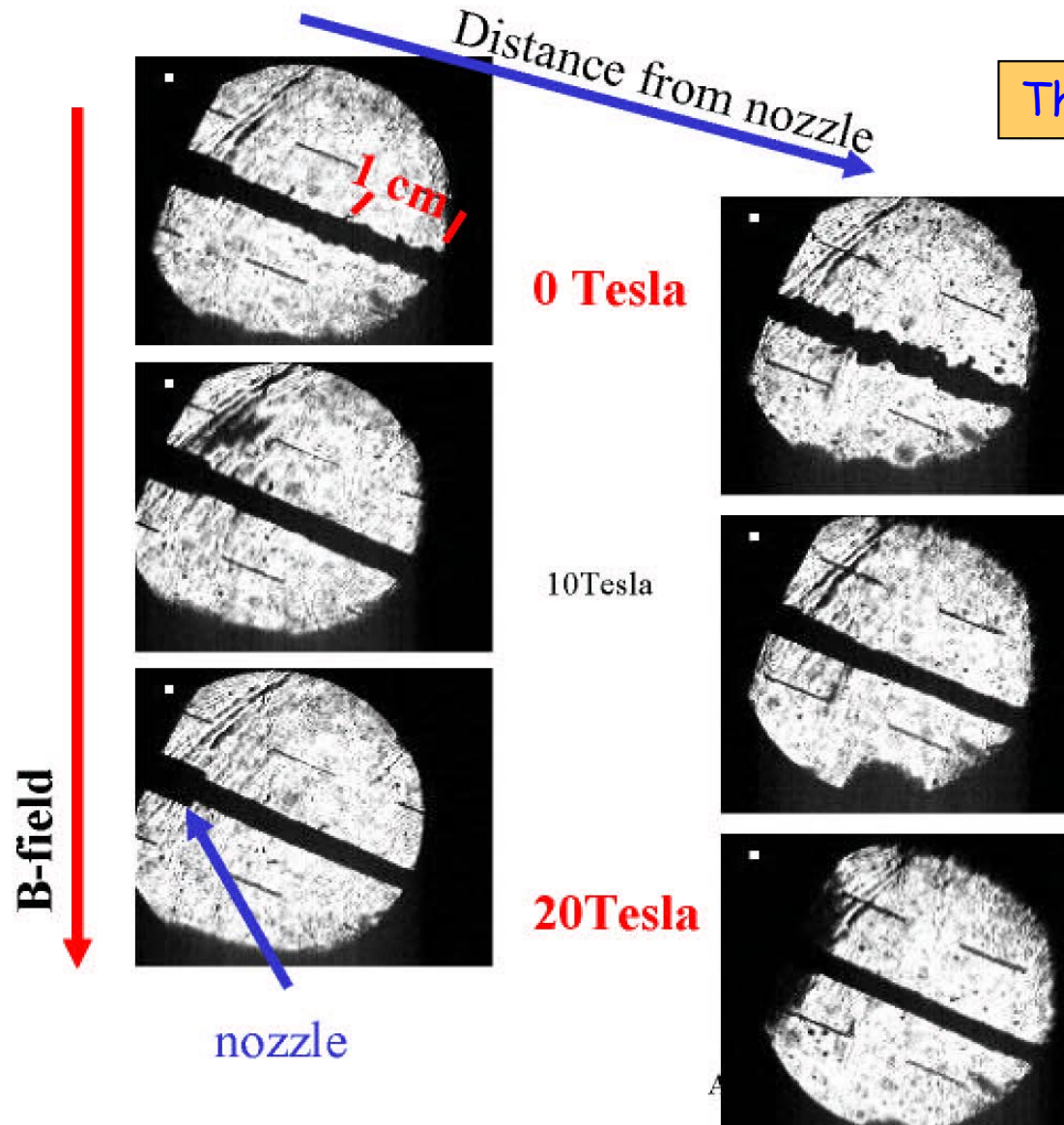

Thesis: A. Fabich (CERN)

This qualitative behaviour can be observed in all events.

Slide 5



Magnetic Damping of Jet Filamentation

Magnetic pressure suppresses (but does not eliminate) breakup of the Hg jet by the proton beam.

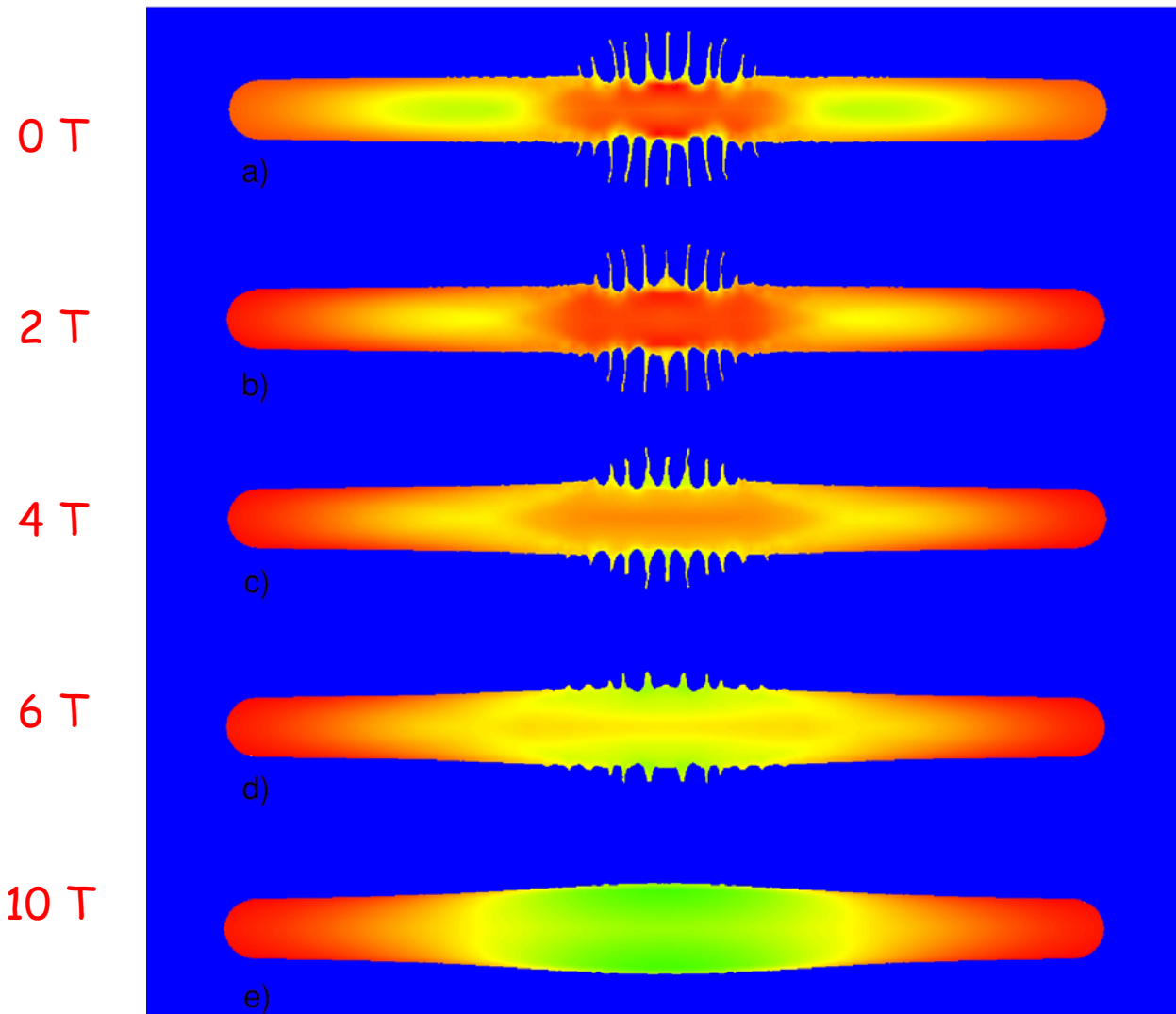

R. Samulyak (BNL) 10 T

Distortion of a Mercury Jet by a Transverse Magnetic Field

S. Oshima *et al.*, JSME Int. J. **30**, 437 (1987).

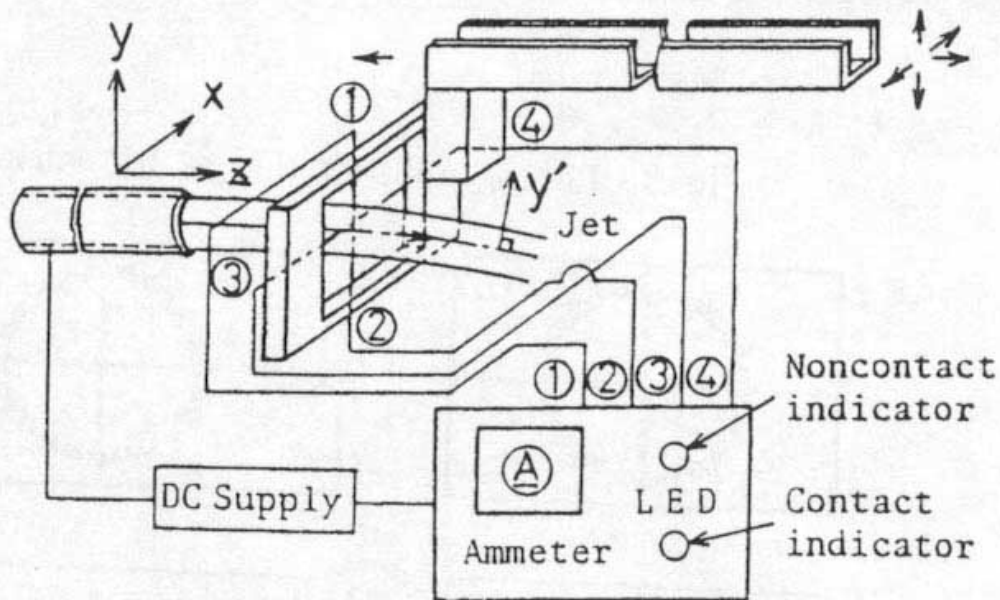

A 1-T transverse magnetic field caused severe quadrupole distortion of a 1-cm-diameter mercury jet.

Along a line at 100 mrad to a 20 T field the transverse field is 2 T.

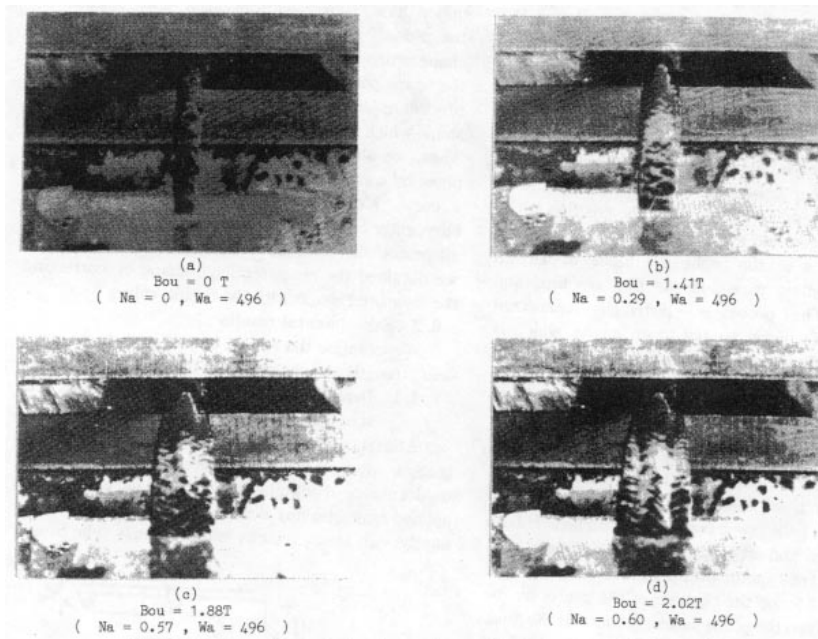

Fig. 9 Photographs of the jet for various applied magnetic field strengths

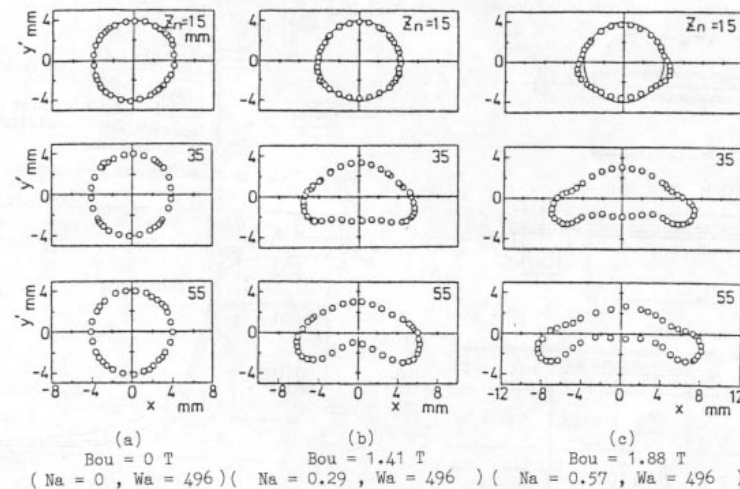
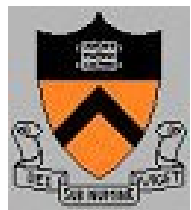

Fig. 10 Cross-sectional shape of the jet obtained by spot a electrode probe



Modeling of the Distortion of a Mercury Jet by a Magnetic Field

Quadruple distortion depends on nonuniformity of the transverse field (Gallardo *et al.*, 2002).

Simulations by Samulyak and by Morley confirm this behavior.

- ⇒ Reduce angle of jet to magnetic axis.
- ⇒ Place nozzle close to peak field region.
- ⇒ Reduce field nonuniformity.

Study 2: Nozzle in iron plug that smoothes upstream field.

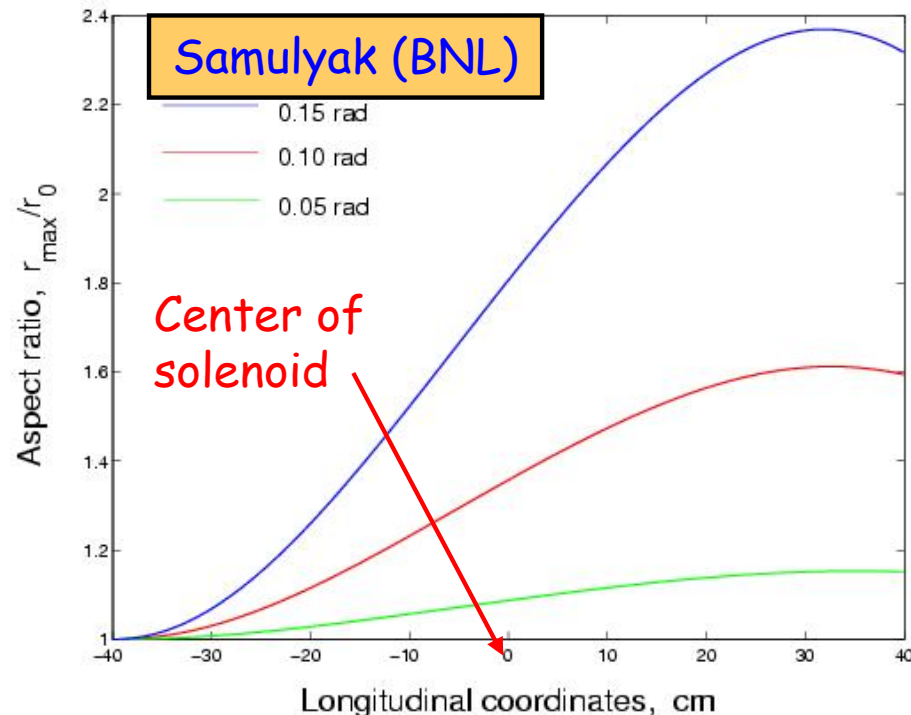

Morley: Jet at 100 mrad and 0, 20, 40, 60 cm from nozzle (which is 45 cm from magnet center).

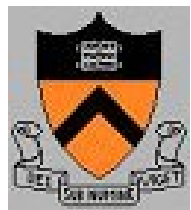
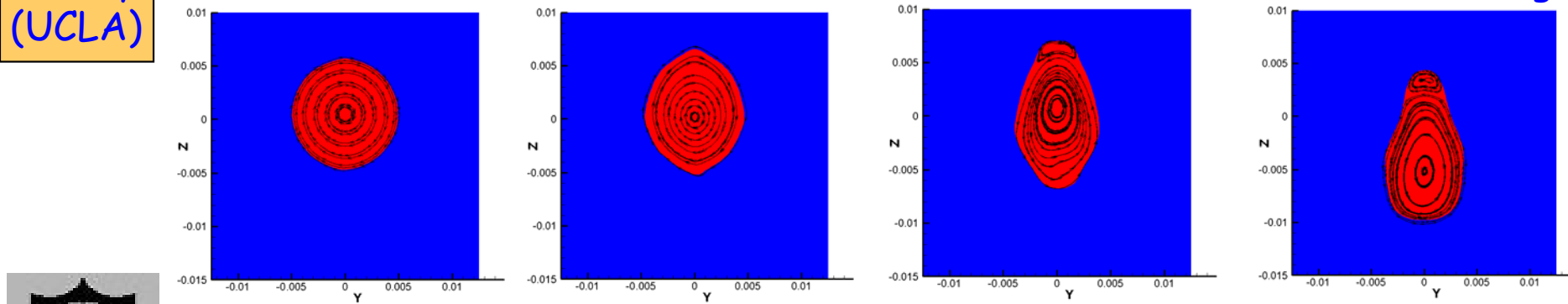

The MERcury Intense Target Experiment

CERN-INTC-2004-016
INTC-P-186
26 April 2004

Proposed: April 2004

Approved: April 2005

Formal name nToF11

A Proposal to
the ISOLDE and Neutron Time-of-Flight Experiments
Committee

Studies of a Target System for a 4-MW, 24-GeV Proton Beam

J. Roger J. Bennett¹, Luca Bruno², Chris J. Densham¹, Paul V. Drumm¹,
T. Robert Edgecock¹, Adrian Fabich², Tony A. Gabriel³, John R. Haines³,
Helmut Haseroth², Yoshinari Hayato⁴, Steven J. Kahn⁵, Jacques Lettry², Changguo Lu⁶,
Hans Ludewig⁵, Harold G. Kirk⁵, Kirk T. McDonald⁶, Robert B. Palmer⁵,
Yarema Prykarpatskyy⁵, Nicholas Simos⁵, Roman V. Samulyak⁵, Peter H. Thieberger⁵,
Koji Yoshimura⁴

Spokespersons: H.G. Kirk, K.T. McDonald
Local Contact: H. Haseroth

K. McDonald

NuFact08

3 July 2008



CERN nToF11 Experiment (MERIT)

The MERIT experiment is a proof-of-principle demonstration of a free mercury jet target for a 4-megawatt proton beam, contained in a 15-T solenoid for maximal collection of soft secondary pions.

MERIT = MERcury Intense Target.

Key parameters:

- 14 and 24-GeV Proton beam pulses, up to 16 bunches/pulse, up to 3.5×10^{12} p/bunch.
- σ_r of proton bunch = 1.2 mm, proton beam axis at 67 mrad to magnet axis.
- Mercury jet of 1 cm diameter, $v = 20$ m/s, jet axis at 33 mrad to magnet axis.
- \Rightarrow Each proton intercepted the Hg jet over 30 cm = 2 interaction lengths.

Every beam pulse is a separate experiment.

- ≈ 360 Beam pulses in total.
- Vary bunch intensity, bunch spacing, no. of bunches.
- Vary magnetic field strength.
- Vary beam-jet alignment, beam spot size.



MERIT @ CERN is Proof of Principle not Prototype

MERIT @ CERN used a 180° bend in the mercury delivery path because CERN would not permit any mercury-wetted connections to be made onsite.

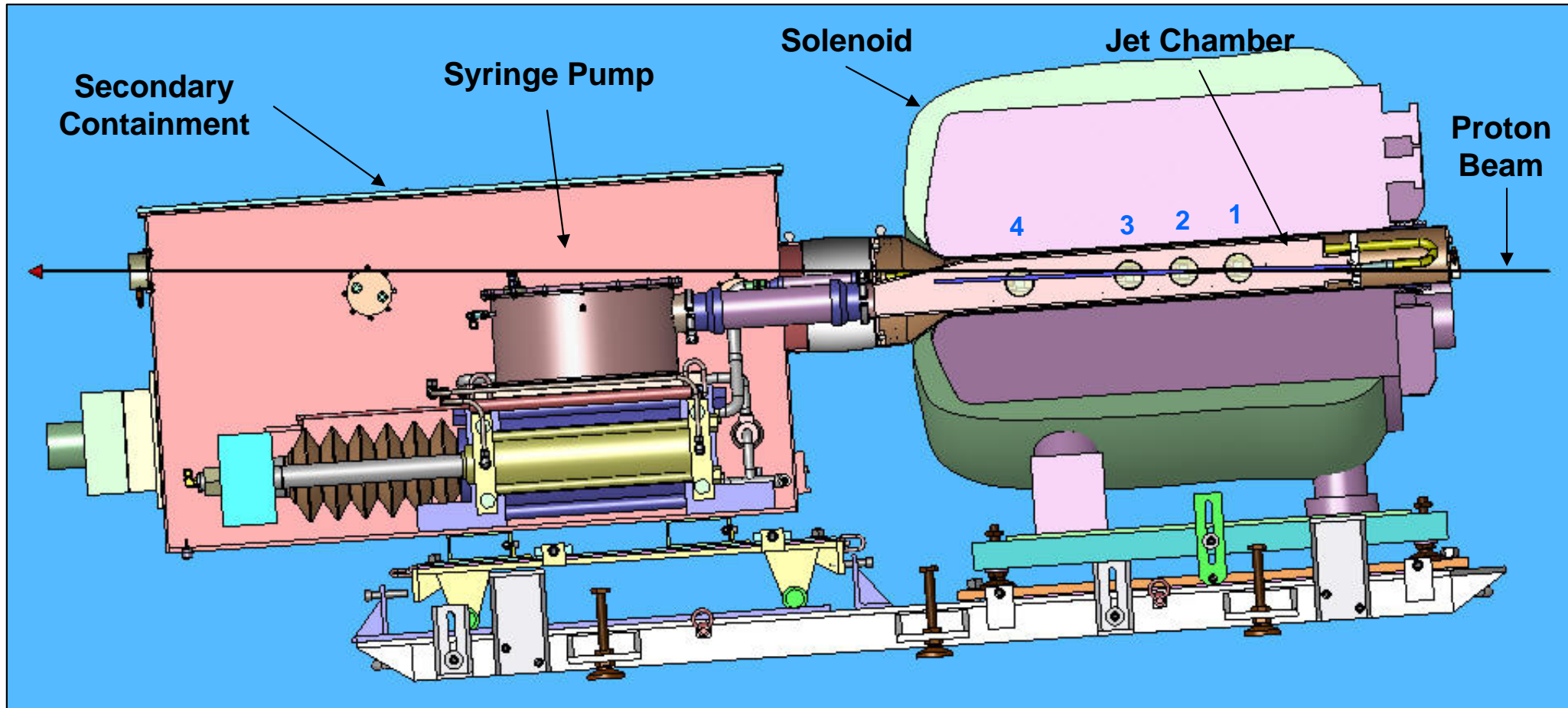

All Mercury Contained in the Primary Vessel

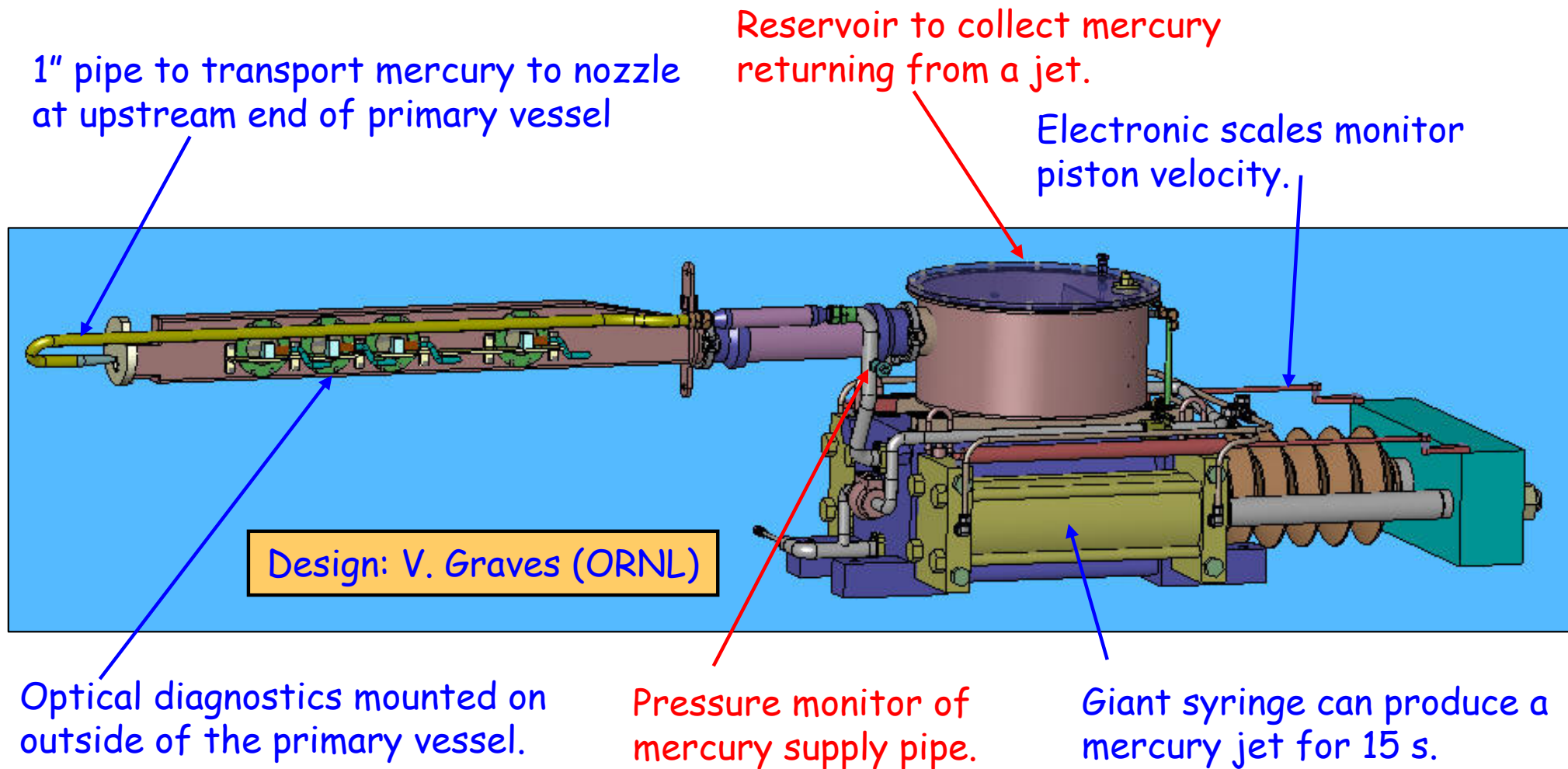

The primary vessel was not opened at CERN, other than for filling and emptying the mercury.

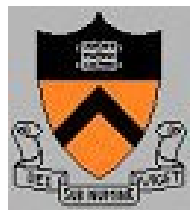

Secondary Containment of Mercury

Charcoal filters

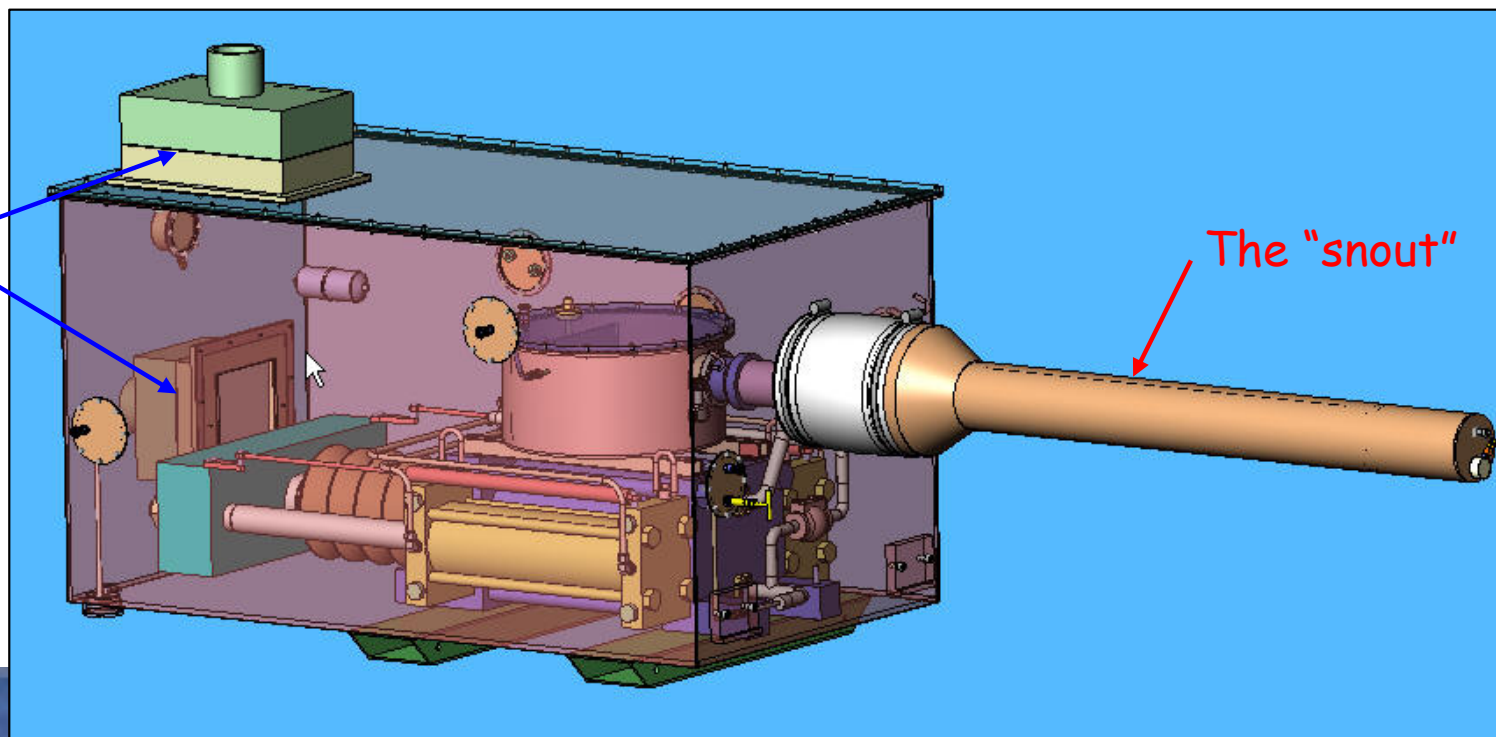
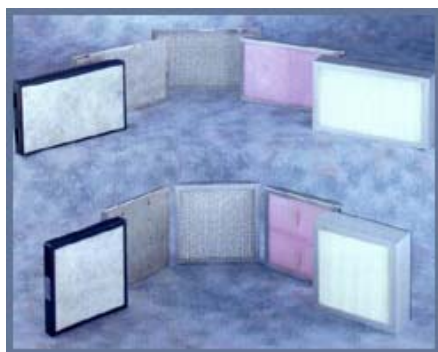

The secondary containment vessel was monitored for mercury vapor at all times with a VM3000 vapor monitor.

When the secondary containment vessel was opened for maintenance, a "Scavenger" with charcoal filters was used to capture any mercury vapors in the work area.



Beam Windows

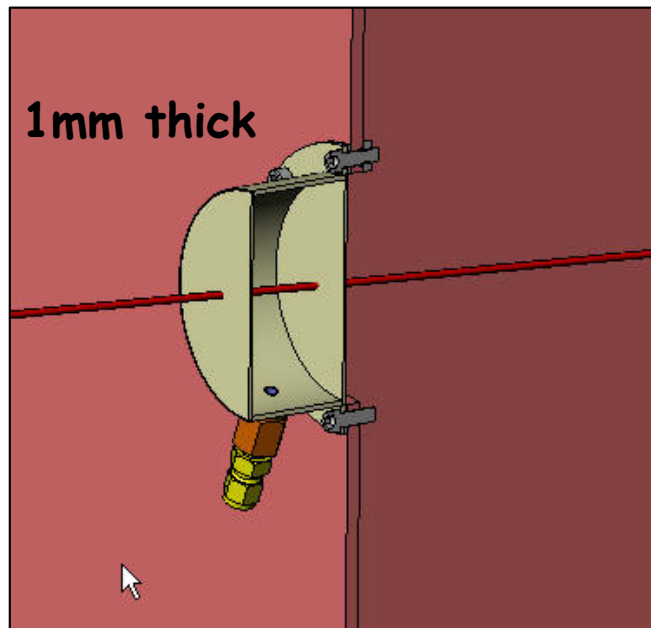
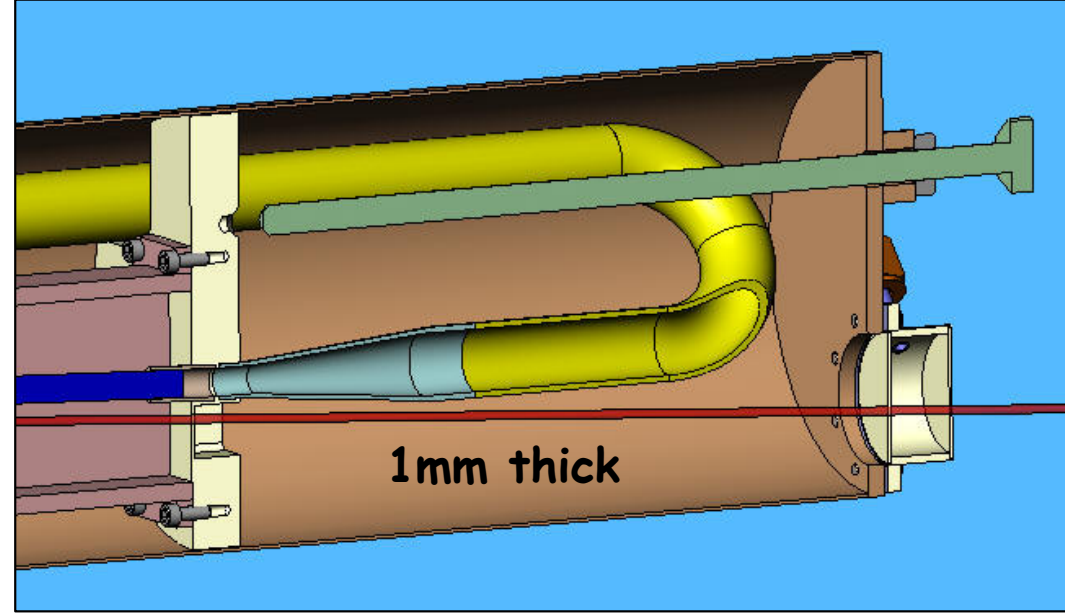
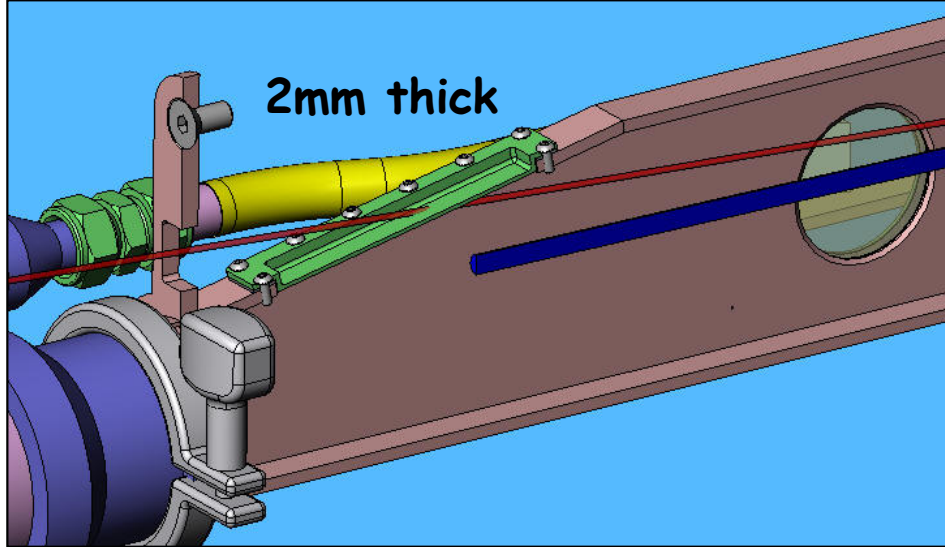

Windows made of Ti6Al4V alloy.

Single windows for primary containment, double windows for secondary.

Pressurize secondary windows, monitor to detect failure.

Optical Diagnostics via Fiberoptic Imaging

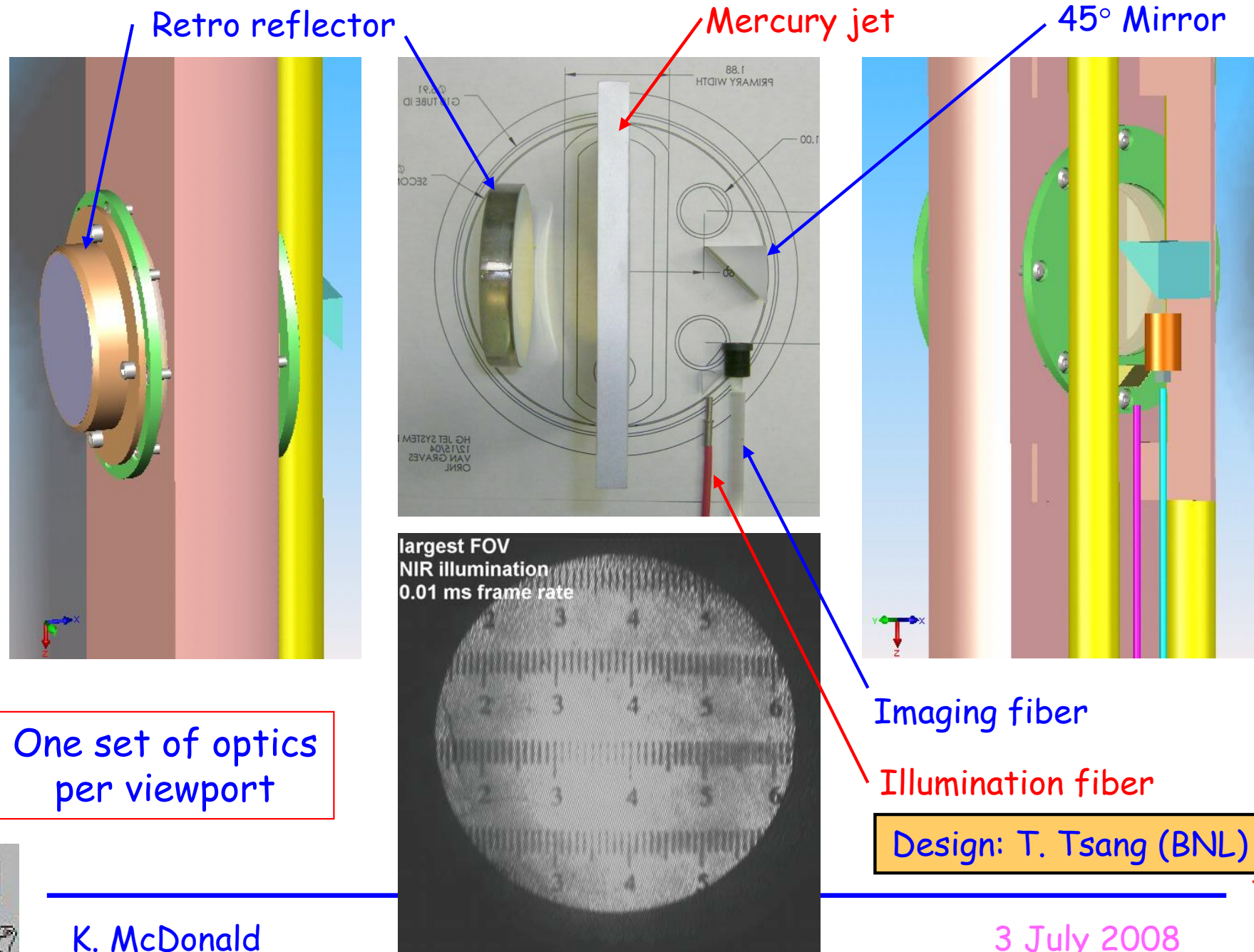

K. McDonald

3 July 2008

Section through the Primary Vessel at the Magnet Center

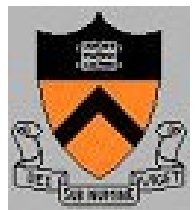
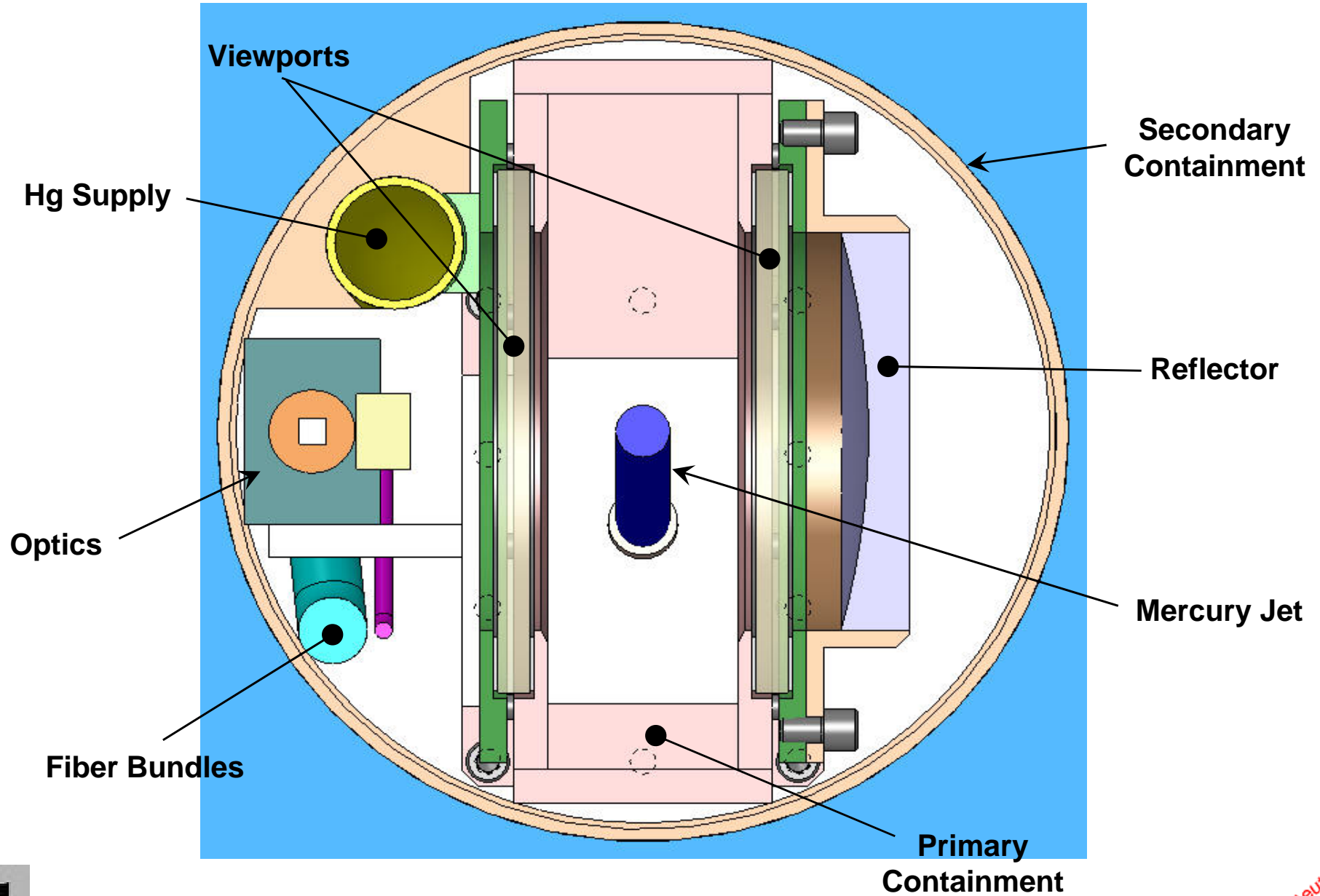

Four Highspeed Cameras View the Four Viewports

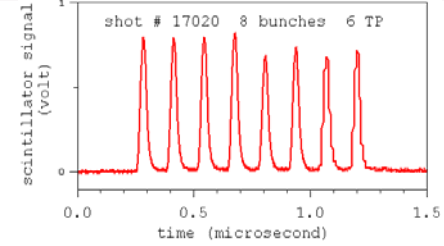
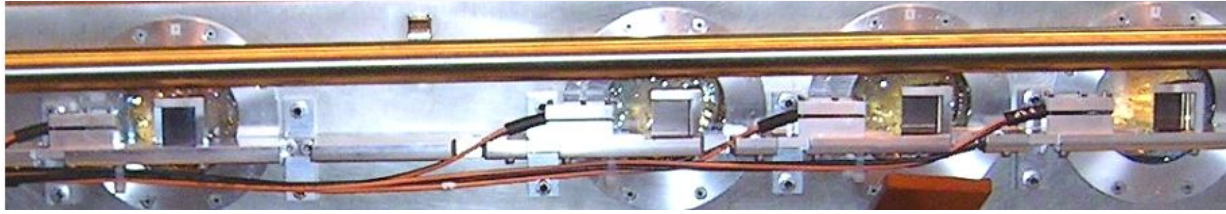
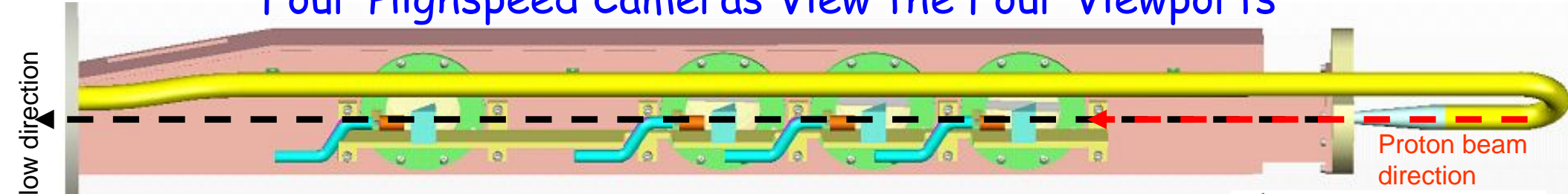

Viewport 4, Olympus
33 μ s exposure
160x140 pixels



Viewport 3, FV Camera
6 μ s exposure
260x250 pixels



Viewport 2, SMD Camera
0.15 μ s exposure
245x252 pixels

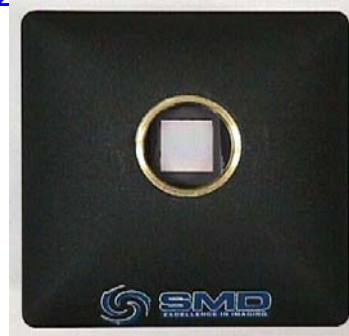

Viewport 1, FV Camera
6 μ s exposure
260x250 pixels



Nov. 11, 2007 Shot # 17020, 8 bunches, 6 TP, 7 Tesla, 15 m/s jet

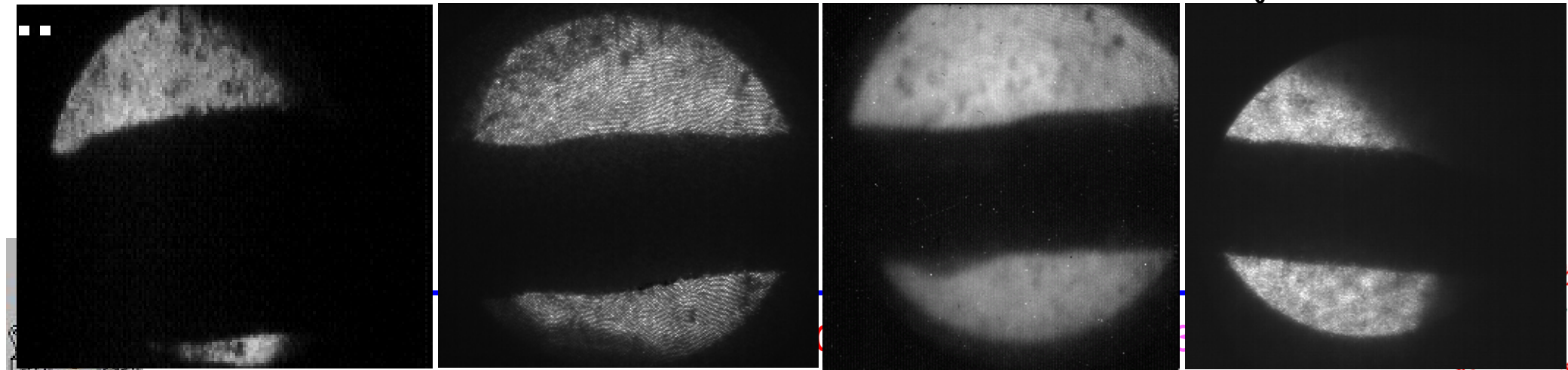

5 MW Power Supply

Recycled from the old SPS West Area extraction line.

30 MJ delivered during 15-s pulse.

⇒ Magnet temperature rises from 80 to 110K.

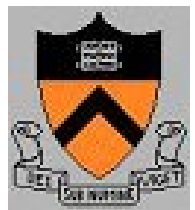
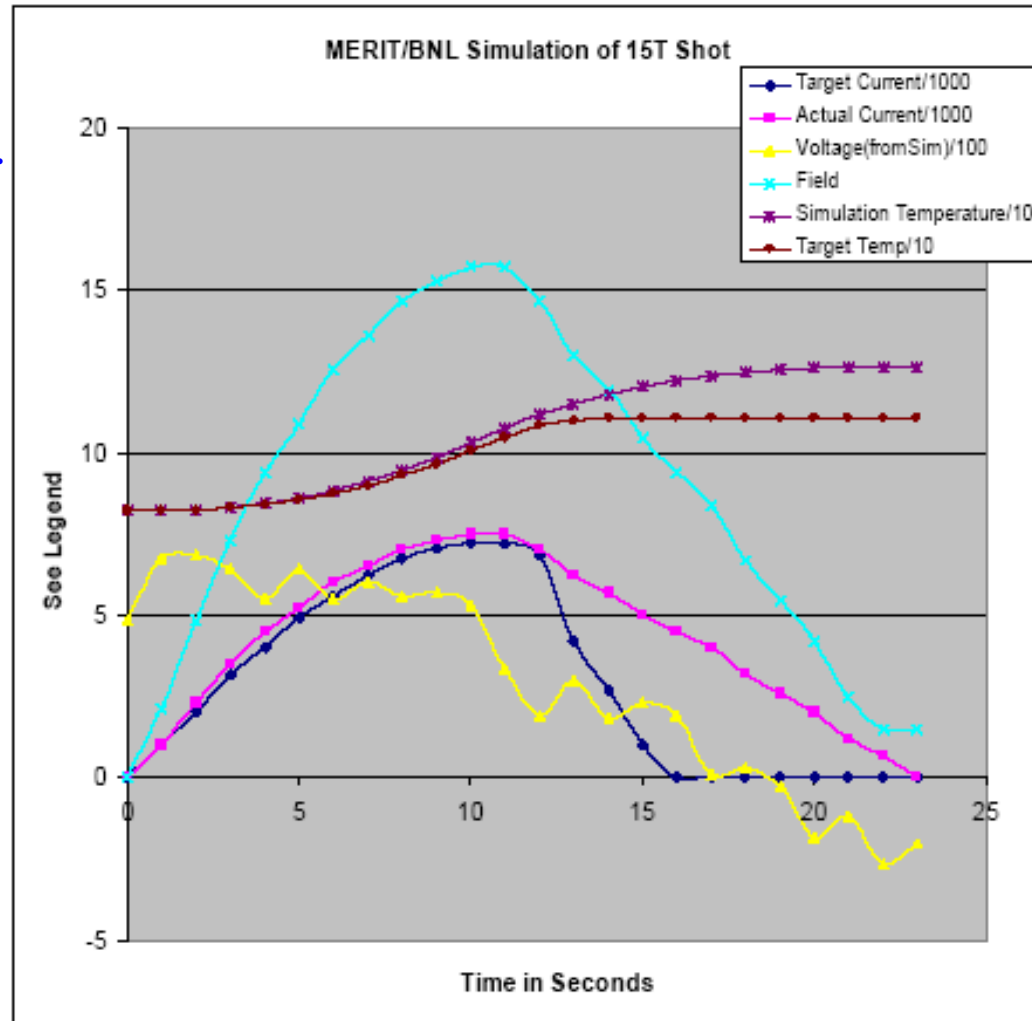

Magnetic Field Profile

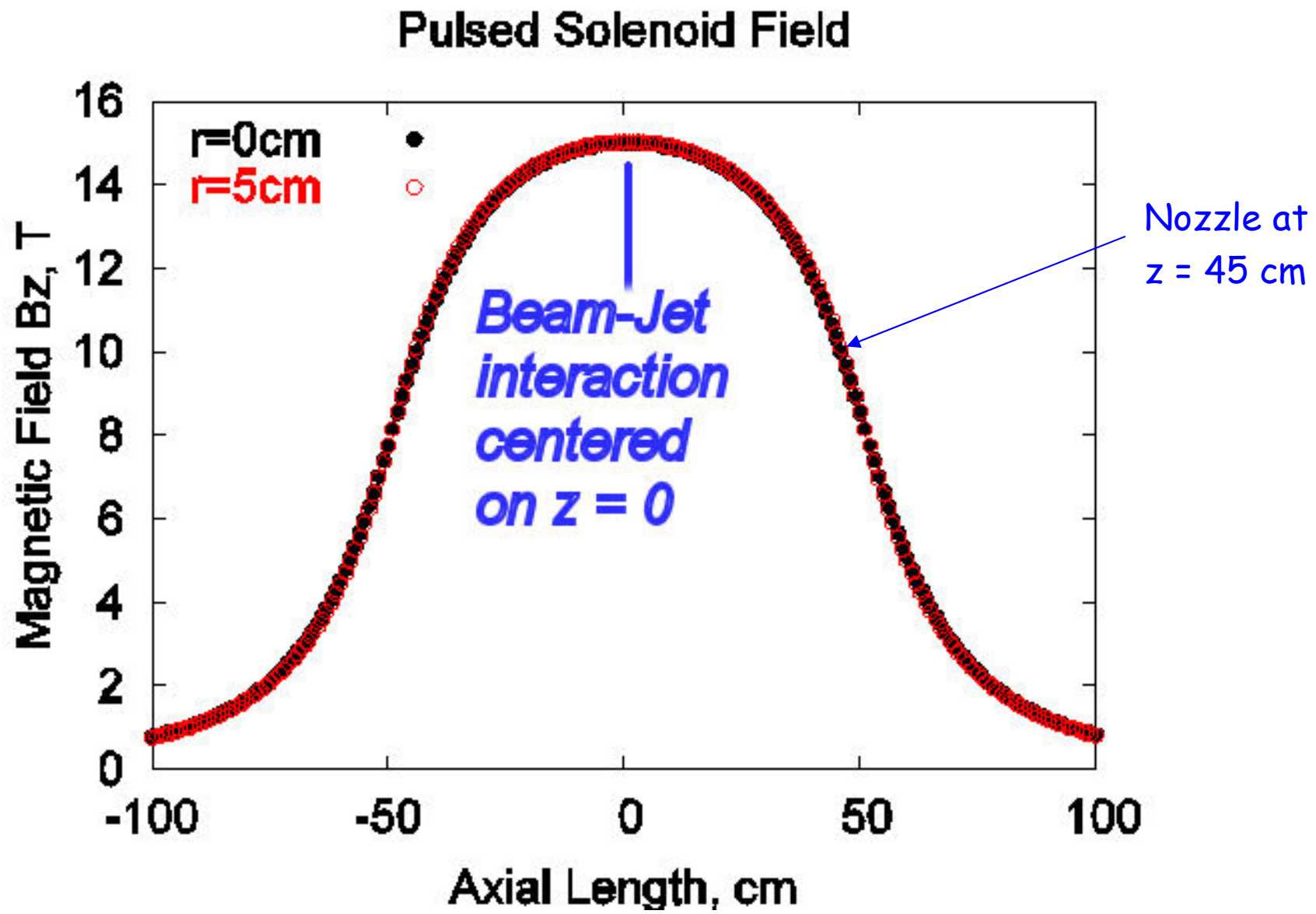

LN₂ Cryogenic System

Design: F. Haug, O. Pirotte (CERN)

Fabrication: AES (UK)

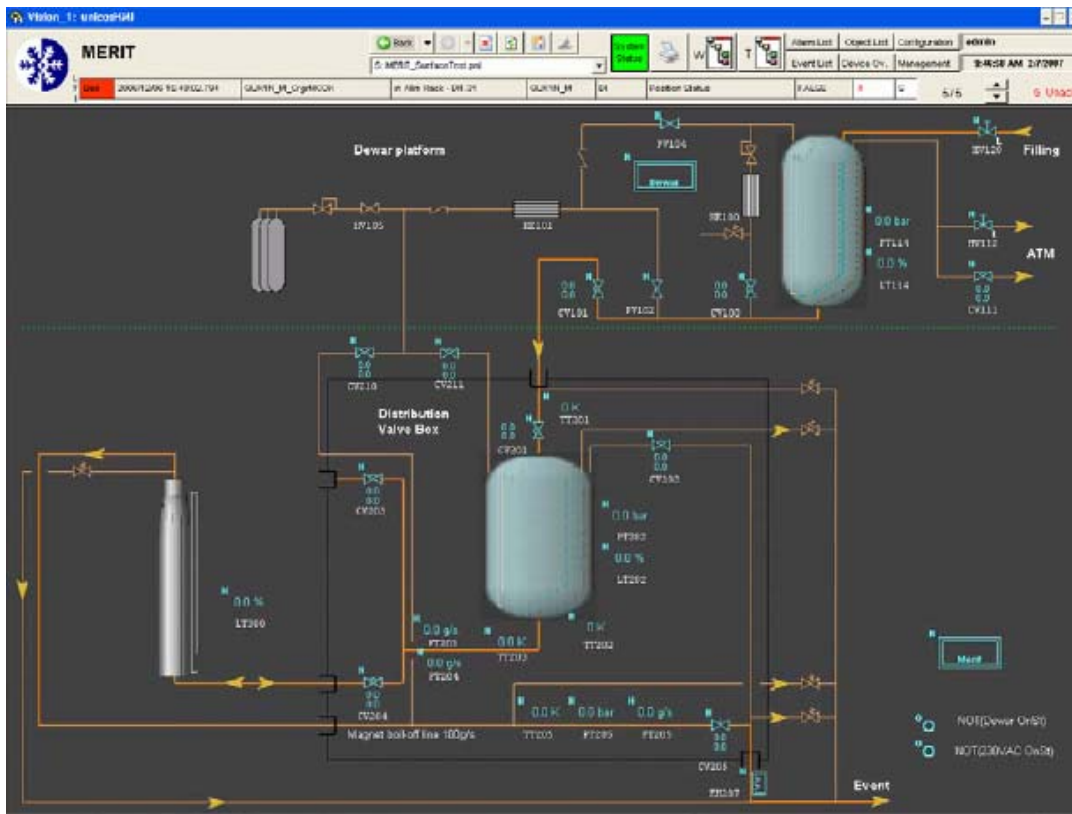

A 15-T pulse of the magnet deposited ≈ 30 MJ,
 \Rightarrow 30K increase in magnet temperature.
 ≈ 100 l of LN₂ needed to cool magnet back to 80K.
This took ≈ 40 min, which set the cycle time of the experiment.
LN₂ flushed from magnet during beam pulses to minimize activation of N₂ exhausted to room air.



Secondary Particle Detectors

PIN diode
 ~1-cm² active area,
 200 μm thick

pCVD Diamond
 7.5×7.5 mm² active area,
 300 μm thick

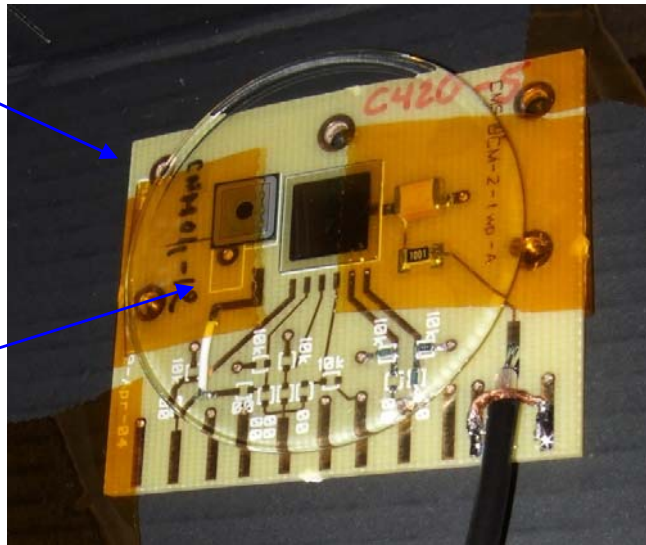

**ACEM
 detector**

**pCVD diamond
 + PIN diode**

**Particle fluxes - 3×10^{13} protons
 charged hadrons ($E > 200$ KeV)
 (MARS Simulation: S. Striganov)**

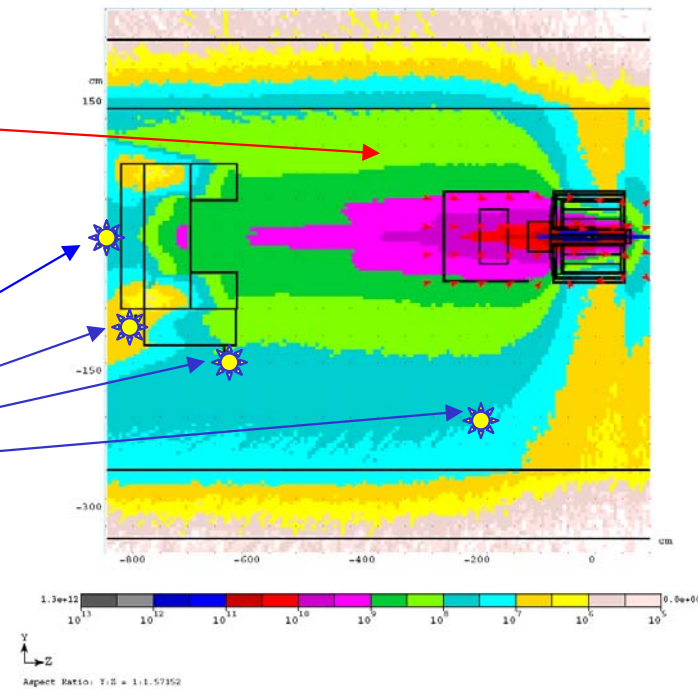

**I.Efthymiopoulos
 M. Palm (CERN)**

**Particle
 Detectors**

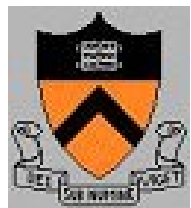

MERIT Locations at CERN

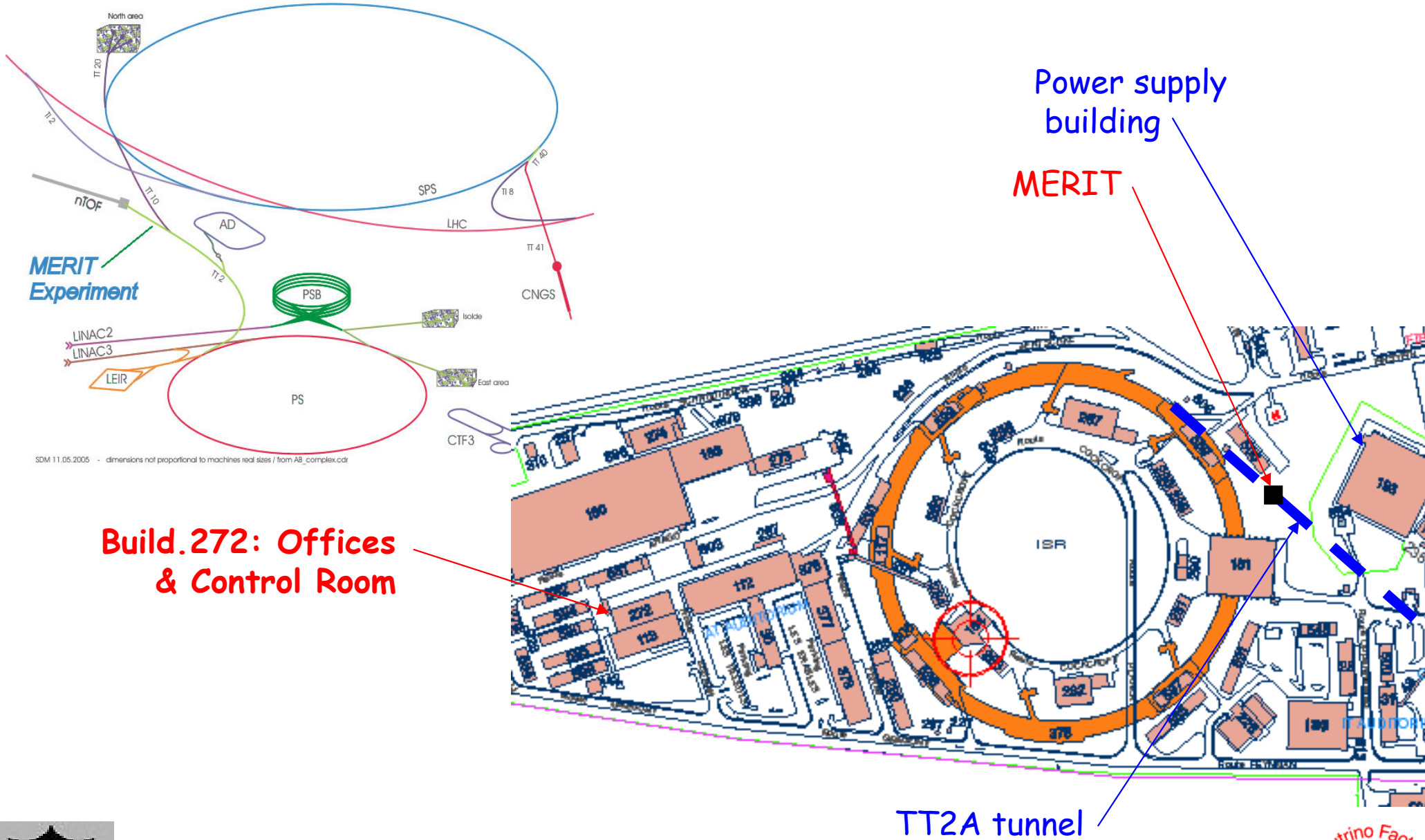

**Build. 272: Offices
& Control Room**

**Power supply
building**

MERIT

TT2A tunnel

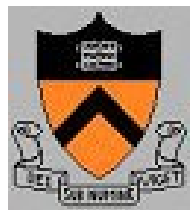

MERIT Layout in the TT2 and TT2A Tunnels

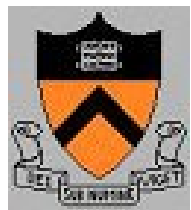
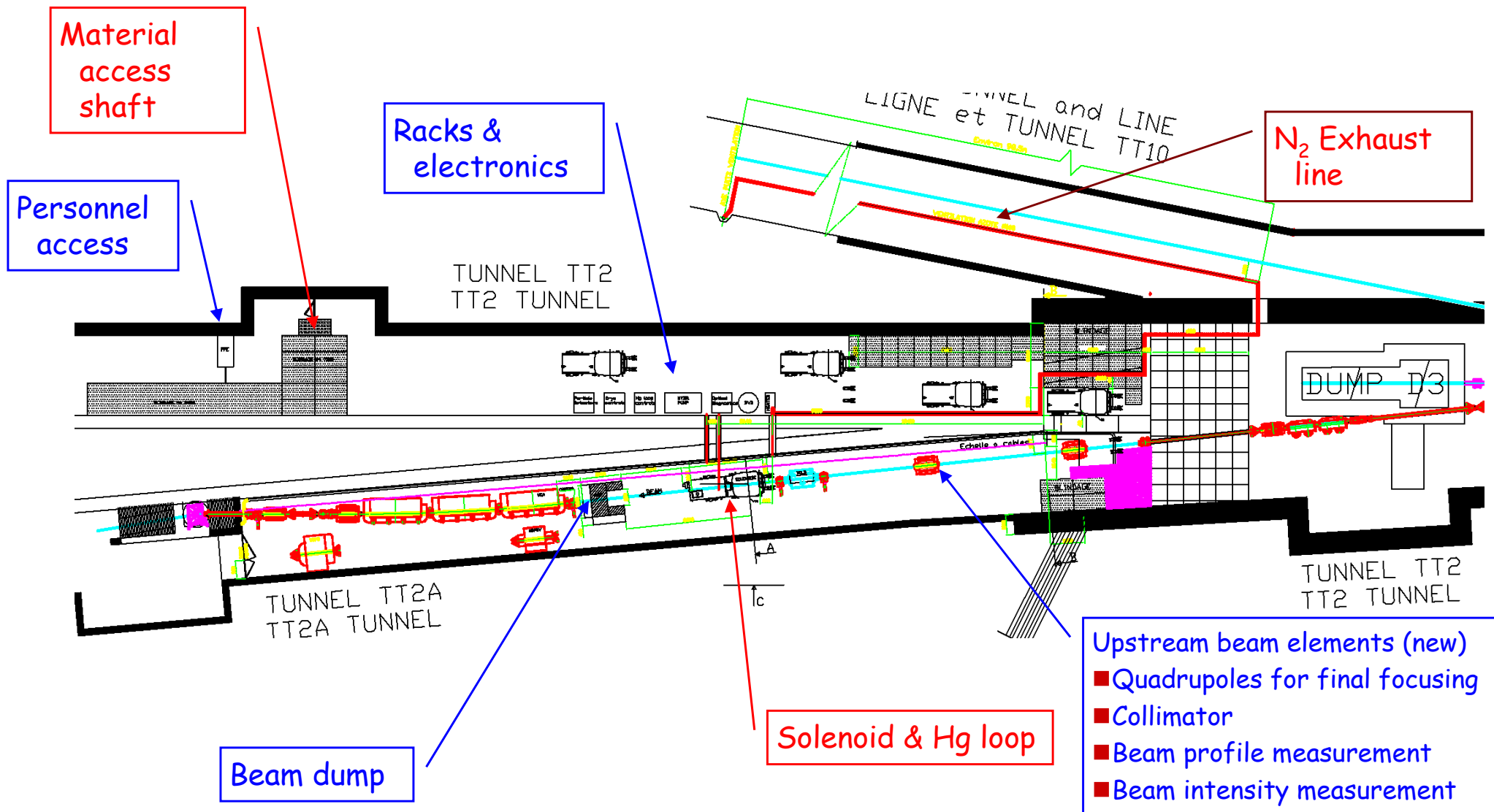

MERIT Layout in the TT2 and TT2A Tunnels

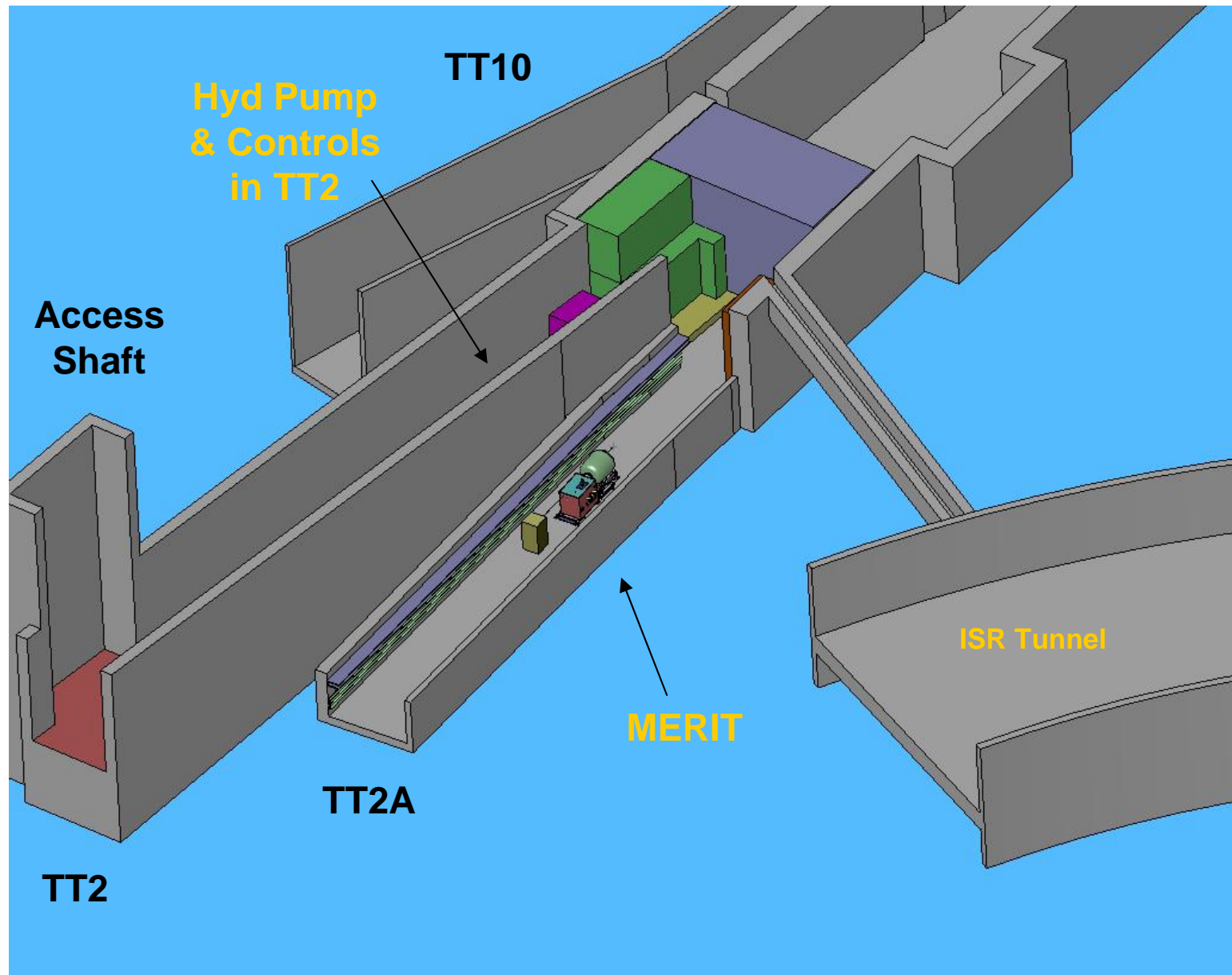

MERIT Installed in the TT2A Tunnel



K. McDonald

NuFact08

3 July 2008



MERIT Beam Pulse Summary

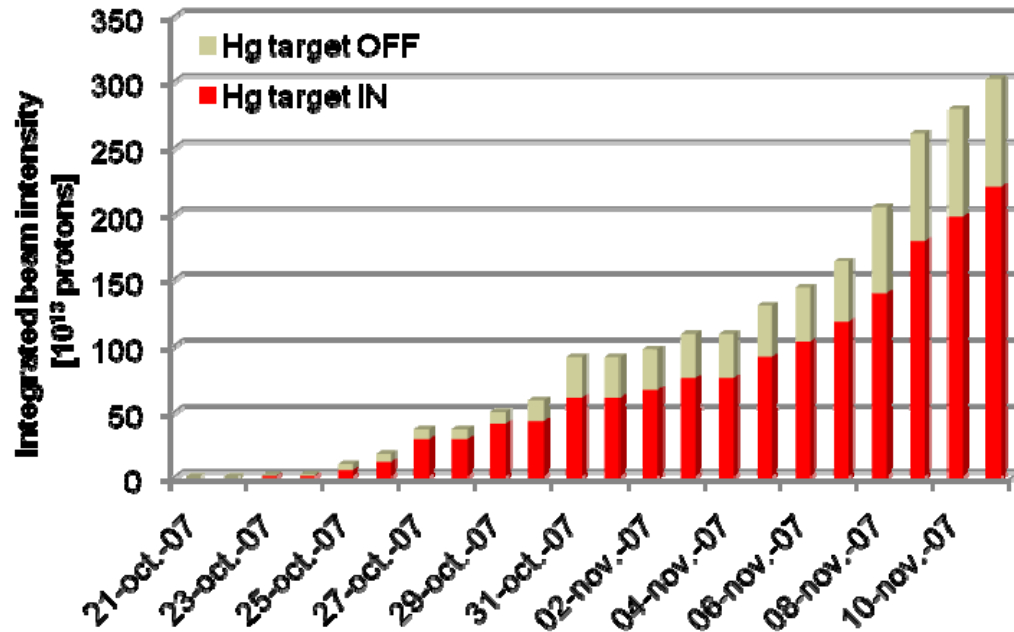

MERIT was not to exceed 3×10^{15} protons on Hg to limit activation.

30 Tp shot @ 24 GeV/c

- 115 kJ of beam power
- a PS machine record !

1 Tp = 10^{12} protons

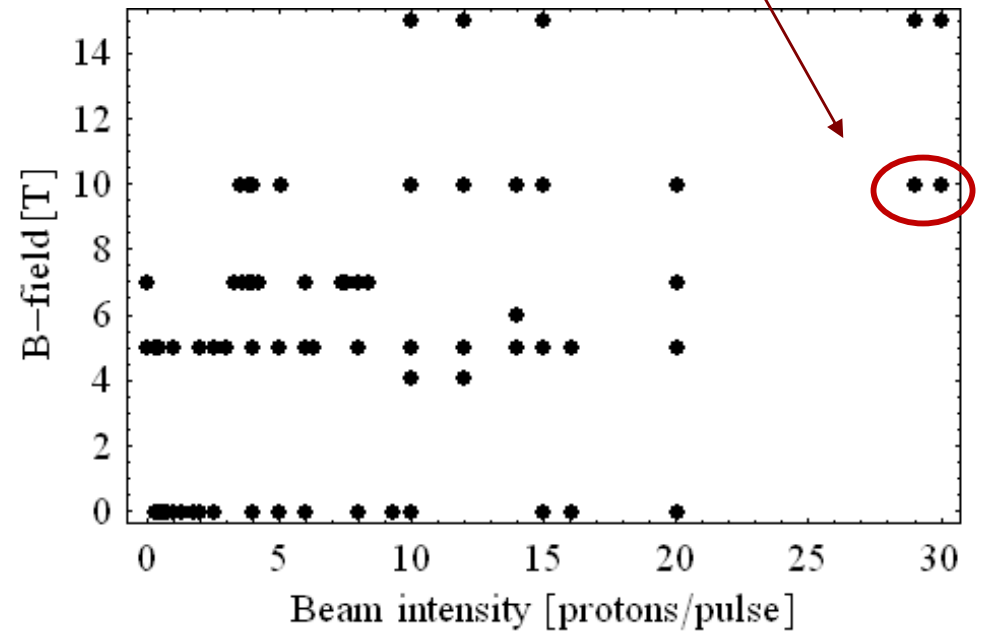

CERN nToF11 Experiment (MERIT), II

Data taken Oct.22 -- Nov.12, 2007 with mercury jet velocities of 15 & 20 m/s, magnetic fields up to 15 T, and pulses of up to 3×10^{13} protons in 2.5 μ s.

As expected, beam-induced jet breakup is relatively benign, and somewhat suppressed at high magnetic field.

"Pump-Probe" studies with bunches separated by up to 700 μ s are still being analyzed.

⇒ Good success as proof-of-principle of liquid metal jet target in strong magnetic fields for use with intense pulsed proton beams.

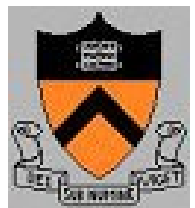

Geometry of the Beam-Jet Interaction

The proton beam enters the jet from below, and exits from above, about 30 cm downstream.

The camera on viewport 2 takes only 16 very high speed frames.

The cameras on ports 1, 3 and 4 took 200 frames at 2000 fps, \Rightarrow "movie" 1/10 s long.

A "movie" at viewport 3 sees the beam exiting the top of the jet first, and it entering the bottom of the jet \approx 100 frames later.

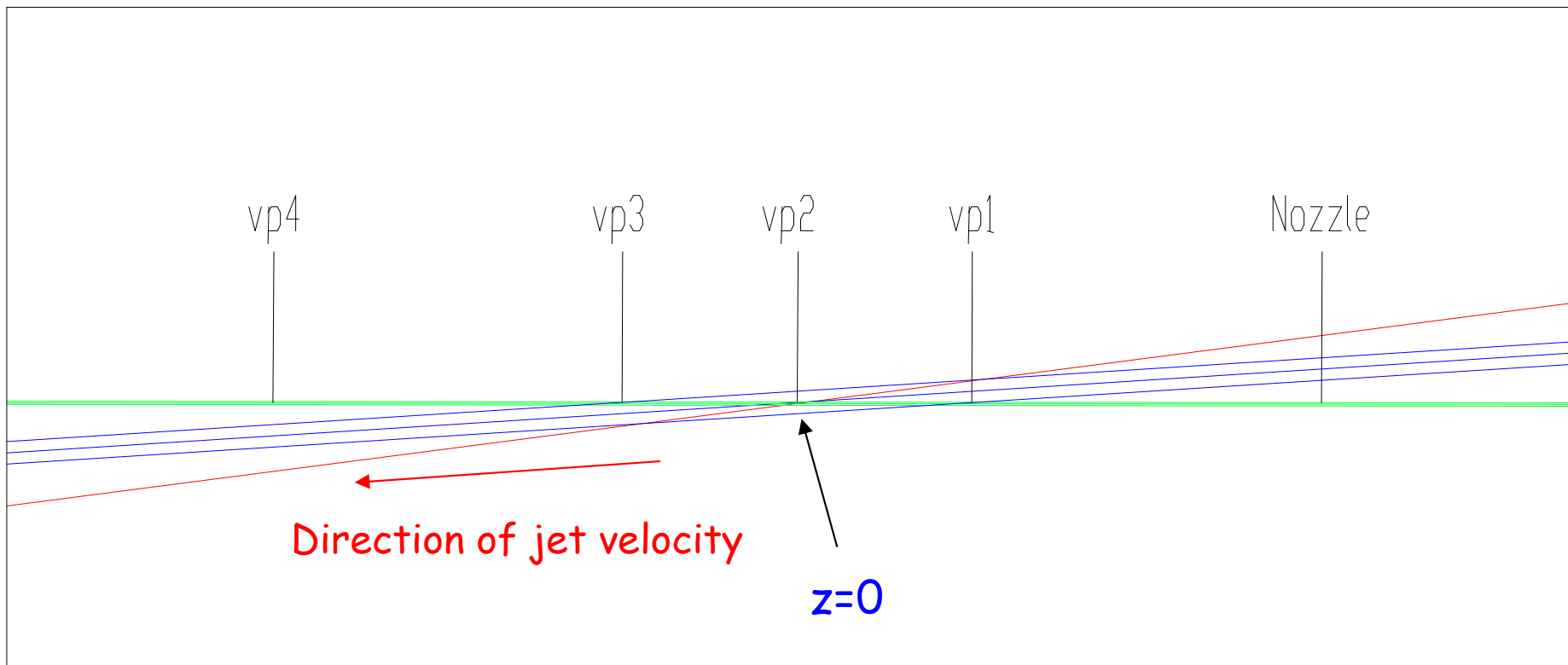

Magnet
Jet
Beam

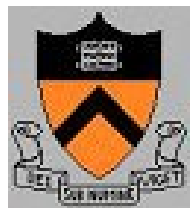

Jets of 15 m/s without Beam

0.4T

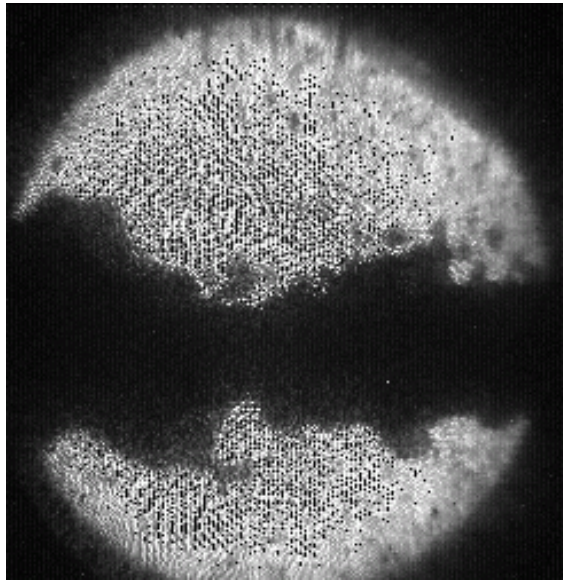

5T

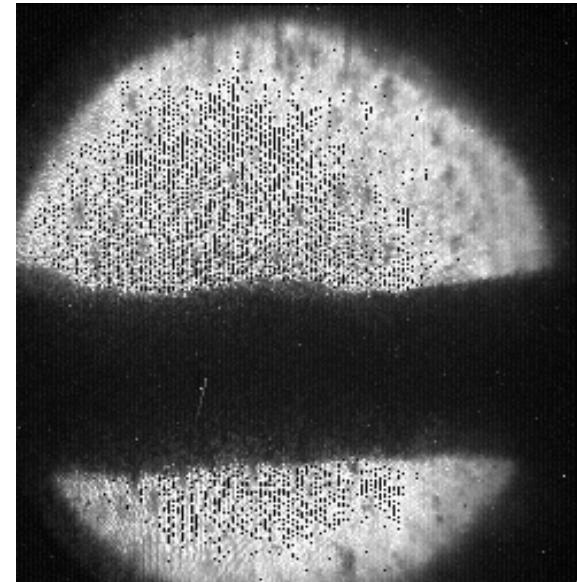

10T

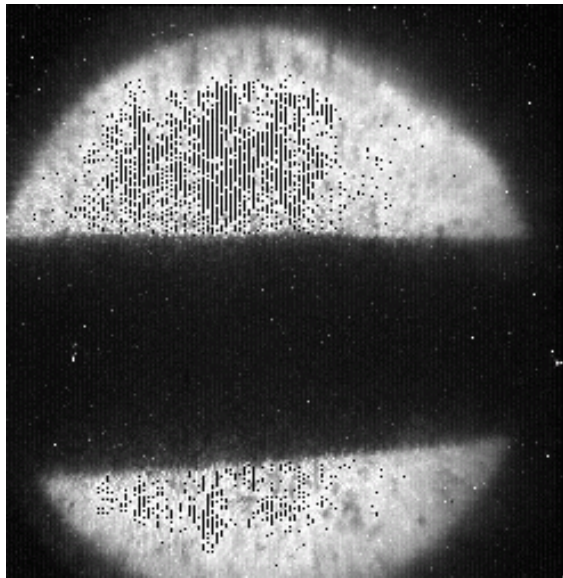

15T

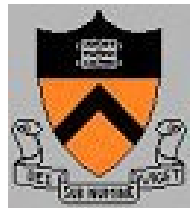
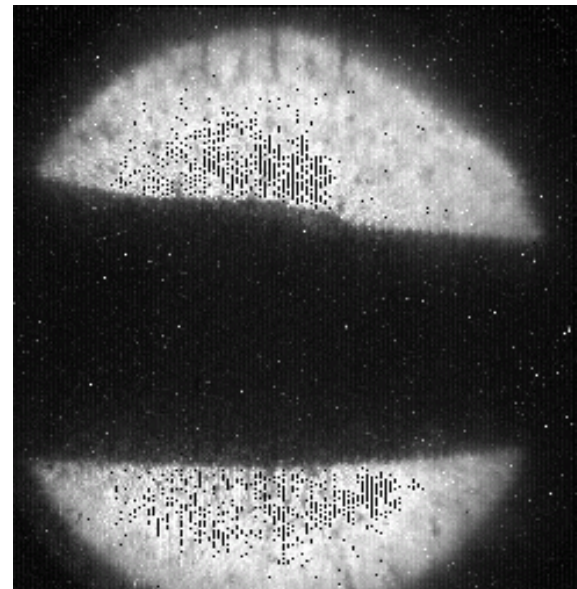

Jet Properties without Beam

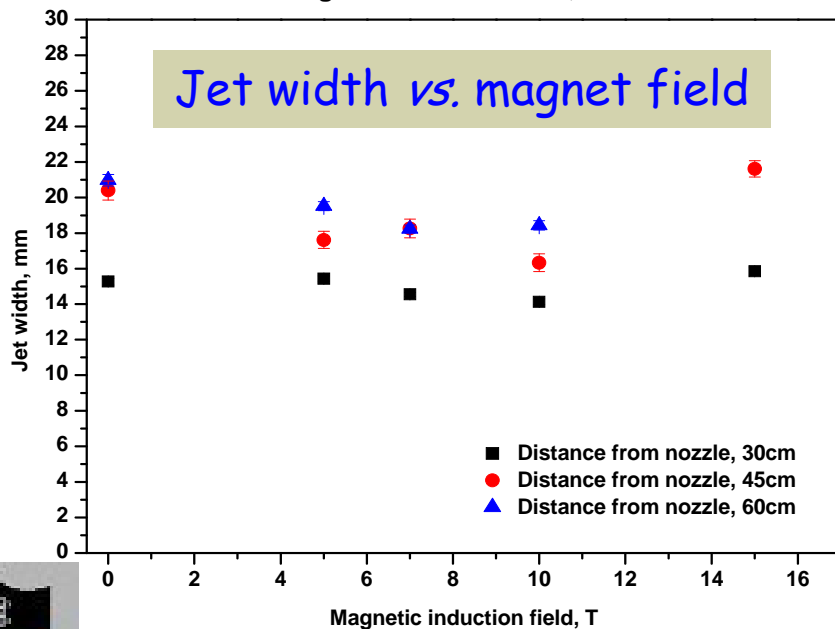
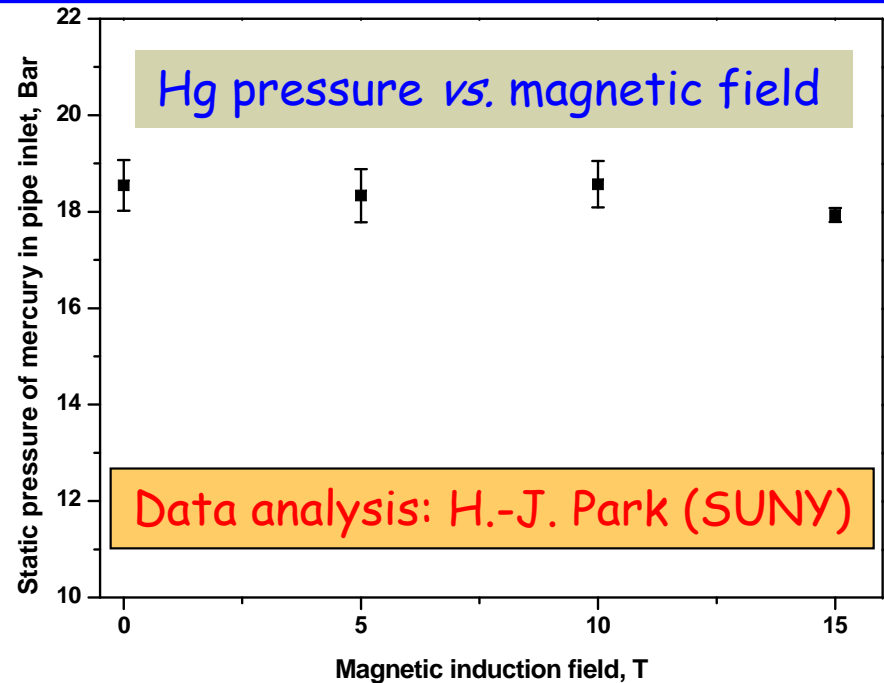
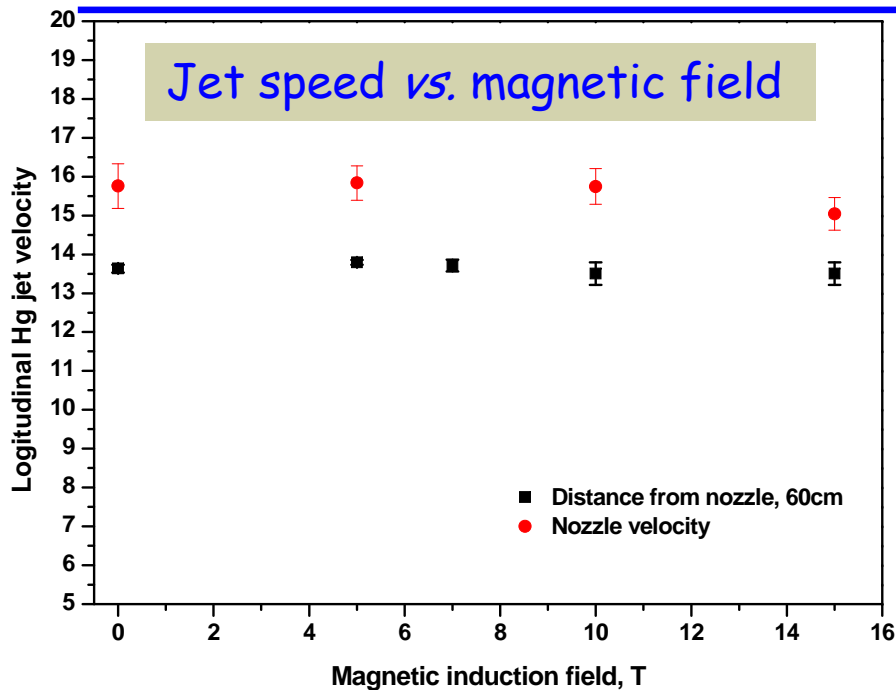

Jet velocity not noticeably reduced on entering magnetic field.

Pressure needed for $v = 15$ m/s does not increase with magnetic field.

Vertical height of jet not affected by magnetic field - but the height is \approx double the nozzle diameter.

"Typical" Interaction: 16 Tp, 5 T, 14 GeV/c, 15 m/s

Interaction
Center

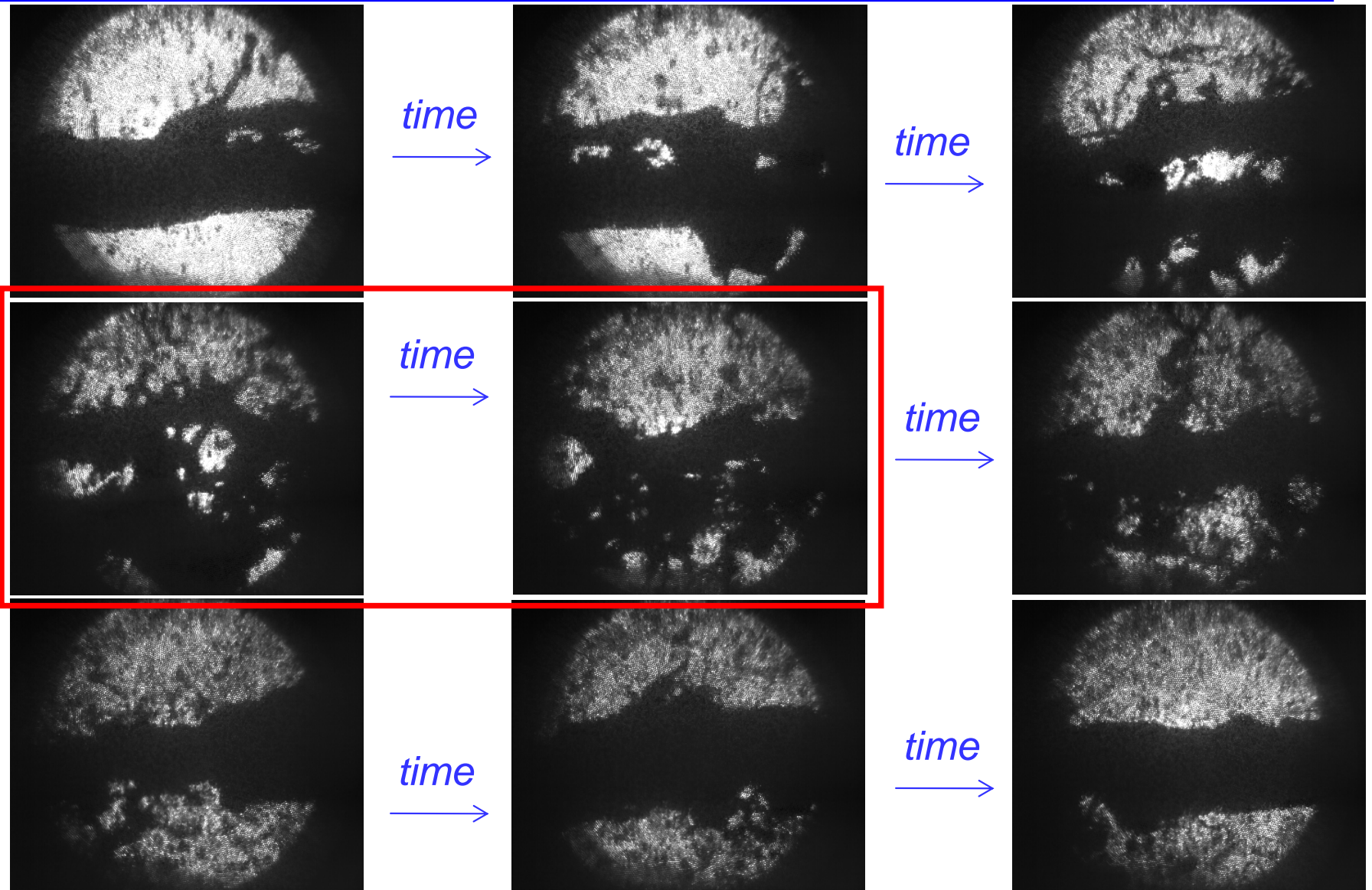

Note disruption of top of jet at early times, and of bottom at later times.

"Disruption length" inferred from number of frames the disruption lasts.

Jet Breakup Velocity Observed at Port 2 with Fast Camera

3.8TP, 10T

$V = 24 \text{ m/s}$

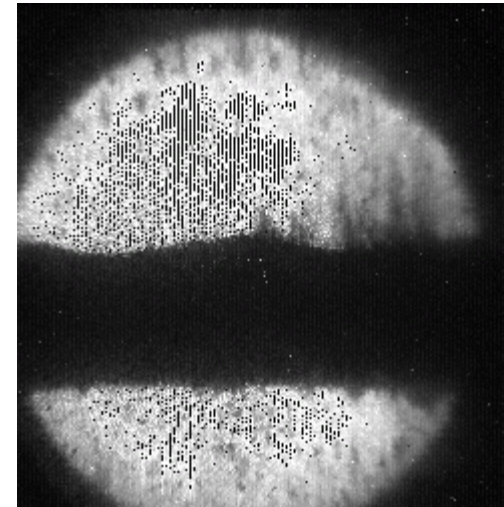
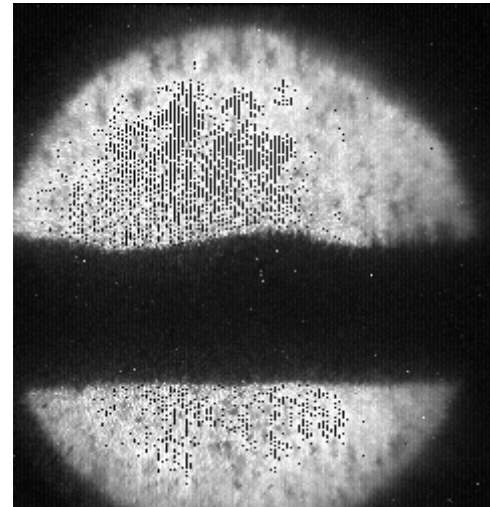
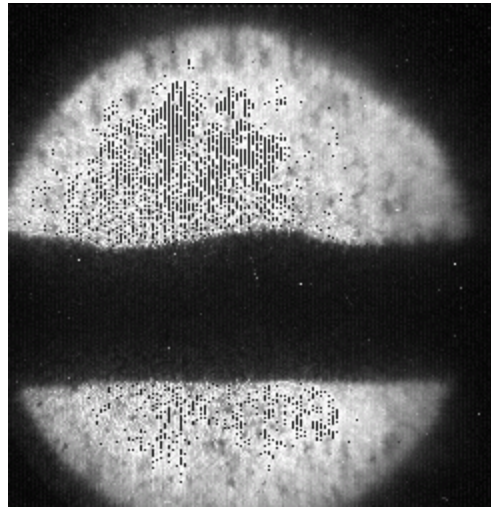
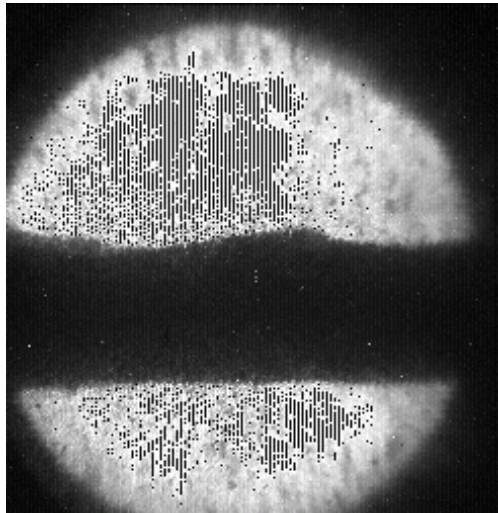

$t = 0$

$t = 0.150 \text{ ms}$

$t = 0.175 \text{ ms}$

$t = 0.375 \text{ ms}$

10TP, 10T

$V = 54 \text{ m/s}$

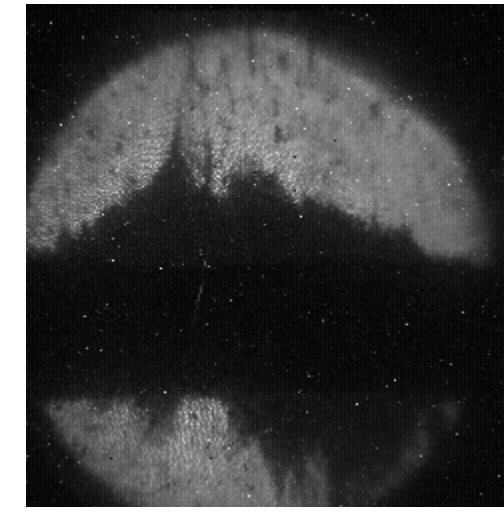
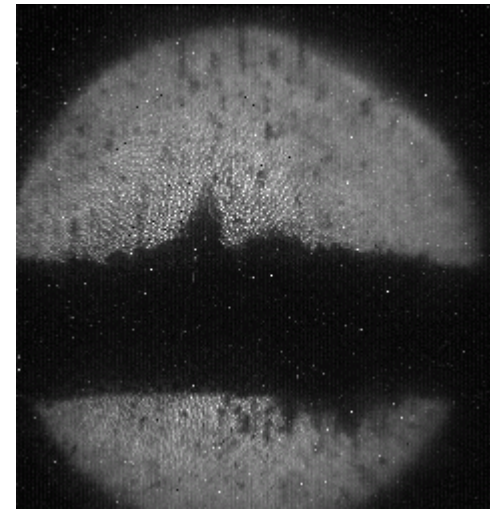
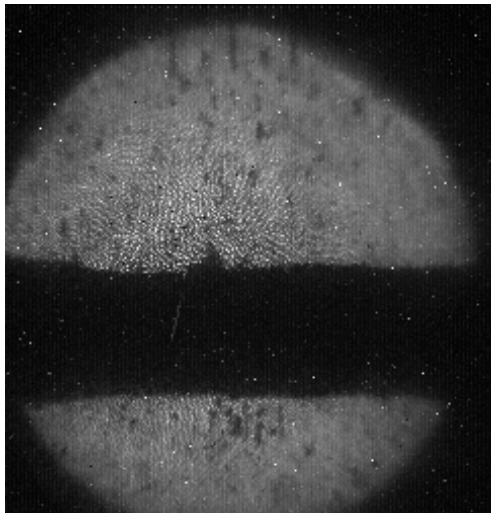
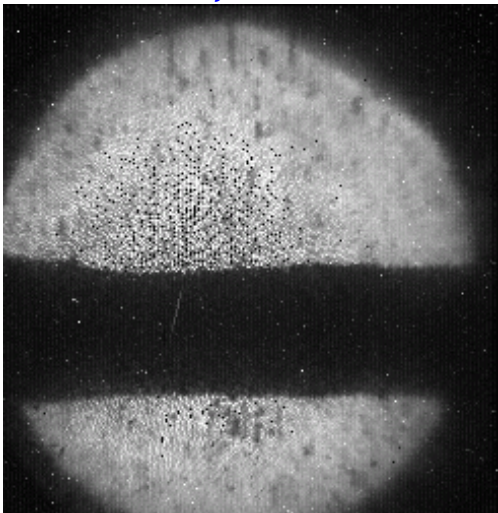

$t = 0$

$t = 0.075 \text{ ms}$

$t = 0.175 \text{ ms}$

$t = 0.375 \text{ ms}$

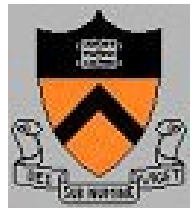

K. McDonald

NuFact08

3 July 2008



Jet Breakup Velocity Measurements

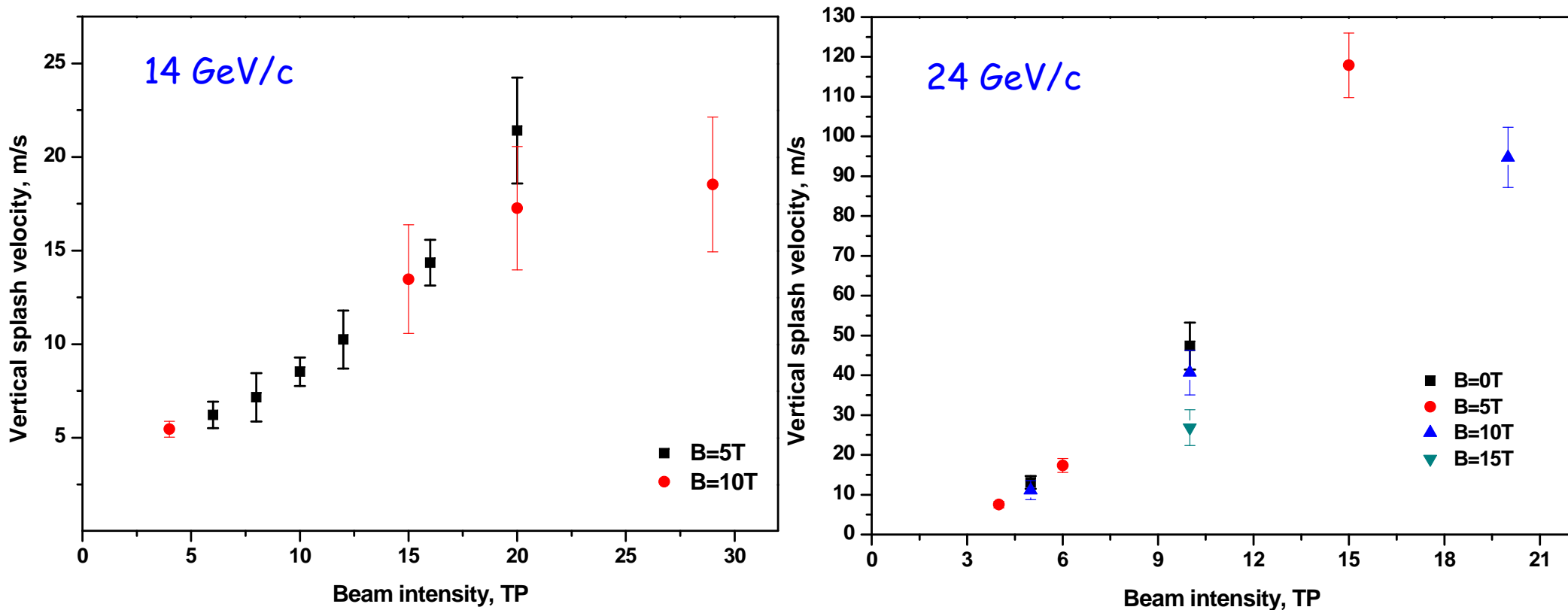

Beam spot area at 24 GeV/c is (14/24) of that at 14 GeV/c.

Beam intensity = energy/cm² is (24/14)² ≈ 3 times greater at 24 than at 14 GeV/c.

Measurements are consistent with model that breakup velocity ∝ beam intensity.



Pump-Probe Studies via Extraction Gymnastics

Example: Operate PS at harmonic 16, fill only bunches 1-6 and 11-12.

Extract bunches 1-6 first, and then bunches 11-12 N turns later.

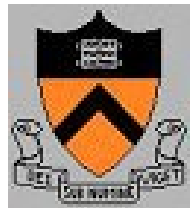
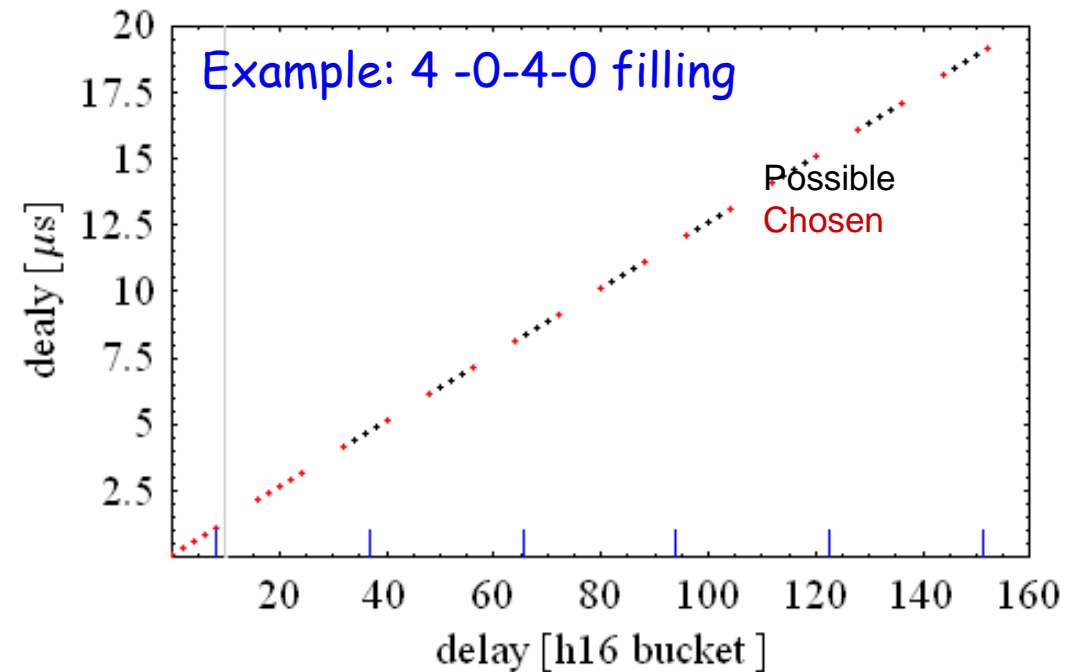
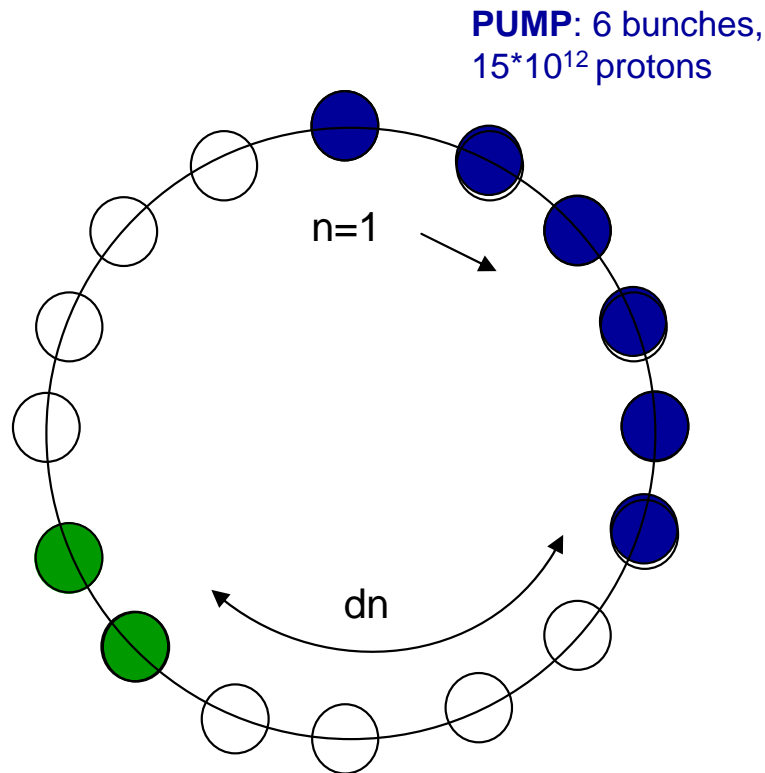

Pump-Probe Study with 4 Tp + 4 Tp at 14 GeV/c

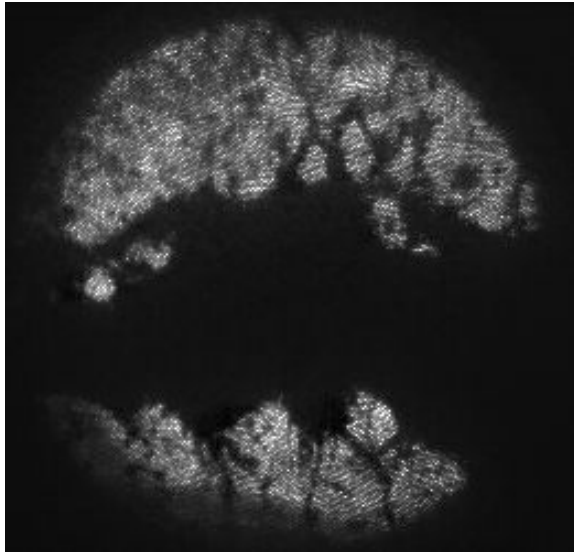

Single-turn extraction
→ 0 delay, 8 Tp

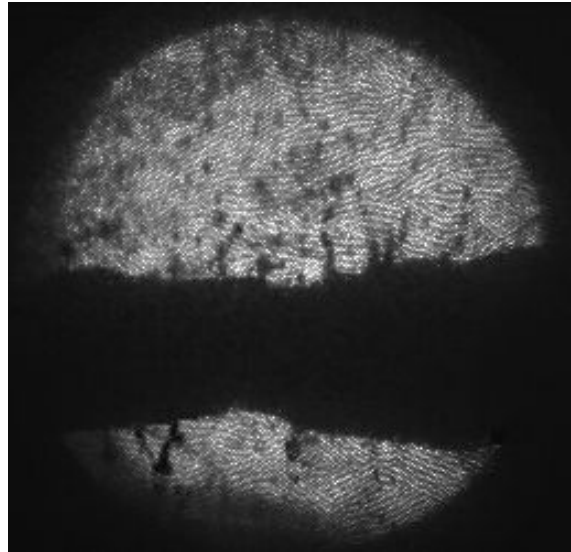

4 Tp probe extracted
on subsequent turn
→ 3.2 μs delay

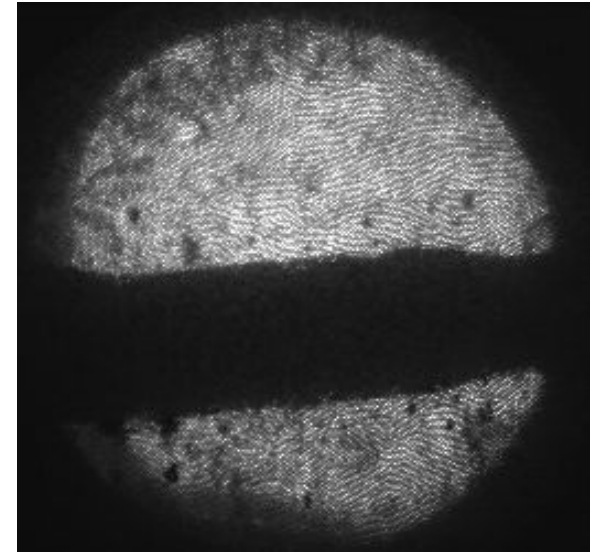

4 Tp probe extracted
after 2nd full turn
→ 5.8 μs Delay

Target supports 14-GeV/c, 4 Tp beam at 172 kHz rep rate without disruption.

Preliminary analysis of studies at 14 GeV/c with 15 Tp pump and 5 Tp probe with delays of 2-700 μs indicate little change in secondary particle production by probe.
⇒ Initial breakup of jet does not reduce particle production immediately.
⇒ May be able to use bunch trains of several-hundred μs length.

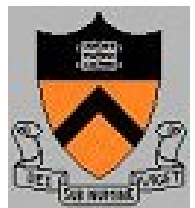

Summary of MERIT Analysis to date

Jet velocity, shape and delivery pressure little affected by magnetic field.

Jet surface instabilities are reduced at higher magnetic field.

Jet height is larger than expected, perhaps an effect of the 180° bend upstream of the nozzle.

Jet disruption velocity scales with beam intensity, and is not destructive.

Jet disruption length is less than length of beam overlap with the jet.

Jet disruption length and velocity are reduced at higher magnetic field.

There is no jet disruption for pulses of less than 1 T_p (or higher in higher magnetic field).

Bunches more than 5 μs apart act separately in causing disruption.

While visible disruption begins 50 μs after a proton pulse, secondary particle production is the same for pulses that follow at several times this value.

In sum, the MERIT experiment provides a proof of principle of a mercury jet target in a high-field solenoid for multimegawatt proton beams.

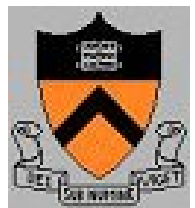

Post-MERIT Liquid Target Issues

MHD simulations

Optimize performance of nozzle in Fe plug

Eliminate 180° bend

Splash in liquid pool beam dump

Particle production

Rep-rate delay limits

Use of a Pb-Bi alloy rather than Hg

Target station engineering

Study these issues in context of IDS/MCFS



Issues from MERIT: Jet Quality, Vertical Height

Jet quality poor in zero magnetic field, and improves (as expected) with increasing field.

Jet vertical height 1.5-2.4 times nozzle diameter, and little affected by magnetic field.

Simulations predict that vertical expansion of jet would be small, and would vary as B^2 .

Suggests that 180° bend before nozzle leads to vertical expansion of jet.

Interesting hydrodynamic issues, but may be best to focus of aspects relevant to ν Factory/Muon Collider - where no 180° bend is contemplated.

0 T

10 T

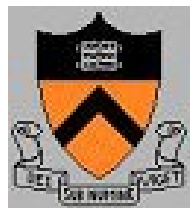
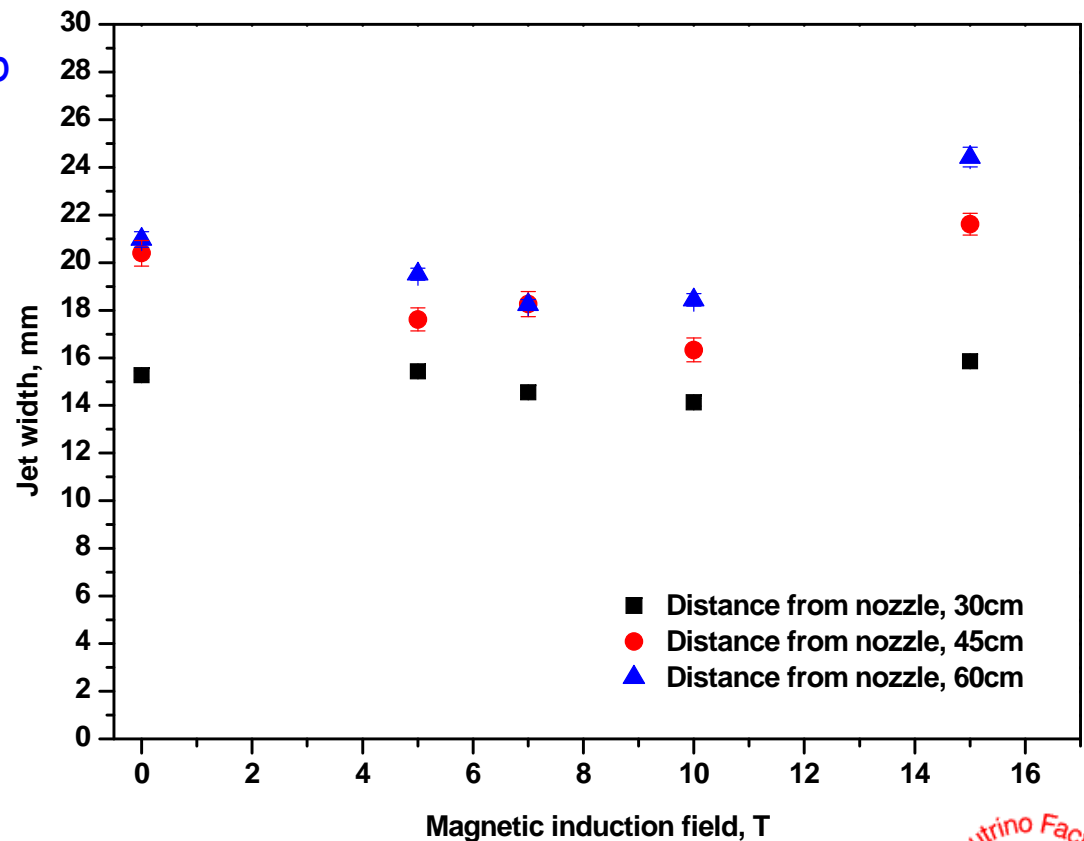
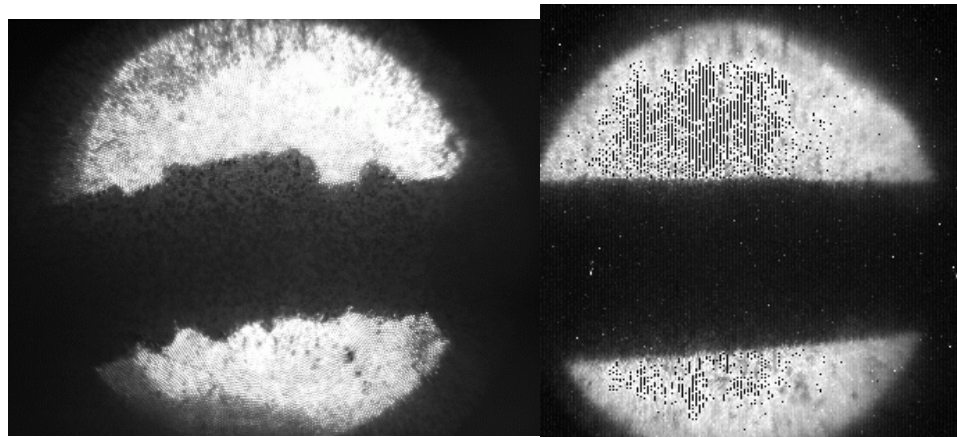

Could Reuse MERIT Equipment to Study Jet Issues without Beam

At a facility suitable for more general handling of mercury, could connect the mercury test volume to the mercury pump by hoses so that mercury enters at one end of magnet and exits at the other.

Could study jet quality in nozzles with no sharp bends.

Could use optical diagnostics with both side and top views.

Could add iron plugs to the MERIT magnet to study effect of field on a jet at 100 mrad (instead of 33 mrad as in MERIT @ CERN).

Could also study collection of the jet in a mercury pool.

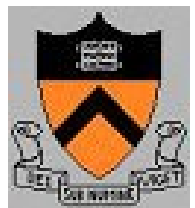
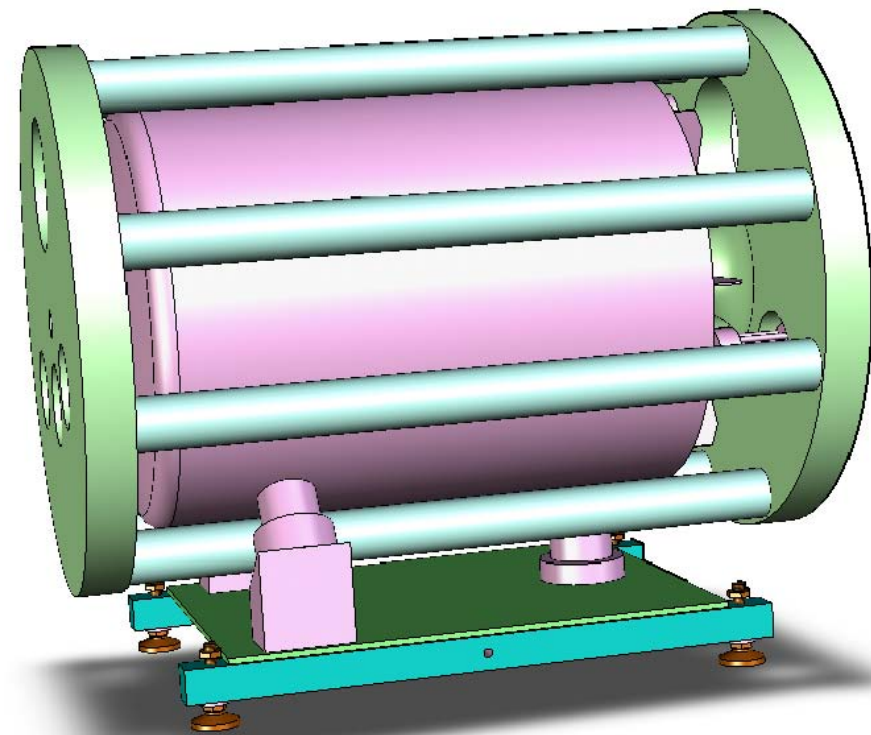
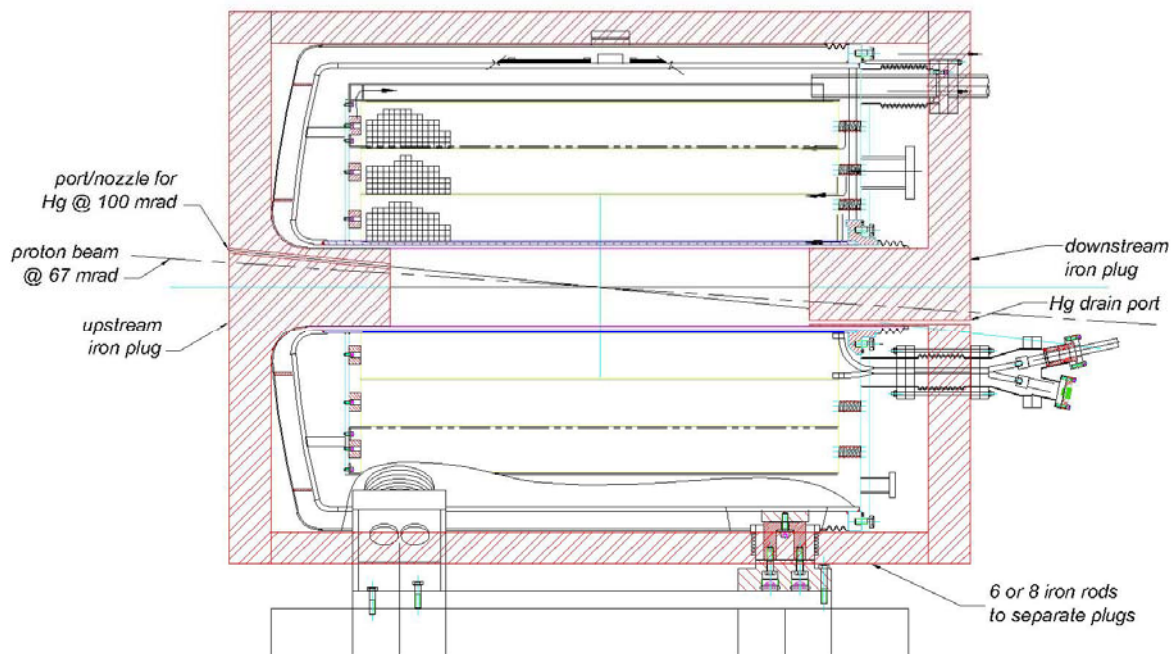

Option for Follow-On Studies at ORNL

A new fusion test facility in bldgs 7625, 7627 will be completed in late 2008.

Several 10-MW power supplies available.

LN₂ dewar 20-t overhead crane, equipment pit.

Could begin with zero field studies (nozzle optimization, Hg splash in pool,....)

Eventual option to use MERIT magnet at 15 (or 20!) T.

Bldg 7627

Bldg 7625

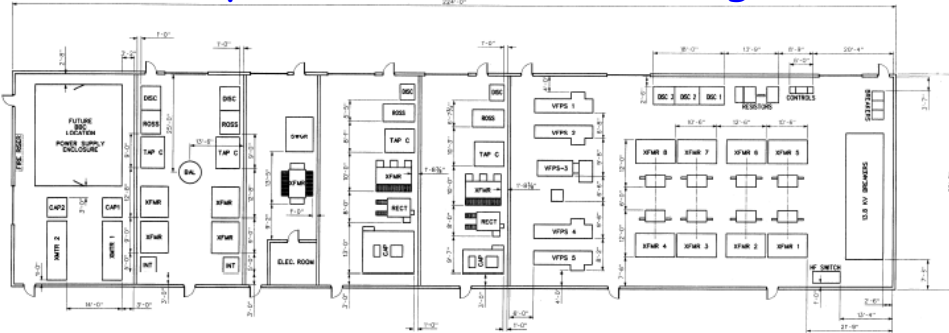

ELECTRICAL EQUIPMENT LAYOUT

Vertical field power supplies (capability of each)
650V peak

15,000 A pulsed > 5 sec

Voltage and/or current can be controlled by SCR gate waveform control

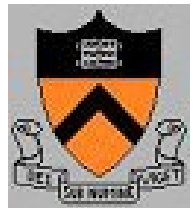

Lead-Bismuth Alloys

Lead-bismuth alloys are solid at room temperature, but liquefy at 70-125°C.

Easier to contain a target "spill" if material solidifies at room temperature.

More radioisotope production with Pb-Bi than with Hg (but "trivial" compared to a reactor).

Boiling of liquid target by proton beam (> 4 MW) less of an issue than with mercury.

Design studies for MERIT-like tests mandated by the NFMCC.

Some Pb-Bi alloys wet quartz, so difficult to use with optical diagnostics.

Woods metal (Low 158) does not wet glass (Palmer), but contains cadmium.

Pb-Bi-Sn alloys melt as low as 95°C.

Lab tests will be done soon on wetting of quartz by several low melting alloys.

Type/ Approx Temp	Antimony	Bismuth	Cadmium	Lead	Tin	1-9 lb	10-49 lb	50 + lb
Low 158	0 %	50%	10%	26.7%	13.3%	17.99	16.19	14.39
Low 158-190	0 %	42.5%	8.5%	37.7%	11.3%	17.99	16.19	14.39
Low 203	0%	52.5%	0%	32%	15.5%	17.99	16.19	14.39
Low 212	0%	39.4%	0%	29.8%	30.8%	17.99	16.19	14.39
Low 217-440	9%	48%	0%	28.5%	14.5%	17.99	16.19	14.39
Low 255	0%	55.5%	0%	44.5%	0%	17.99	16.19	14.39
Low 281	0%	58%	0%	0%	42%	17.99	16.19	14.39
Low 281-338	0%	40%	0%	0%	60%	17.99	16.19	14.39

