

The High-Power Target System for a Muon Collider or Neutrino Factory

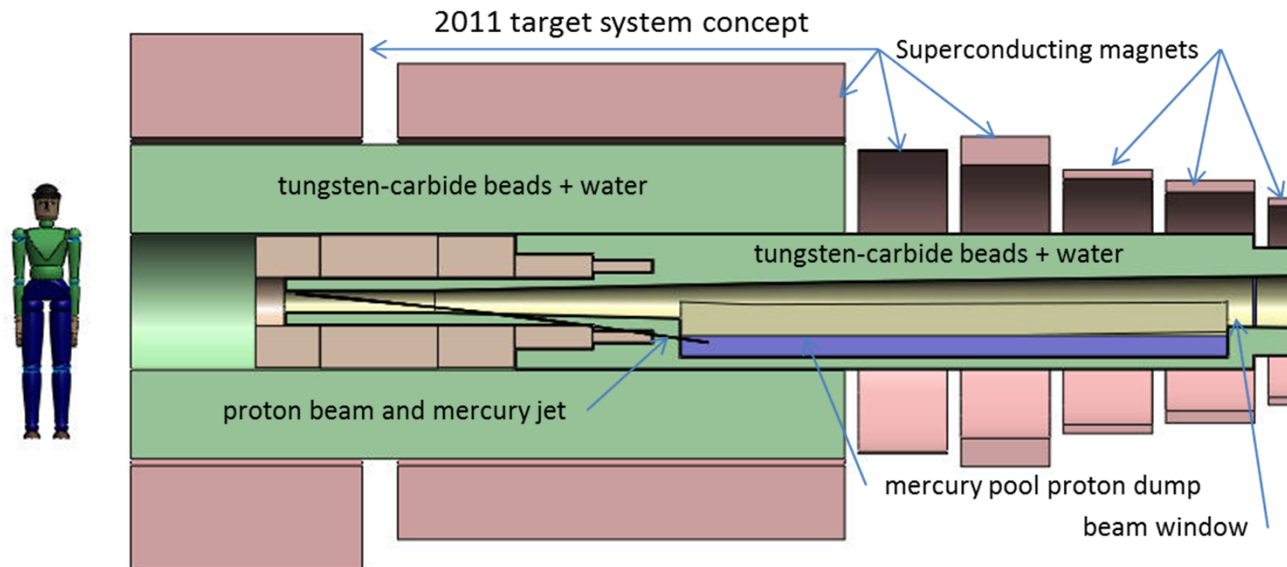

K. McDonald
Princeton U.
(Aug 4, 2011)
NuFact11
U. Genève



The Target is Pivotal between a Proton Driver and ν or μ Beams

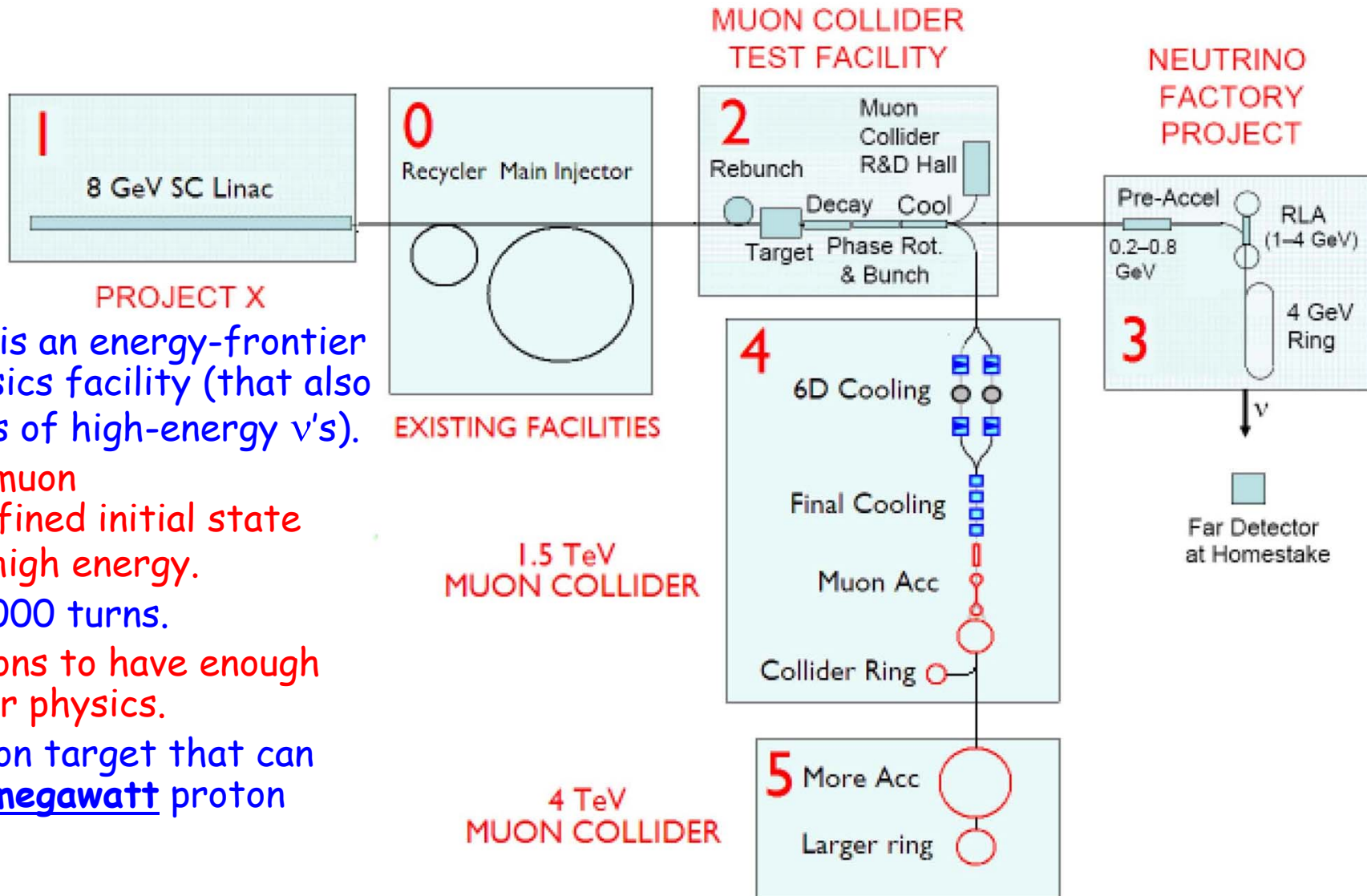

A Muon Collider is an energy-frontier particle-physics facility (that also produces lots of high-energy ν 's).

Higher mass of muon
 \Rightarrow Better defined initial state than e^+e^- at high energy.

A muon lives ≈ 1000 turns.

Need lots of muons to have enough luminosity for physics.

Need a production target that can survive multimewatt proton beams.



Targets for 2-4 MW Proton Beams

- 5-50 GeV beam energy appropriate for Superbeams, Neutrino Factories and Muon Colliders.
 $0.8-2.5 \times 10^{15}$ pps; $0.8-2.5 \times 10^{22}$ protons per year of 10^7 s.
 - Rep rate 15-50 Hz at Neutrino Factory/Muon Collider, as low as ≈ 2 Hz for Superbeam.
 - \Rightarrow Protons per pulse from 1.6×10^{13} to 1.25×10^{15} .
 - \Rightarrow Energy per pulse from 80 kJ to 2 MJ.
 - Small beam size preferred:
 - $\approx 0.1 \text{ cm}^2$ for Neutrino Factory/Muon Collider, $\approx 1 \text{ cm}^2$ for Superbeam.
 - Pulse width $\approx 1 \mu\text{s}$ OK for Superbeam, but $< 2 \text{ ns}$ desired for Neutrino Factory/Muon Collider.
- \Rightarrow Severe materials issues for target AND beam dump.
- Radiation Damage.
 - Melting.
 - Cracking (due to single-pulse "thermal shock").
- MW energy dissipation requires liquid coolant somewhere in system!

\Rightarrow No such thing as "solid-target-only" at this power level.



Target and Capture Topology: Solenoid

Desire $\approx 10^{14}$ μ/s from $\approx 10^{15}$ p/s (≈ 4 MW proton beam).

Highest rate μ^+ beam to date: PSI $\mu E4$ with $\approx 10^9$ μ/s from $\approx 10^{16}$ p/s at 600 MeV.

\Rightarrow Some R&D needed!

R. Palmer (BNL, 1994) proposed a solenoidal capture system.

Low-energy π 's collected from side long, thin cylindrical target.

Collects both signs of π 's and μ 's,

\Rightarrow Shorter data runs (with magnetic detector).

Solenoid coils can be some distance from proton beam.

\Rightarrow ≥ 4 -year life against radiation damage at 4 MW.

Liquid mercury jet target replaced every pulse.

Proton beam readily tilted with respect to magnetic axis.

\Rightarrow Beam dump (mercury pool) out of the way of secondary π 's and μ 's.



Present Target Concept

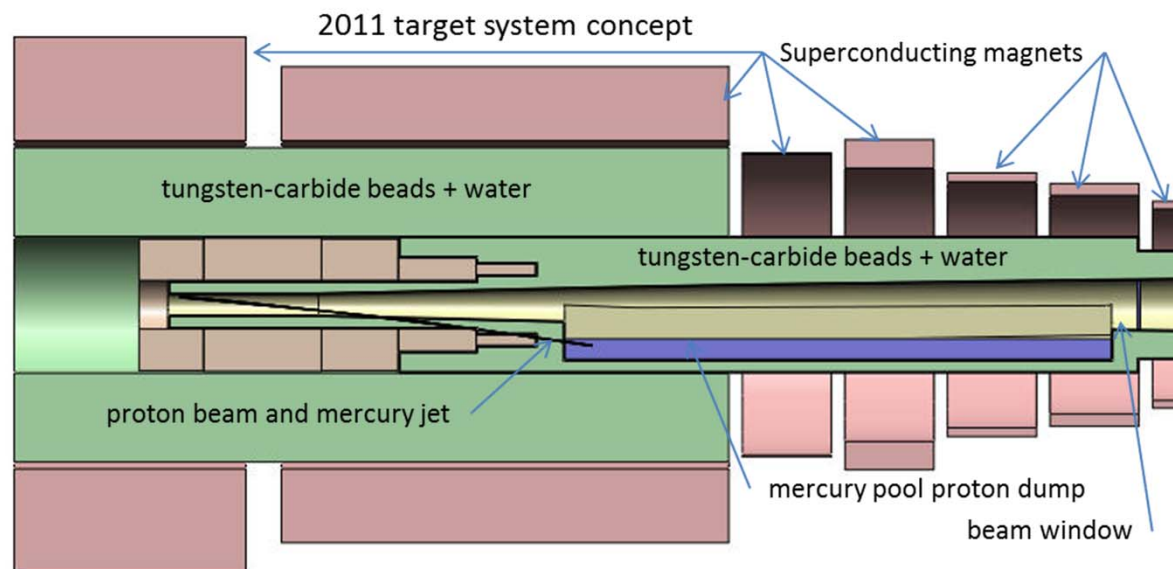

Shielding of the superconducting magnets from radiation is a major issue.

Magnet stored energy ~ 3 GJ!

Use of "magnetic bottles" around production targets proposed by Djilkibaev and Lobashev,

http://puhep1.princeton.edu/~mcdonald/examples/detectors/djilkibaev_aipcp_372_53_95.pdf



Why 20 T?

The baseline scenario has pions produced (almost) on axis of a 20-T solenoid, followed by an “adiabatic” field tapered down to 1.5 T = field strength of front-end π/μ beam transport.

We desire to capture all pions with $p_{\perp} \leq 200 \text{ MeV}/c$.

If used a 1.5-T solenoid around the target, would need aperture of radius 80 cm to capture these pions.

But, if use a 20-T solenoid these pions fit within an aperture of 7.5 cm.

The adiabatic taper down to 1.5 T has the adiabatic invariant $\Phi_0 = \pi R_0^2 B_0 = \pi c^2 p_{0\perp}^2 / e^2 B_0$, which implies that at the end of the taper the pions fit in an aperture of only 30 cm.

That is, the use of an initial strong solenoid provides a kind of “transverse cooling”.

In principle, this “cooling” would be even stronger if we could use a field higher than 20 T.



Free Liquid Jet Targets

Pros:

- No static solid window near target in the intense proton beam.
- Radiation damage to the liquid is not an issue.

Cons:

- Never used before as a production target.
- Leakage of radioactive liquid anywhere in the system is potentially more troublesome than breakup of a radioactive solid.

R&D: Proof of principle of a free liquid jet target has been established by the CERN MERIT Experiment. R&D would be useful to improve the jet quality, and to advance our understanding of systems design issues.

Personal view: This option deserves its status as the baseline for Neutrino Factories and Muon Colliders. *For Superbeams that will be limited to less than 2 MW, static solid targets continue to be appealing. At 4 MW beam power, would need to change a static solid target weekly, due to radiation damage.*



CERN MERIT Experiment (Nov 2007)

Proof-of-principle demonstration of a mercury jet target in a strong magnetic field, with proton bunches of intensity equivalent to a 4 MW beam.

Performed in the TT2A/TT2 tunnels at CERN.

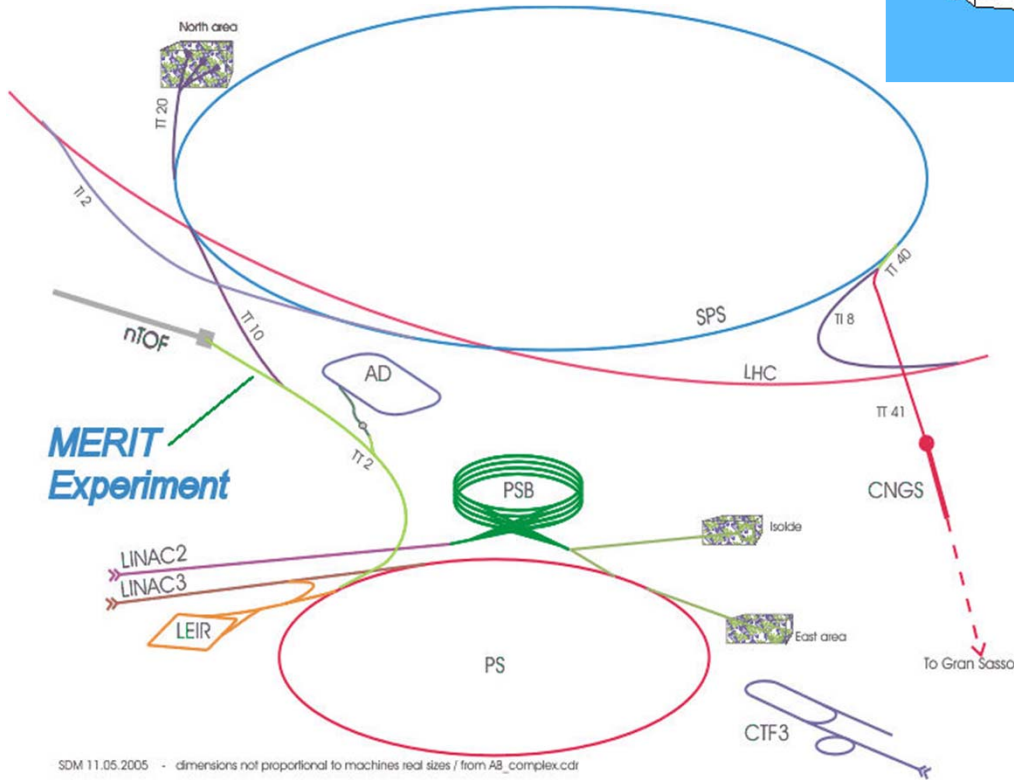
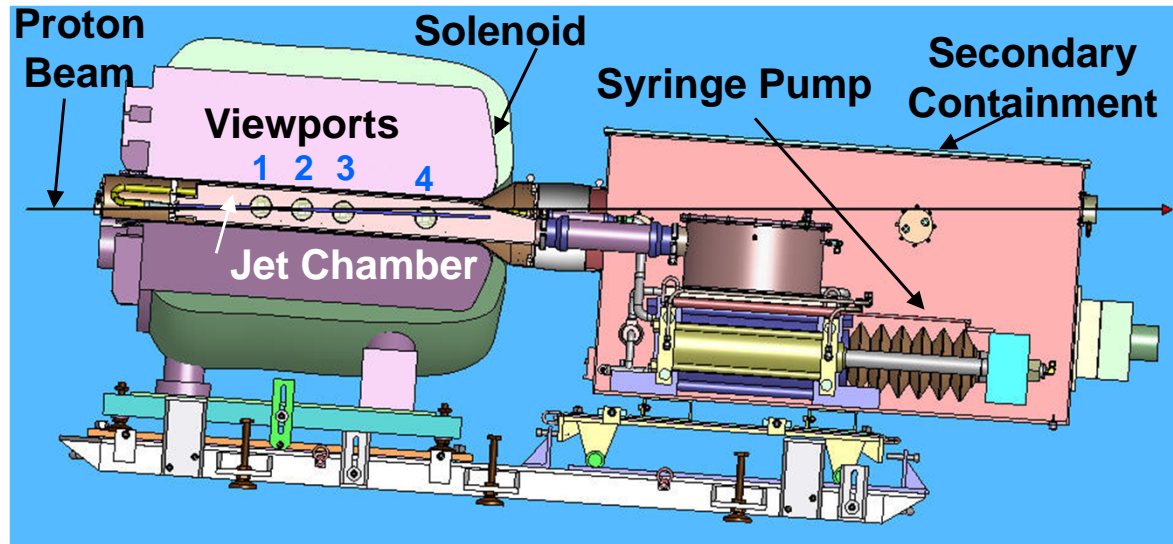

SDM 11.05.2005 - dimensions not proportional to machines real sizes / from AB_complex.cdr



MERIT Beam Pulse Summary

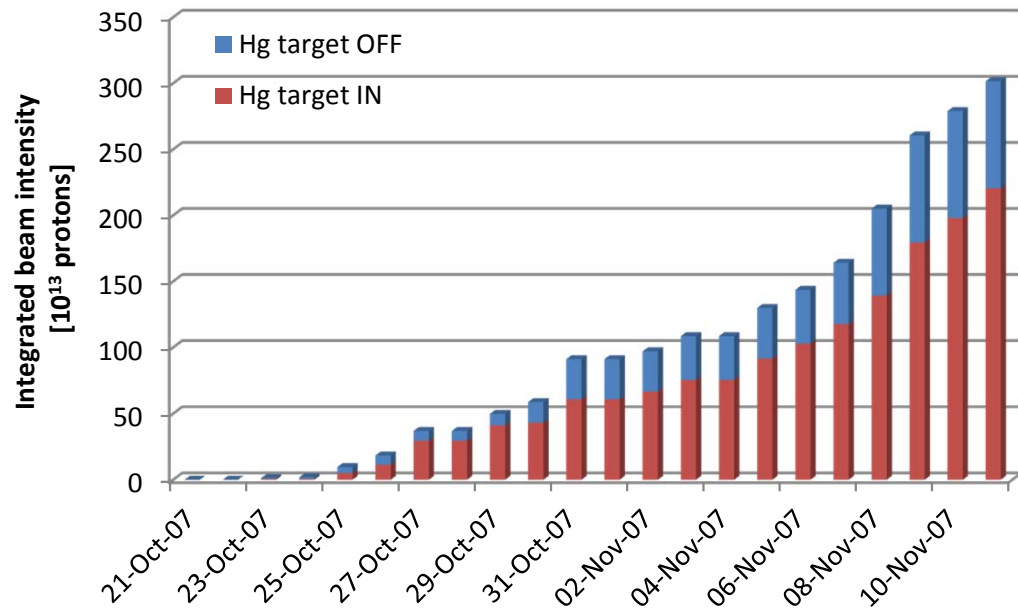

MERIT was not to exceed 3×10^{15} protons on Hg to limit activation.

30 Tp shot @ 24 GeV/c

- 115 kJ of beam power
- a PS machine record !

1 Tp = 10^{12} protons

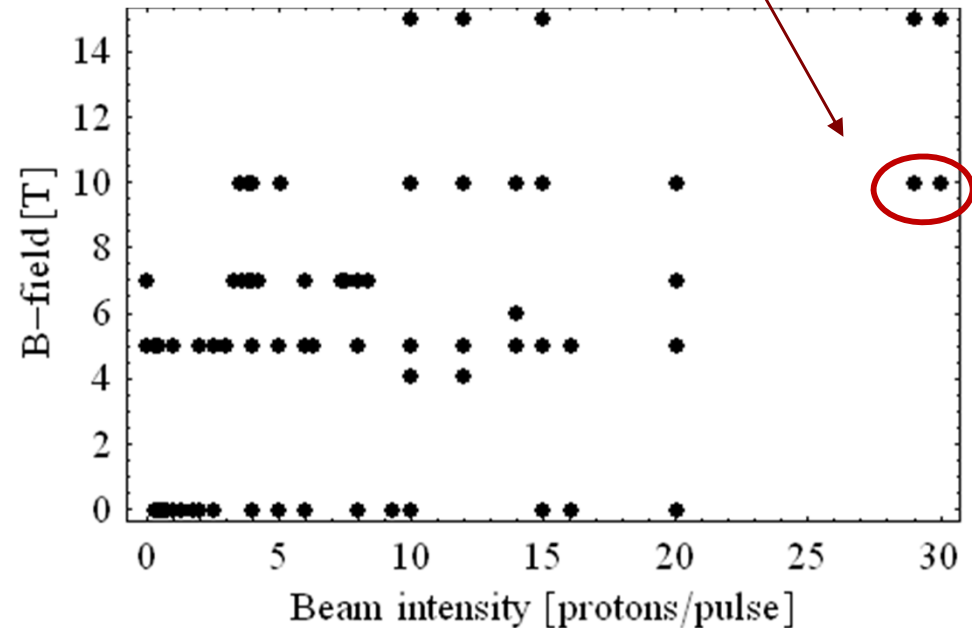

Disruption Length Analysis (H. Park, PhD Thesis)

Observe jet at viewport 3 at 500 frames/sec,
measure total length of disruption
of the mercury jet by the proton beam.

Images for 10 T_p, 24 GeV, 10 T:

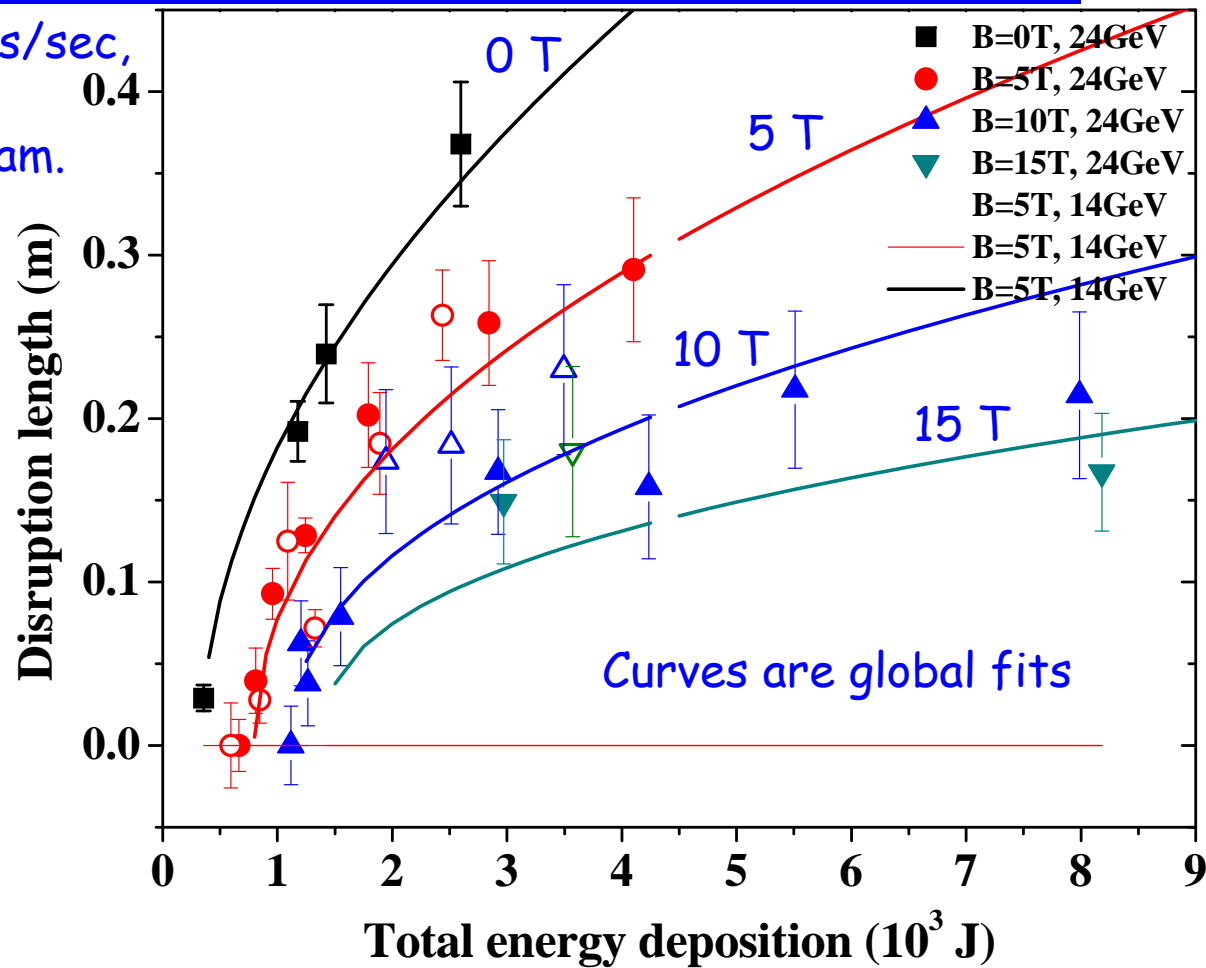
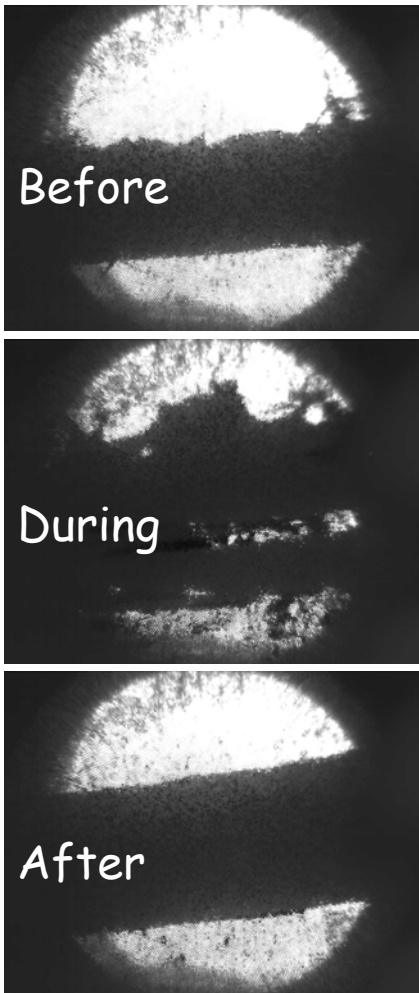

Disruption length never longer than region of overlap of jet with proton beam.

No disruption for pulses of $< 2 T_p$ in 0 T ($< 4 T_p$ in 10 T).

Disruption length shorter at higher magnetic field.



Filament Velocity Analysis (H. Park)

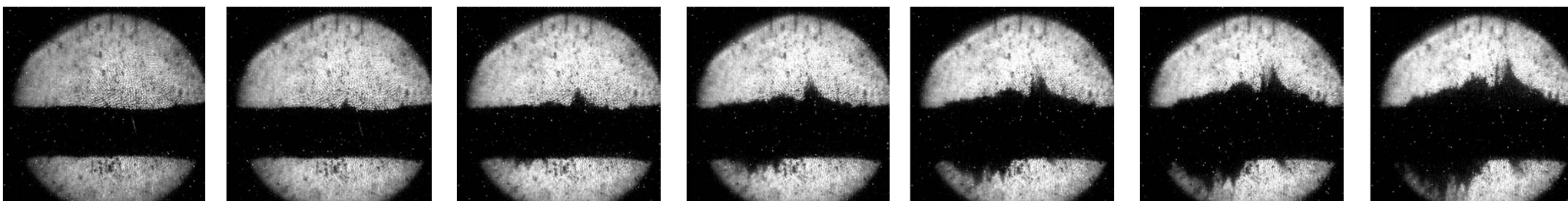

Measure position of tip of filament in each frame, and fit for t_v and v .

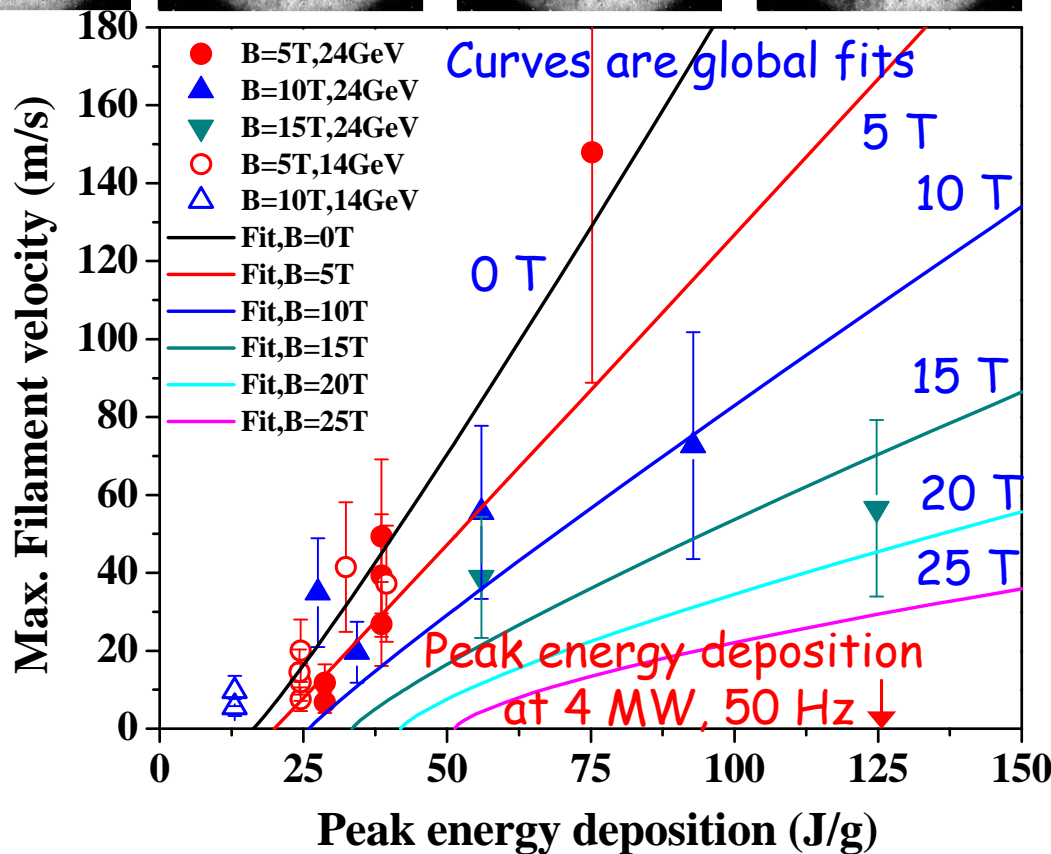
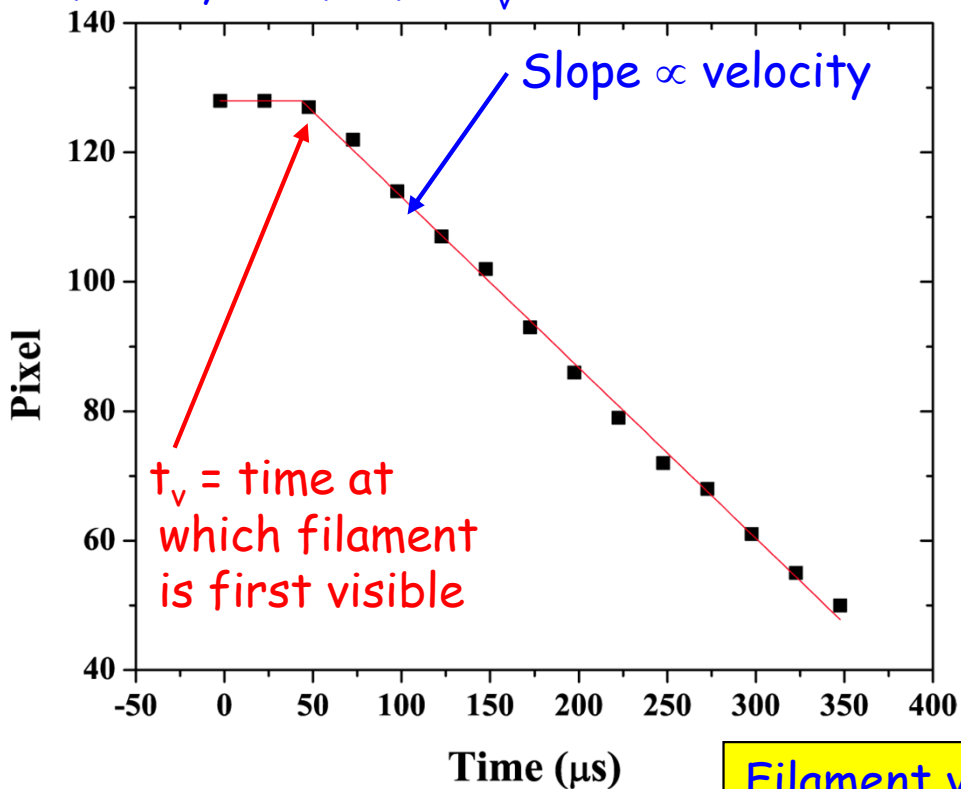

Filament velocity suppressed by high magnetic field.
 Filament start time \gg transit time of sound across the jet.



Pump-Probe Studies

? Is pion production reduced during later bunches due to disruption of the mercury jet by the earlier bunches?

At 14 GeV, the CERN PS could extract several bunches during one turn (pump), and then the remaining bunches at a later time (probe).

Pion production was monitored for both target-in and target-out events by a set of diamond diode detectors.

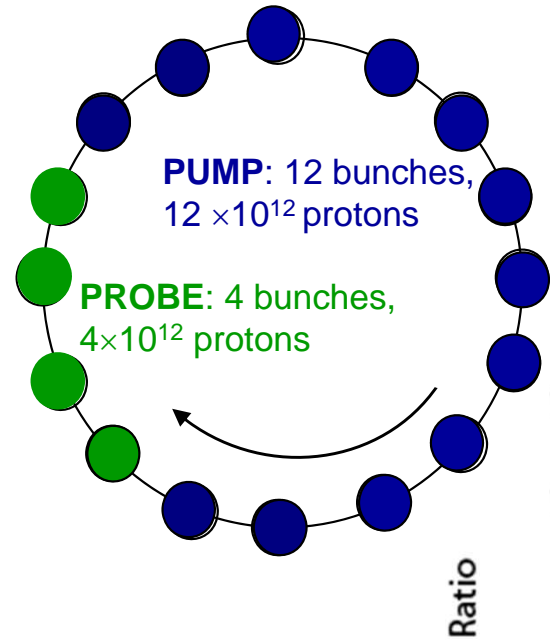

$$\text{Ratio} = \frac{\frac{\text{Probe}_{\text{target in}} - \text{Probe}_{\text{target out}}}{\text{Pump}_{\text{target in}} - \text{Pump}_{\text{target out}}}}{\frac{\text{Probe}_{\text{target out}}}{\text{Pump}_{\text{target out}}}}$$

Ratio Target In-Out/Target Out

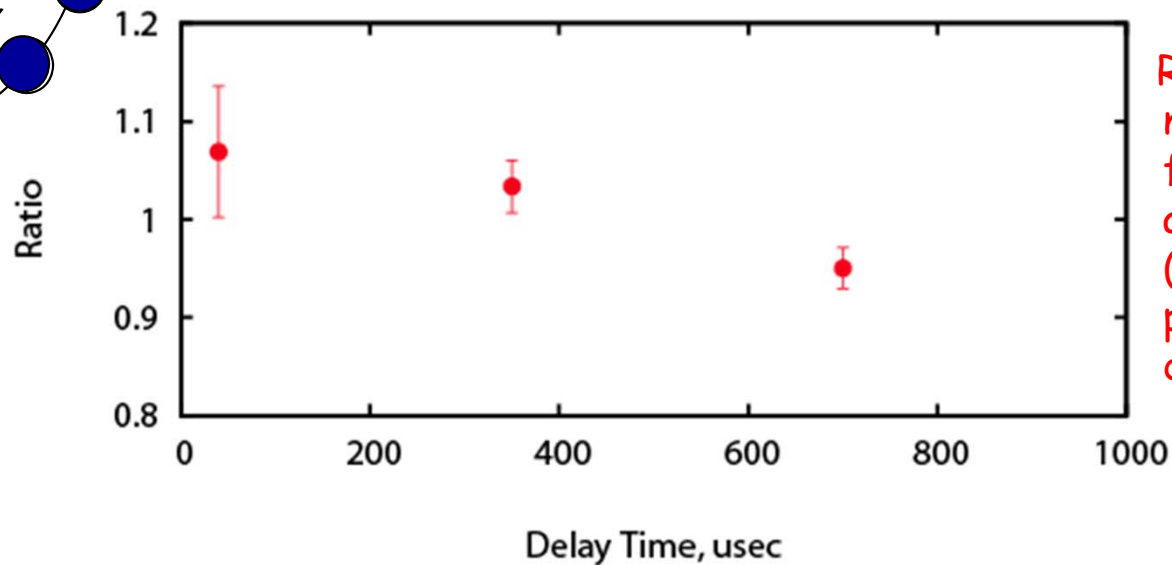

Results consistent with no loss of pion production for bunch delays of 40 and 350 μs , and a 5% loss (2.5- σ effect) of pion production for bunches delayed by 700 μs .



Damage by Mercury Droplets?

Cavitation pitting of (untreated) SS wall surrounding Hg target after 100 pulses (SNS):

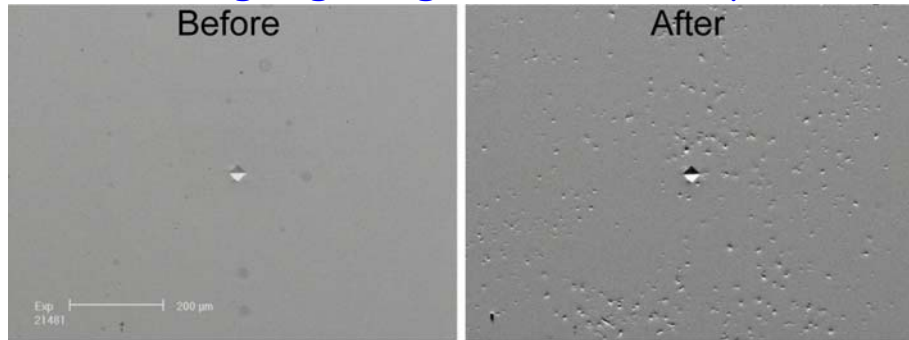

TL - High Power Target
Specimen # 29754
Equivalent SNS Power Level = 2.5

Numerical model by T. Davenne (RAL) suggests that droplets can cause damage.

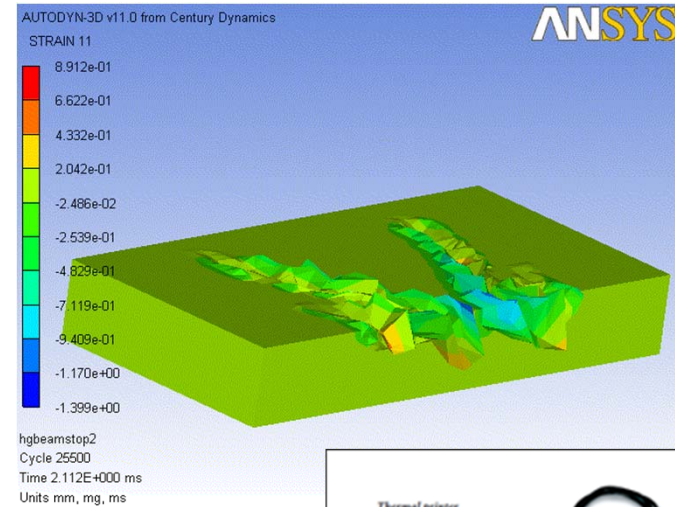

Avoid this issue with free jet. But, is damage caused by mercury droplets from jet dispersion by the beam?

Preliminary survey of MERIT primary containment vessel shows no damage.

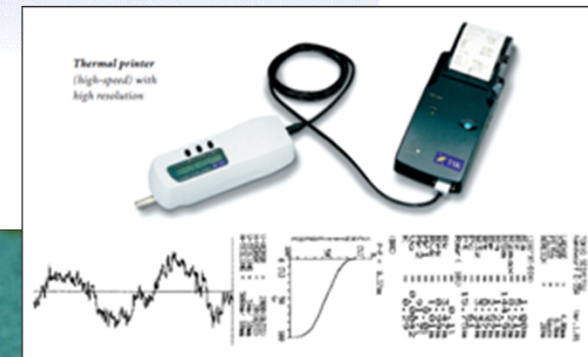

Further studies to be made with Zeiss surface profiler.



MERIT Experiment Summary

The MERIT experiment established proof-of-principle of a free mercury jet target in a strong magnetic field, with proton bunches of intensity equivalent to a 4 MW beam.

- The magnetic field stabilizes the liquid metal jet and reduces disruption by the beam.
- The length of disruption is less than the length of the beam-target interaction, \Rightarrow Feasible to have a new target every beam pulse with a modest velocity jet.
- Velocity of droplets ejected by the beam is low enough to avoid materials damage.
- The threshold for disruption is a few $\times 10^{12}$ protons, permitting disruption-free operation at high power if can use a high-rep-rate beam.
- Even with disruption, the target remains fully useful for secondary particle production for $\approx 300 \mu\text{s}$, permitting use of short bunch trains at high power.
- No apparent damage to stainless-steel wall only 1 cm from interaction region.



Integrated Design Study of the Target System

Prior efforts on the target system for a Muon Collider/Neutrino Factory have emphasized proof-of-principle demonstration of a free mercury jet target inside a solenoid magnet.

Future effort should emphasize integration of target, beam dump and **internal shield** into the capture magnet system.

The target system has complex subsystems whose design requires a large variety of technical expertise.

- Nozzle configuration (fluid engineering at high Reynolds number)
- Solid-target alternatives (mechanical and thermal engineering)
- Mercury collection pool/beam dump (fluid, mechanical and thermal engineering)
- Internal shield of the superconducting magnets (fluid, mechanical and thermal engineering)
- Magnet design (SC-1: Nb₃Sn outsert, copper insert with option for high-T_c insert; cryogenic, fluid, mechanical engineering)
- Mercury flow loop (fluid engineering)
- Remote handling for maintenance (mechanical engineering)
- Target hall and infrastructure (mechanical engineering)



Mercury Pool Issues

Both the jet and the proton beam will disrupt the mercury pool (simulations by N. Simos).

⇒ Need splash mitigation (V. Graves, N. Simos, P. Spampinato)

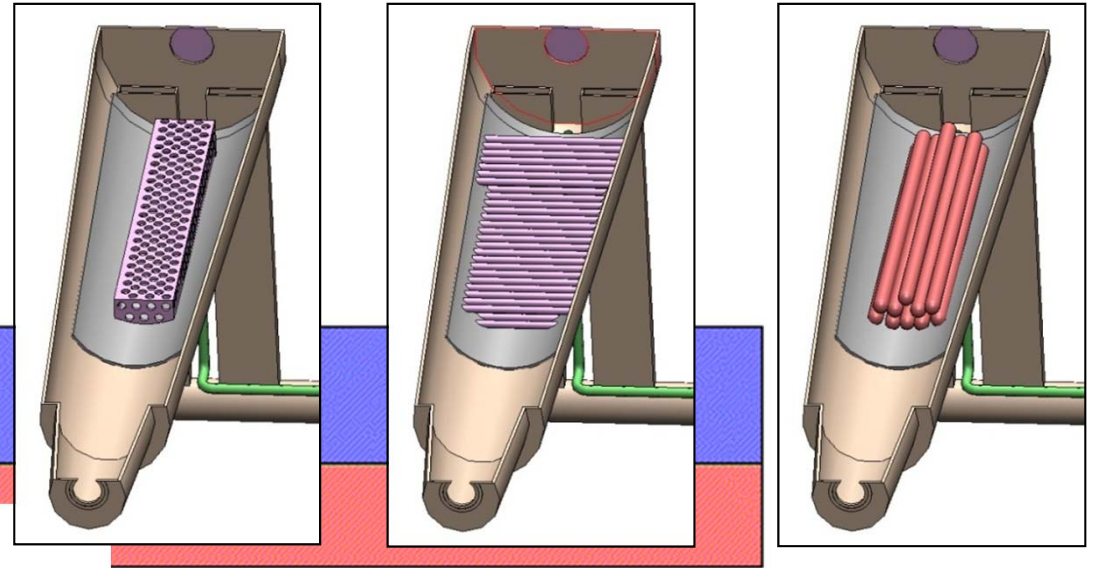
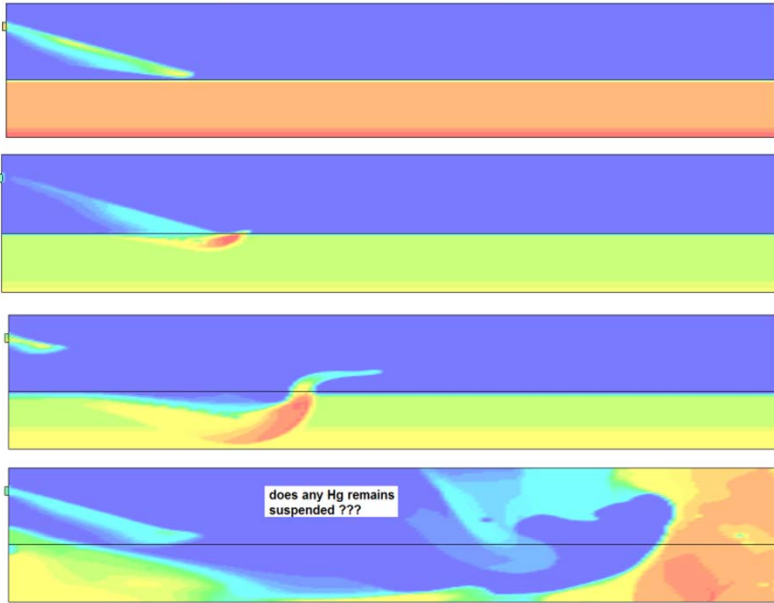

Mercury drain underneath the 6-T copper magnet:

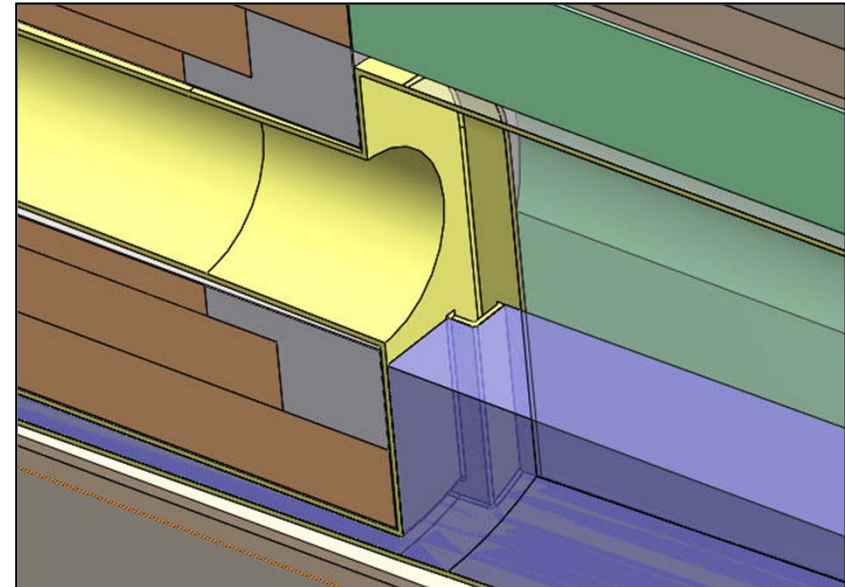
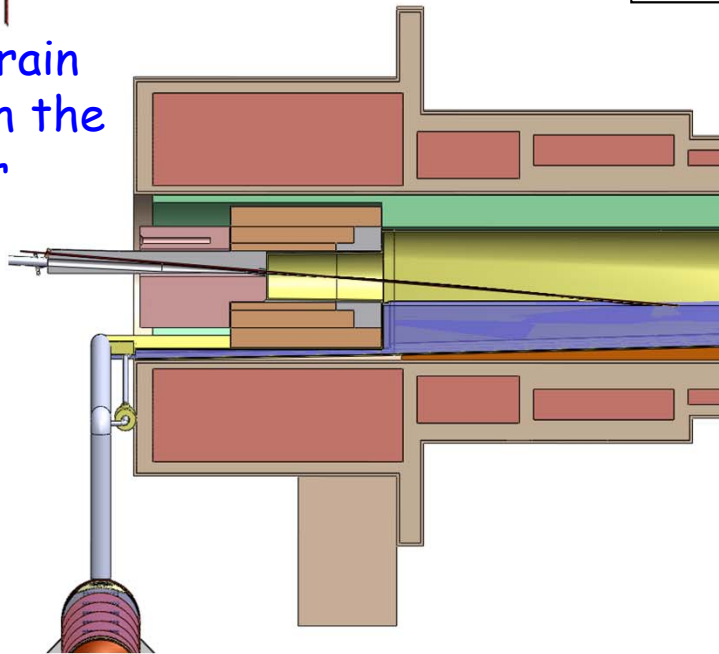

High Levels of Energy Deposition in the Target System

Deposited Power (MGray/year)

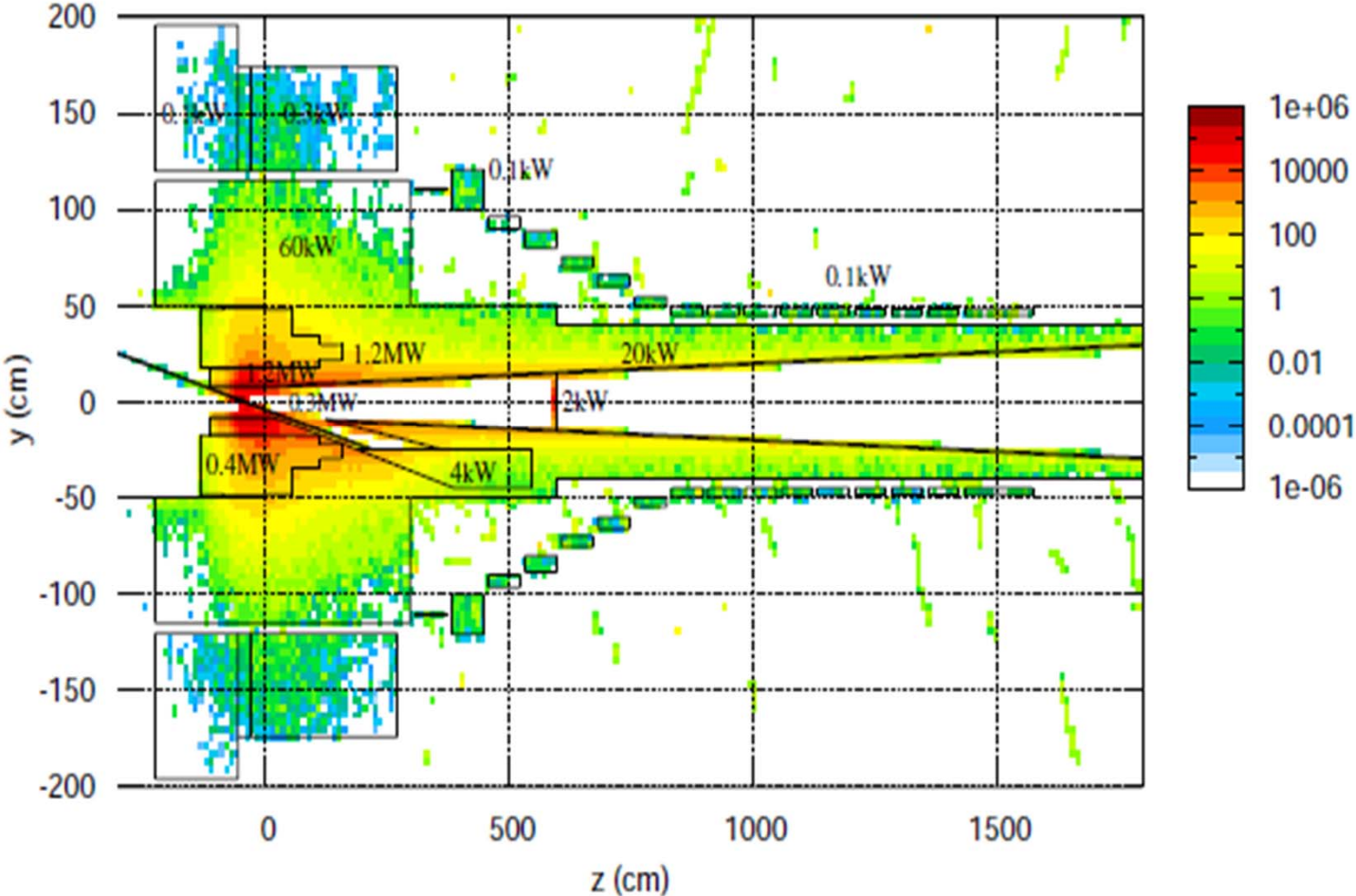

FLUKA simulations agree well with MARS15 simulations (N. Souchlas).

Power deposition in the superconducting magnets and the tungsten-carbide + water shield inside them, according to a FLUKA simulation (J. Back).

Approximately 2.4 MW must be dissipated in the shield.

Some 800 kW flows out of the target system into the downstream beam-transport elements!

Total energy deposition in the target magnet string is ~ 1 kW @ 4k.

Peak energy deposition is about 0.03 mW/g.



Massive Shield of Tungsten-Carbide Beads inside Superconducting Magnets

Random packing of spheres
⇒ ≅ 63% WC by volume.

Support the ≈ 100 tons of shielding off the magnets, or at the end?

2 mm max. deformation, if supported at ends (R. Weggel).

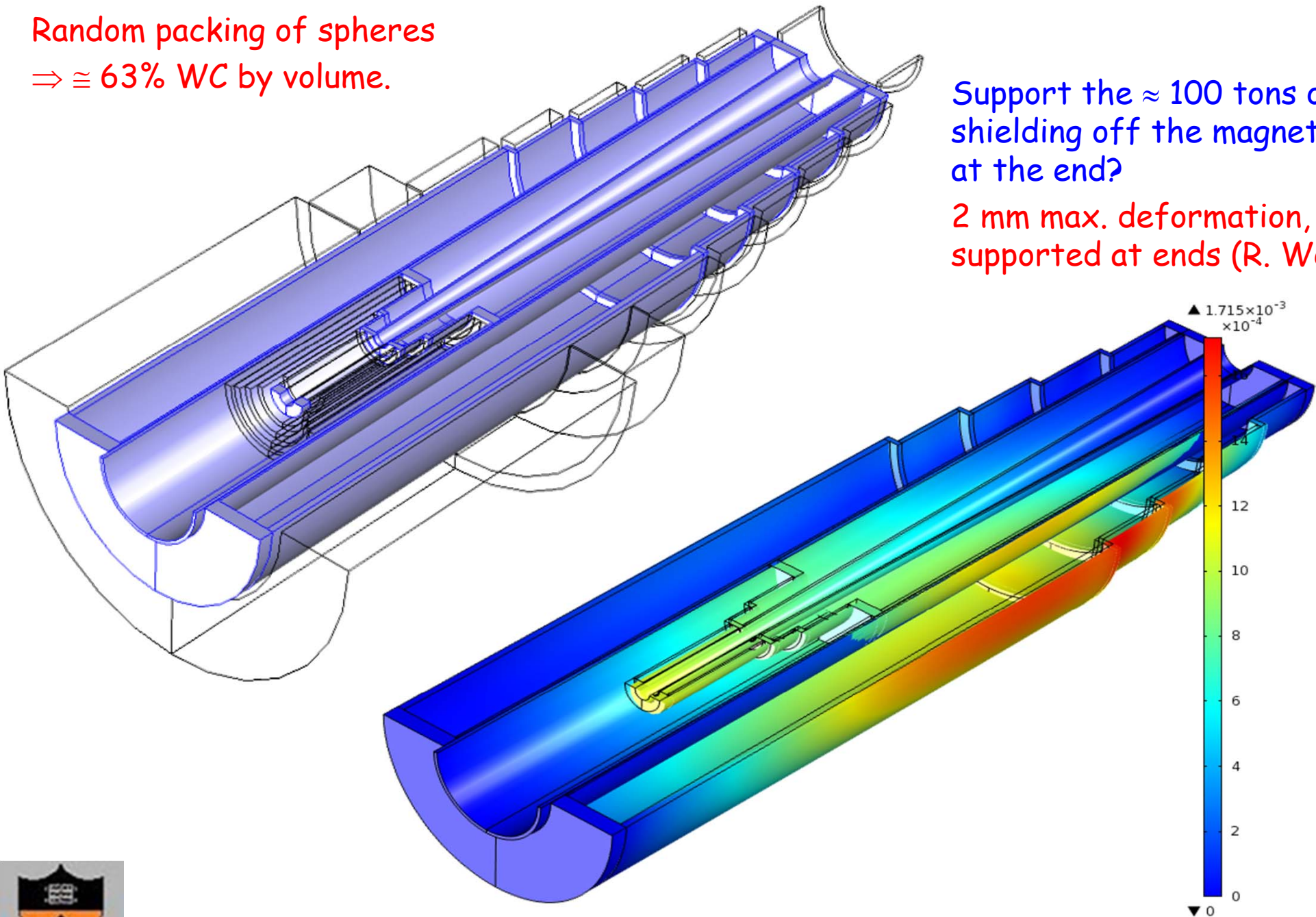

Overview of Radiation Issues for the Solenoid Magnets

The magnets at a Muon Collider and Neutrino Factory will be subject to high levels of radiation damage, and high thermal loads due to secondary particles, unless appropriately shielded.

To design appropriate shielding it is helpful to have quantitative criteria as to maximum sustainable fluxes of secondary particles in magnet conductors, and as to the associated thermal load.

We survey such criteria first for superconducting magnets, and then for room-temperature copper magnets.

A recent review is by H. Weber, *Int. J. Mod. Phys. 20* (2011),

http://puhep1.princeton.edu/~mcdonald/examples/magnets/weber_ijmpe_20_11.pdf

http://www.hep.princeton.edu/~mcdonald/mumu/target/Weber/weber_050511.pdf

Most radiation damage data is from exposures to "reactor" neutrons.

Models of radiation damage to materials associate this with "displacement" of the electronic (not nuclear) structure of atoms, with a defect being induced by ≈ 25 eV of deposited energy.

Classic reference: G.H. Kinchin and R.S. Pease, *Rep. Prog. Phys. 18*, 1 (1955),

http://puhep1.princeton.edu/~mcdonald/examples/magnets/kinchin_rpp_18_1_55.pdf

Hence, it appears to me most straightforward to relate damage limits to (peak) energy deposition in materials. [Use of DPA = displacements per atom seems ambiguous due to lack of a clear definition of this unit.]



Radiation Damage to Superconductor

The ITER project quotes the lifetime radiation dose to the superconducting magnets as 10^{22} n/m² for reactor neutrons with $E > 0.1$ MeV. This is also 10^7 Gray = 10^4 J/g accumulated energy deposition. For a lifetime of 10 "years" of 10^7 s each, the peak rate of energy deposition would be 10^4 J/g / 10^8 s = 10^{-4} W/g = 0.1 mW/g.

The ITER Design Requirements document, http://puhep1.princeton.edu/~mcdonald/examples/magnets/iter_fdr_DRG1.pdf reports this as 1 mW/cm³ of peak energy deposition (which seems to imply $\rho_{\text{magnet}} \approx 10$ g/cm³).

Table 1.17-1 Maximum Nuclear Load Limits to the Magnet

Parameters	Unit	H	DT	TBA
Local nuclear heat in the conductor	kW/m ³	0	1	
Local nuclear heat in the case and structures	kW/m ³	0	2	
Peak radiation dose to coil insulator	Gray	0	10×10^6	
Total neutron flux to coil insulator	N/m ²	0	10^{22}	
Total nuclear heat in the magnets	kW	See Table 1.15-5		

Damage to Nb-based superconductors appears to become significant at doses of $2-3 \times 10^{22}$ n/m² :

A. Nishimura *et al.*, Fusion Eng. & Design **84**, 1425 (2009)

http://puhep1.princeton.edu/~mcdonald/examples/magnets/nishimura_fed_84_1425_09

Reviews of these considerations for ITER:

J.H. Schultz, IEEE Symp. Fusion Eng. 423 (2003)

http://puhep1.princeton.edu/~mcdonald/examples/magnets/schultz_ieeesfe_423_03.pdf

http://puhep1.princeton.edu/~mcdonald/examples/magnets/schultz_cern_032205.pdf

Reduction of critical current of various Nb-based Conductors as a function of reactor neutron fluence. From Nishimura *et al.*

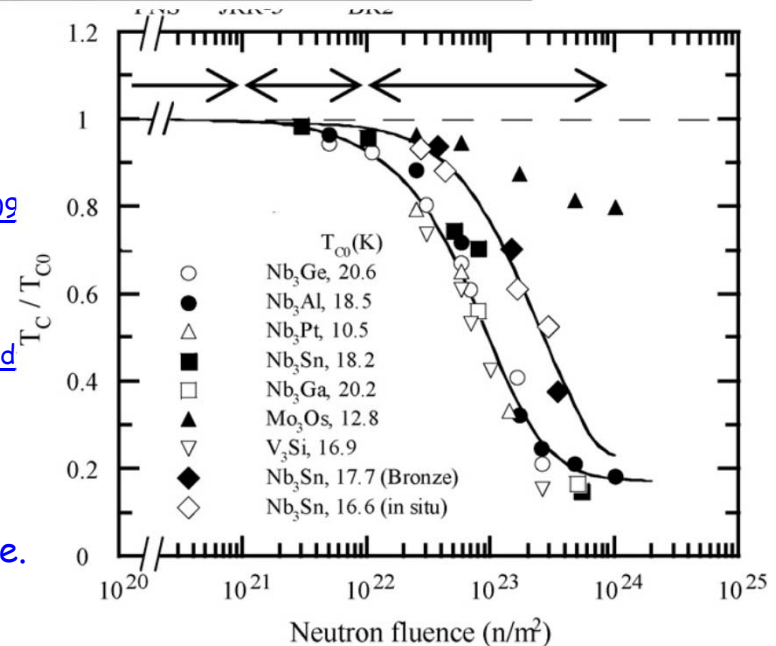

Radiation Damage to Organic Insulators

R&D on reactor neutron damage to organic insulators for conductors is carried out at the Atominstitut, U Vienna, <http://www.ati.ac.at/> Recent review:

R. Prokopec *et al.*, Fusion Eng. & Design **85**, 227 (2010)

http://puhep1.princeton.edu/~mcdonald/examples/magnets/prokopec_fed_85_227_10.pdf

The usual claim seems to be that "ordinary" epoxy-based insulators have a useful lifetime of 10^{22} n/m² for reactor neutrons with $E > 0.1$ MeV. This is, I believe, the underlying criterion for the ITER limit that we have recently adopted in the Target System Baseline,

http://puhep1.princeton.edu/~mcdonald/mumu/target/target_baseline_v3.pdf

Efforts towards a more rad hard epoxy insulation seem focused on cyanate ester (CE) resins, which are somewhat expensive (and toxic). My impression is that use of this insulation brings about a factor of 2 improvement in useful lifetime, but see the cautionary summary of the 2nd link above.

Failure mode is loss of shear strength.
Plot show ratio of shear strength (ILSS) To nominal for several CE resin variants at reactor neutron fluences of $1-5 \times 10^{22}$ n/m².
From Prokopec *et al.*

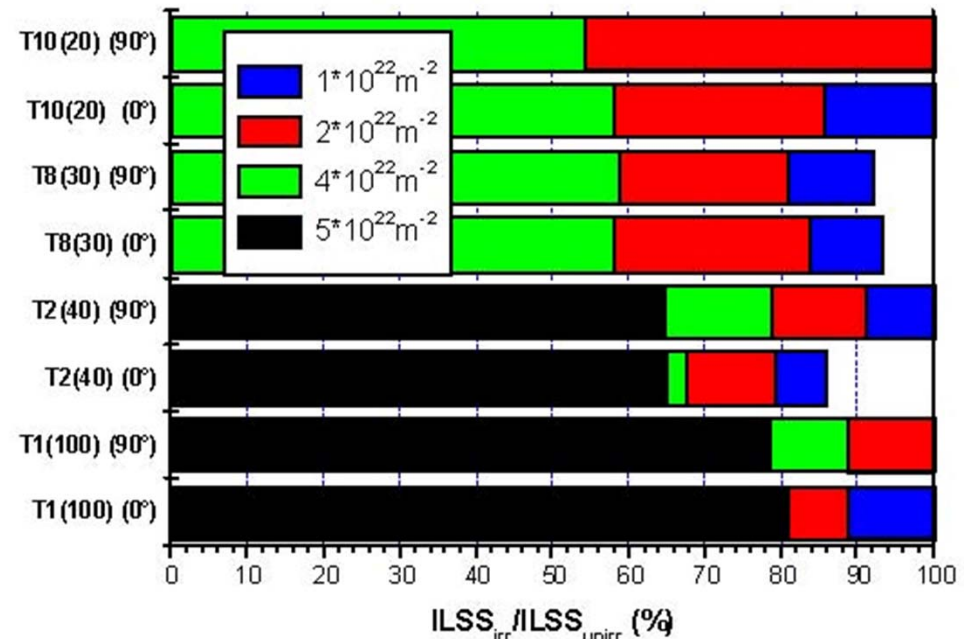

Radiation Damage to the Stabilizer

Superconductors for use in high thermal load environments are fabricated as cable in conduit, with a significant amount of copper or aluminum stabilizer (to carry the current temporarily after a quench).

The resistivity of Al is about 4 times that of Cu at 4K, \Rightarrow favorable to use copper.

Radiation damage equivalent to 10^{21} n/m^2 doubles the resistivity of Al and increases that of Cu by 10%.

http://puhep1.princeton.edu/~mcdonald/examples/magnets/klabunde_jnm_85-86_385_79.pdf

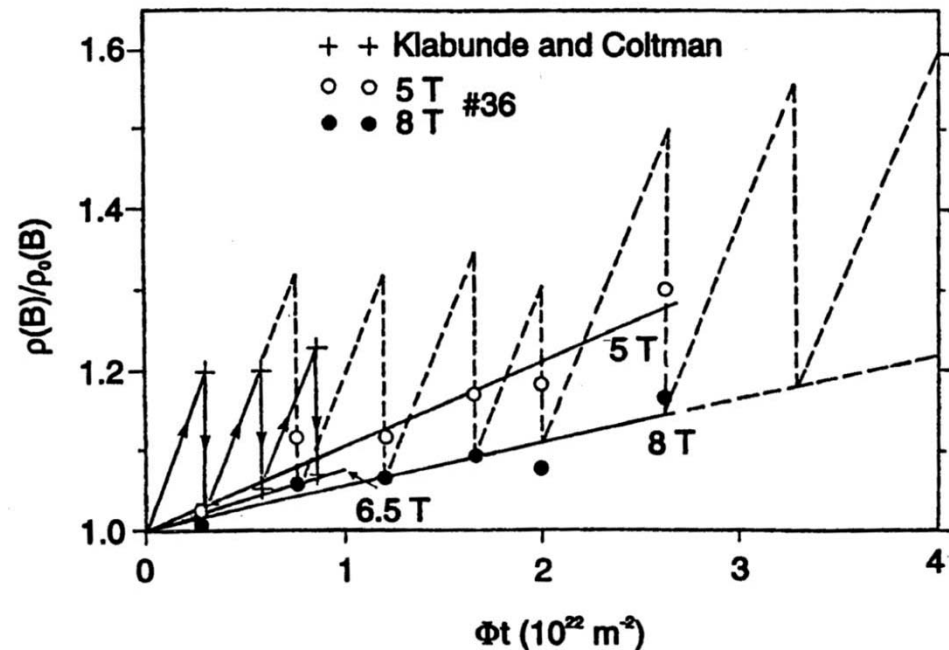
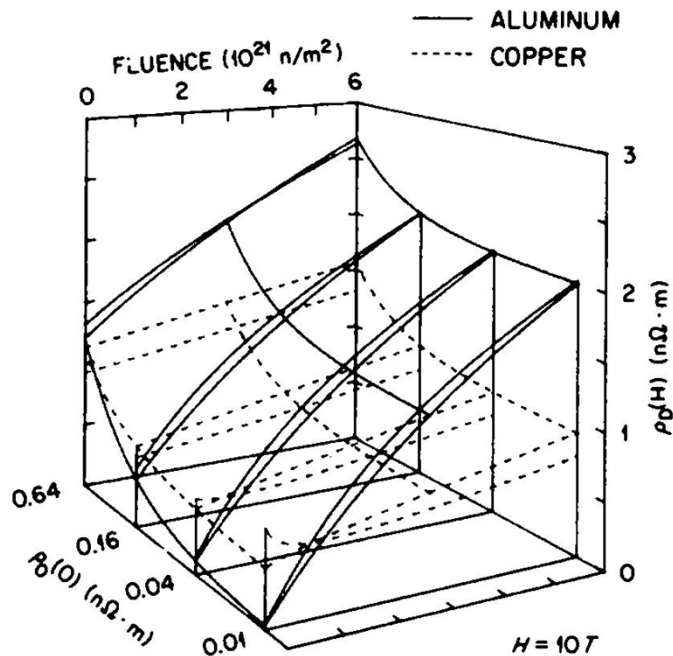

Annealing by cycling to room temperature gives essentially complete recovery of the low-temperature resistivity of Al, but only about 80% recovery for copper.

Cycling copper-stabilized magnets to room temperature once a year would result in about 20% increase in the resistivity of copper stabilizer in the "hot spot" over 10 years; Al-stabilized magnets would have to be cycled to room temperature several times a year (and have much higher resistivity).

http://puhep1.princeton.edu/~mcdonald/examples/magnets/guinan_jnm_133_357_85.pdf

Hence, Cu stabilizer is to be preferred.



Radiation Damage to Inorganic Insulators

MgO and $MgAl_2O_4$ "mineral insulation" is often regarded as the best inorganic insulator for magnets. It seems to be considered that this material remains viable mechanically up to doses of 10^{26} n/m^2 for reactor neutrons with $E > 0.1$ MeV., i.e., about 10,000 times that of the best organic insulators.

F.W. Clinard Jr *et al.*, J. Nucl. Mat. **108-109**, 655 (1982),

http://puhep1.princeton.edu/~mcdonald/examples/magnets/clinard_jnm_108-109_655_82.pdf

Question: Is the copper or SS jacket of a cable-in-conduit conductor with MgO insulation also viable at this dose?

The main damage effect seems to be swelling of the MgO, which is not necessarily a problem for the powder insulation used in magnet conductors.

PPPL archive of C. Neumeyer: http://www.pppl.gov/~neumeyer/ITER_IVC/References/

KEK may consider MgO-insulated magnets good only to 10^{11} Gray $\sim 10^{26}$ n/m^2 .

http://www-ps.kek.jp/kekpsbcg/conf/nbi/02/radresmag_kusano.pdf

Zeller advocates use of MgO-insulated superconductors, but it is not clear to me that this would permit significantly higher doses due to limitations of the conductor itself.



Radiation Damage to Copper at Room Temperature

Embrittlement of copper due to radiation becomes significant at reactor neutrino doses $> 10^{23} \text{ n/m}^2$.

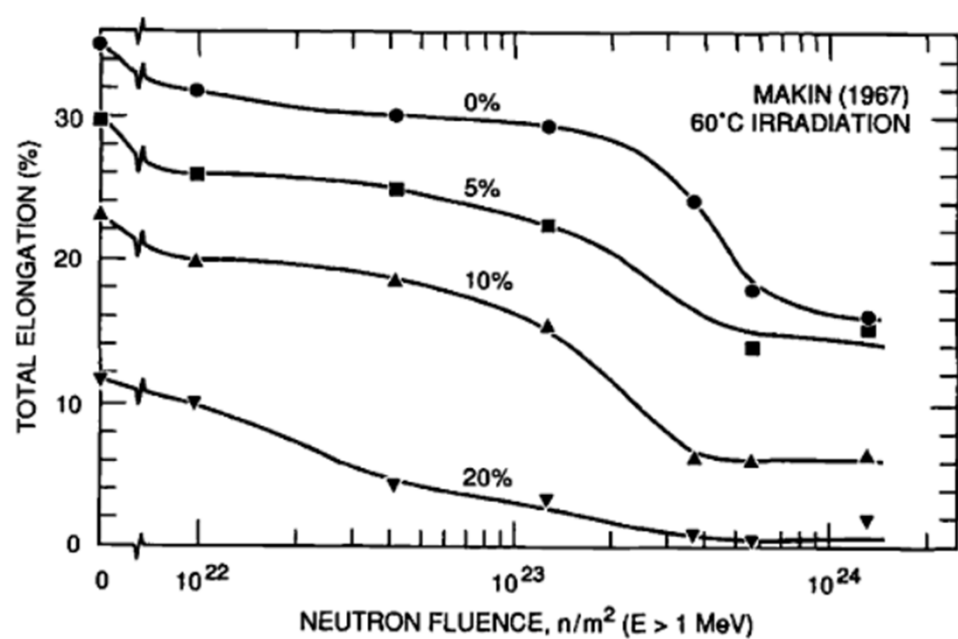

Not clear if this is a problem for resistive copper magnets.

N. Mokhov quotes limit of $10^{10} \text{ Gy} = 100 \text{ mW/g}$ for 10 "years" of 10^7 s each.

<http://www-ap.fnal.gov/users/mokhov/papers/2006/Conf-06-244.pdf>

Summary

While proof of principle of a free mercury jet target for a 4-MW proton beam was established by the CERN MERIT experiment, significant design issues must be addressed in the coming years by an integrated study involving diverse engineering considerations.

