

# The High-Power-Target System of a Muon Collider or Neutrino Factory

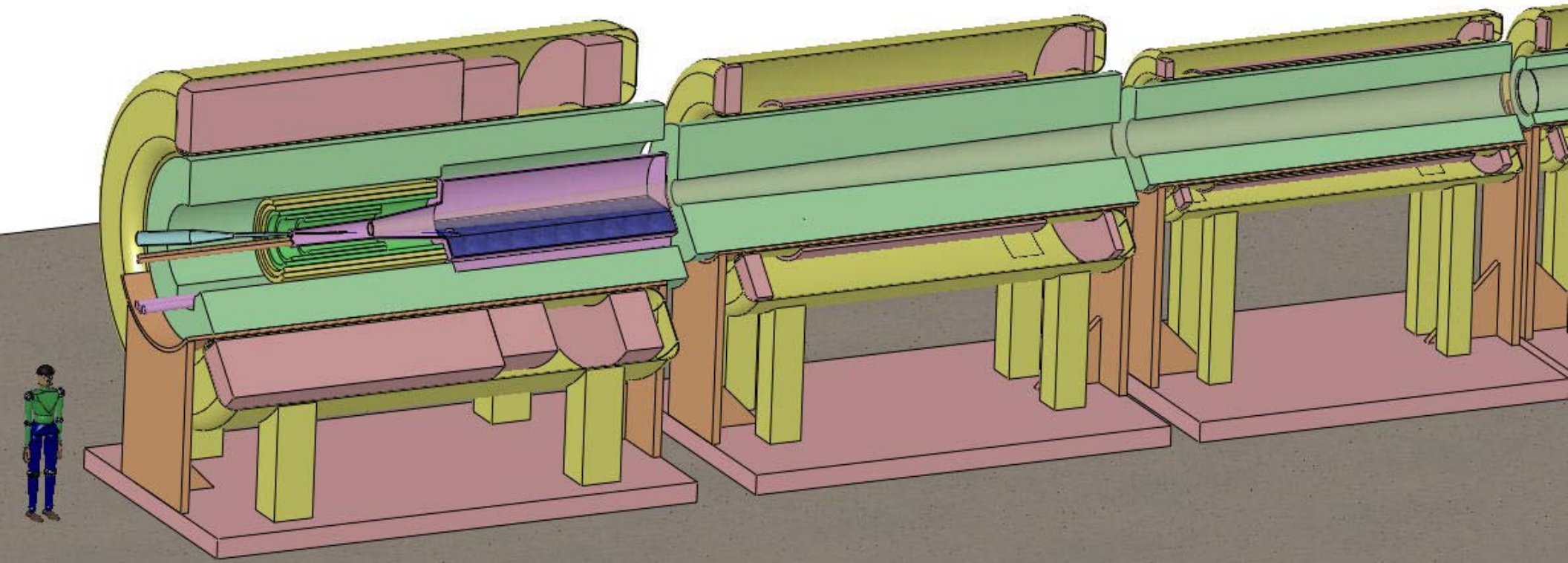

K. McDonald

*Princeton U.*

(April 19, 2012)

8<sup>th</sup> IDS-NF Plenary Meeting

*University of Glasgow*



# The Target System of a Muon-Collider or Neutrino Factory

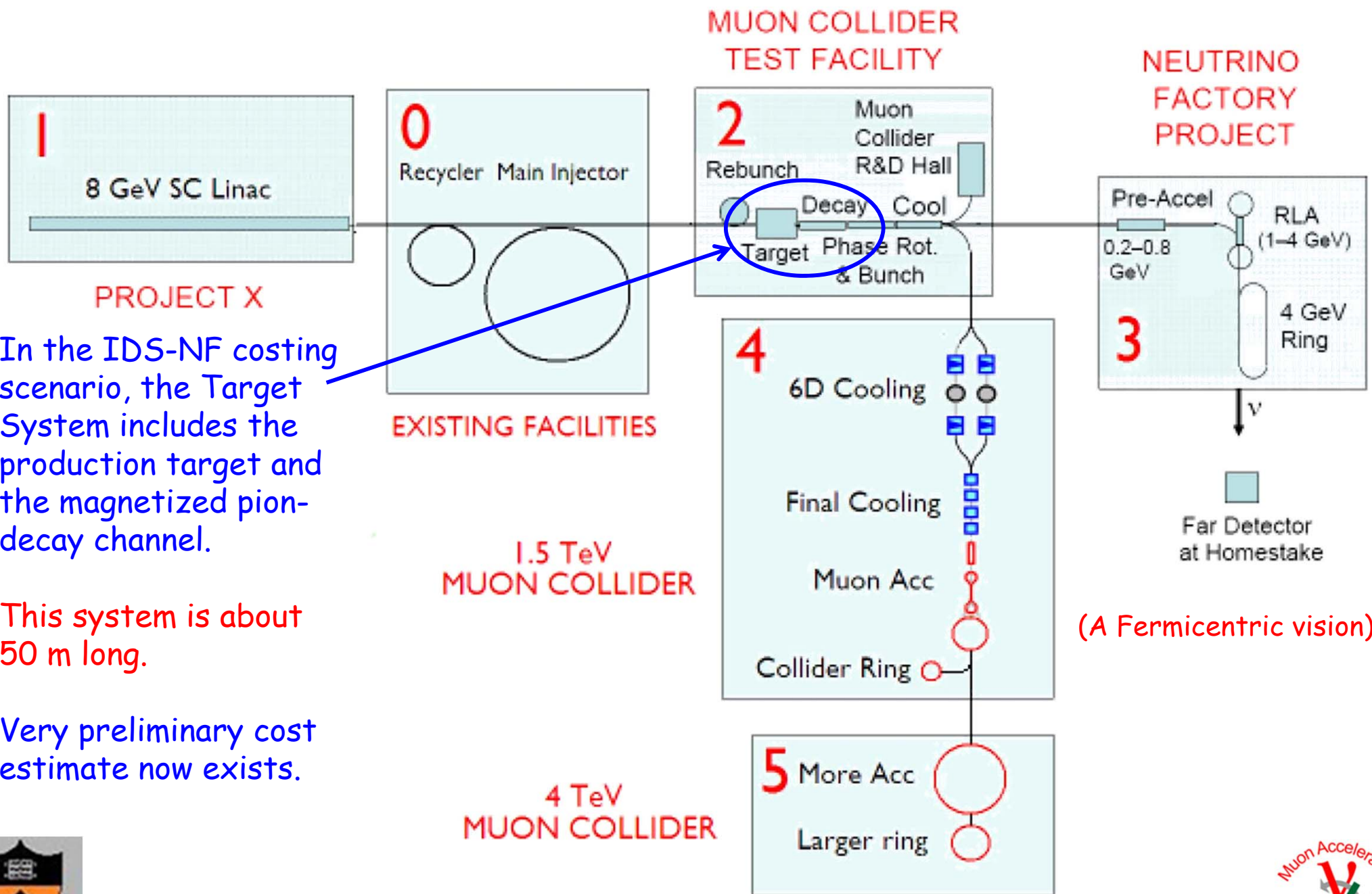

In the IDS-NF costing scenario, the Target System includes the production target and the magnetized pion-decay channel.

This system is about 50 m long.

Very preliminary cost estimate now exists.

(A Fermicentric vision)



# From A. Kurup's Costing Talk

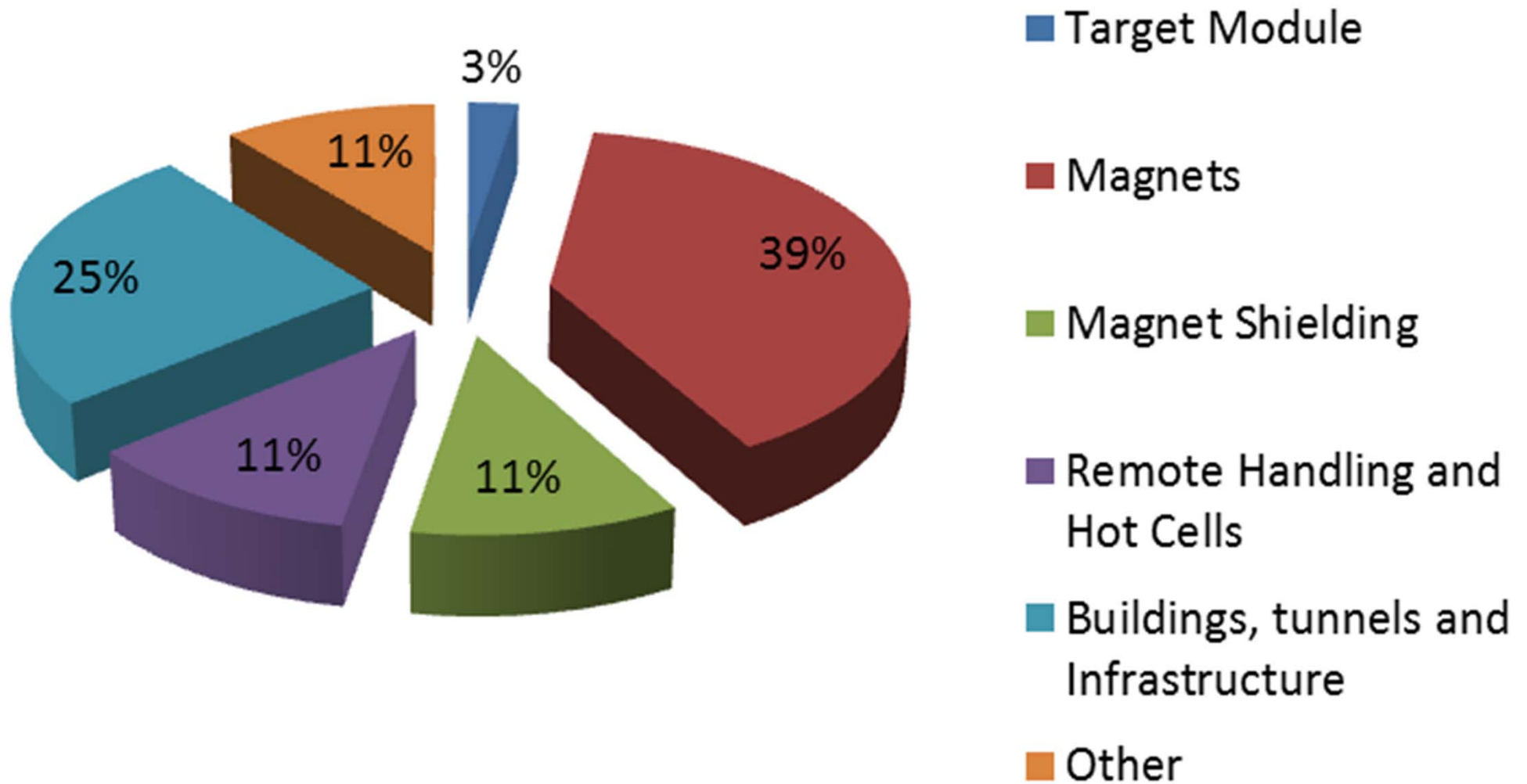

# Extract from A. Kurup's Sheet TCDCostSummary.xlsx

Name	Total Cost	Comments
Target Module	#####	Scaled from SNS
Magnets	#####	Estimated by Bob Weggel
Magnet Shielding	#####	Estimated by Bob Weggel
RF		
Quench Protection System		
Vacuum		
Cryogenics		
Diagnostics		
Controls and Interlocks		
Health and Safety		
Mechanical		
Decommissioning		
Remote Handling and Hot Cells	#####	Scaled from LBNE
Buildings, tunnels and Infrastructure	#####	Scaled from LBNE
<b>Total</b>	#####	USD



# Target and Capture Topology: Solenoid

Desire  $\approx 10^{14}$   $\mu/s$  from  $\approx 10^{15}$  p/s ( $\approx 4$  MW proton beam)

R.B. Palmer (BNL, 1994) proposed a 20-T solenoidal capture system.

Low-energy  $\pi$ 's collected from side of long, thin cylindrical target.

Solenoid coils can be some distance from proton beam.

$\Rightarrow$   $\geq 10$ -year life against radiation damage at 4 MW.

Liquid mercury jet target replaced every pulse.

Proton beam readily tilted with respect to magnetic axis.

$\Rightarrow$  Beam dump (mercury pool) out of the way of secondary  $\pi$ 's and  $\mu$ 's.

## Present Target Concept

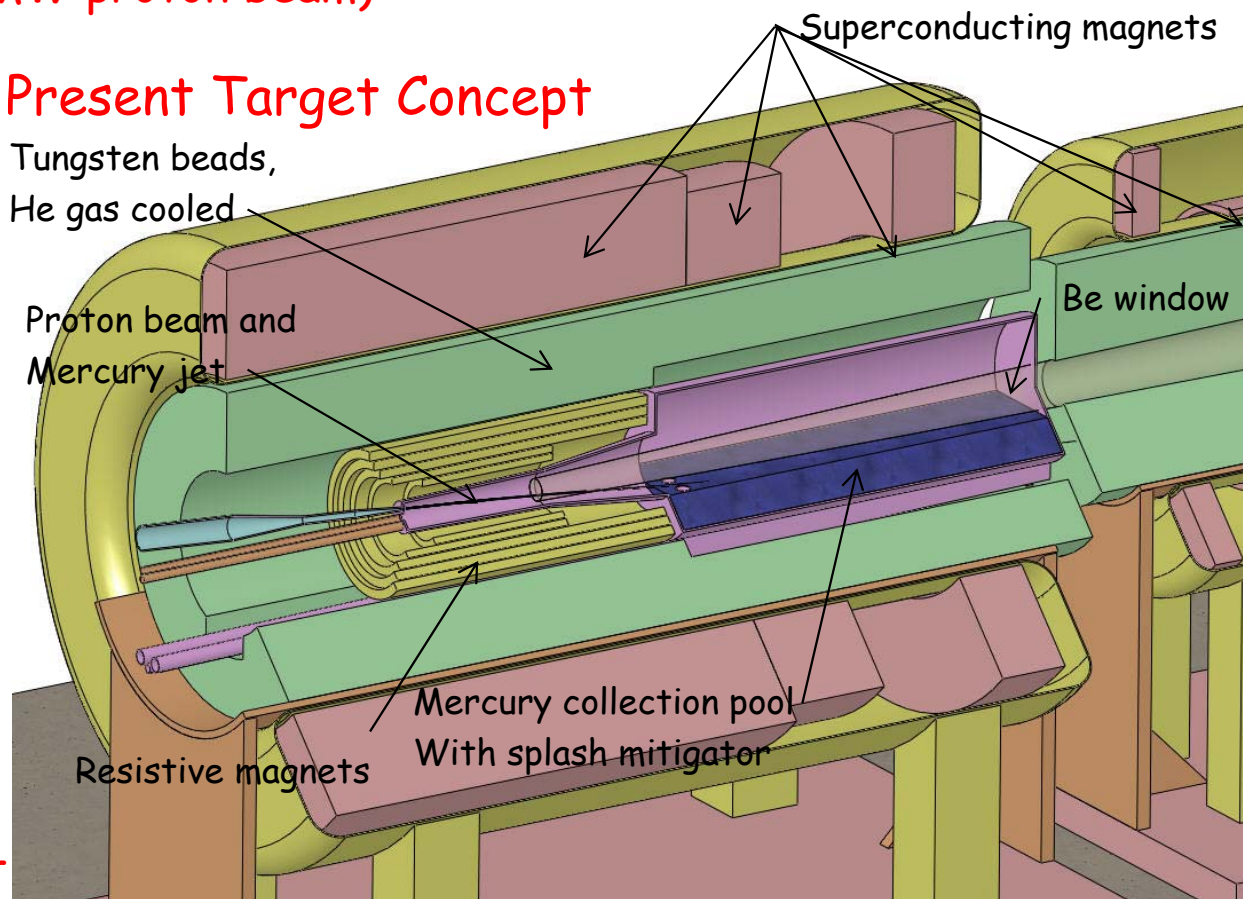

Shielding of the superconducting magnets from radiation is a major issue.

Magnet stored energy  $\sim 3$  GJ!

5-T copper magnet insert; 15-T  $Nb_3Sn$  coil + 5-T NbTi outsert.

Desirable to replace the copper magnet by a 20-T HTC insert.



# Target Module Costs Scaled from SNS (ORNL)

<b>1.06 - Target Systems</b>	<b>116,396,901</b>
1.06.01 - Target Assemblies	14,402,190
1.06.02 - Moderator Systems	8,661,901
1.06.03 - Reflector Assemblies	7,900,655
1.06.04 - Vessel Systems	11,848,901
1.06.05 - Target Station Shielding	13,405,475
1.06.06 - Target Utility Systems	10,730,099
1.06.07 - Remote Handling Systems	14,348,362
1.06.08 - Controls	3,076,899
1.06.09 - Beam Dumps	3,066,529
1.06.10 - Technical Support	12,896,977
1.06.11 - ORNL Field Coordination	16,058,914

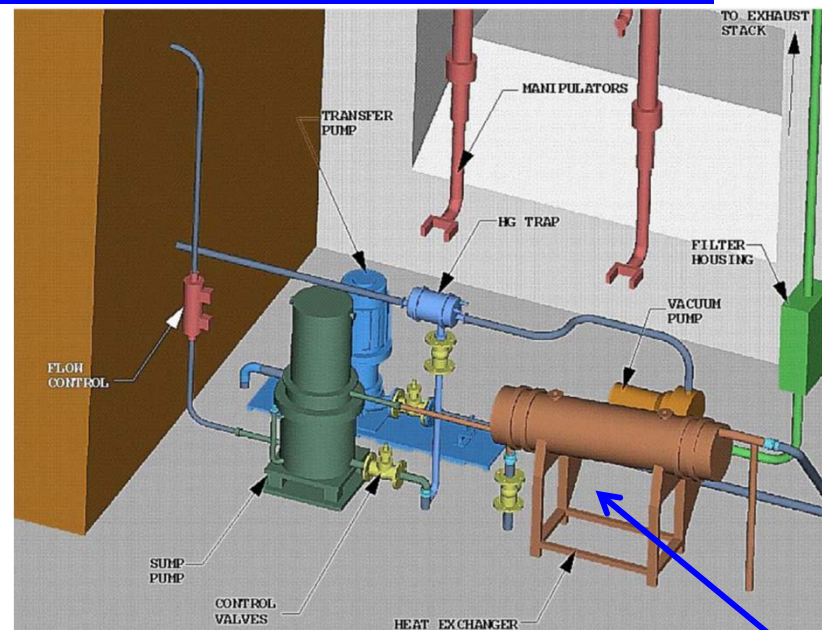

Neutrino Factory Study 2 concept

SNS/JNS Mercury target

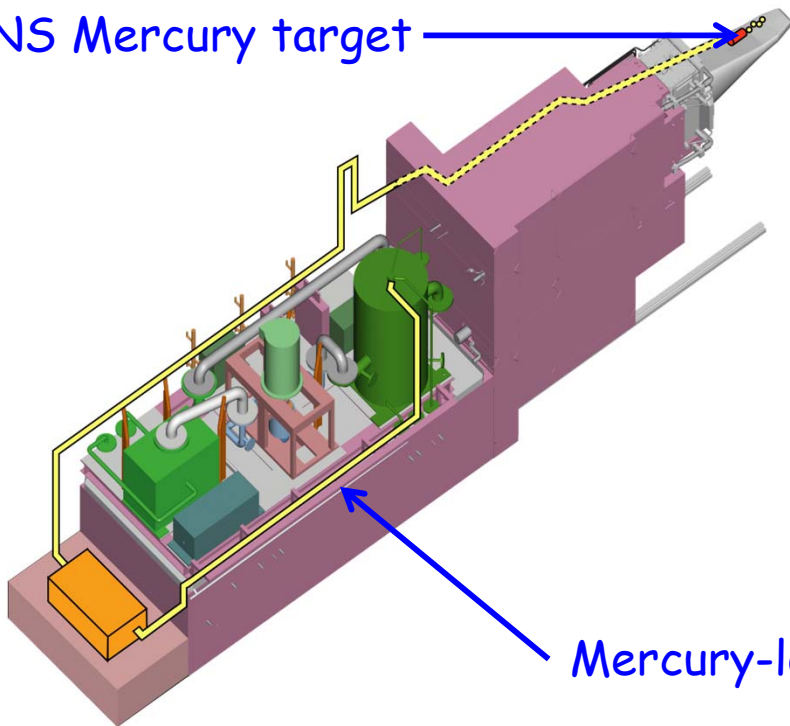

Mercury-loop utilities

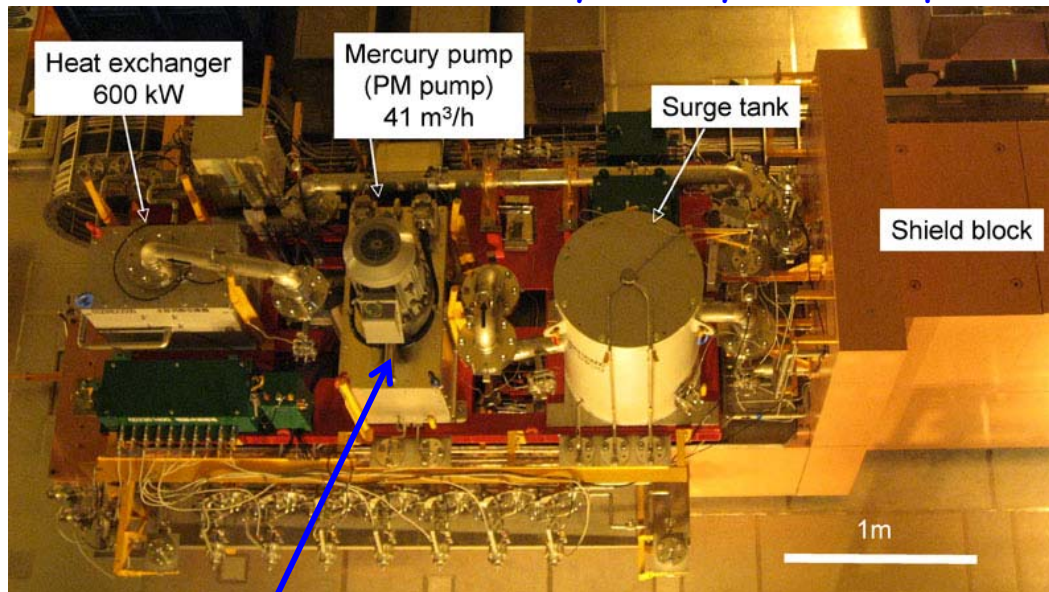

# Magnet and Shielding Costing by Bob Weggel

20-T, 120-cm-I.R. Target Magnets with Large Axial Gaps at 4, 10, 15 & 20 m

Bob Weggel, Magnet Optimization Research Engineering, LLC

3/22/2012

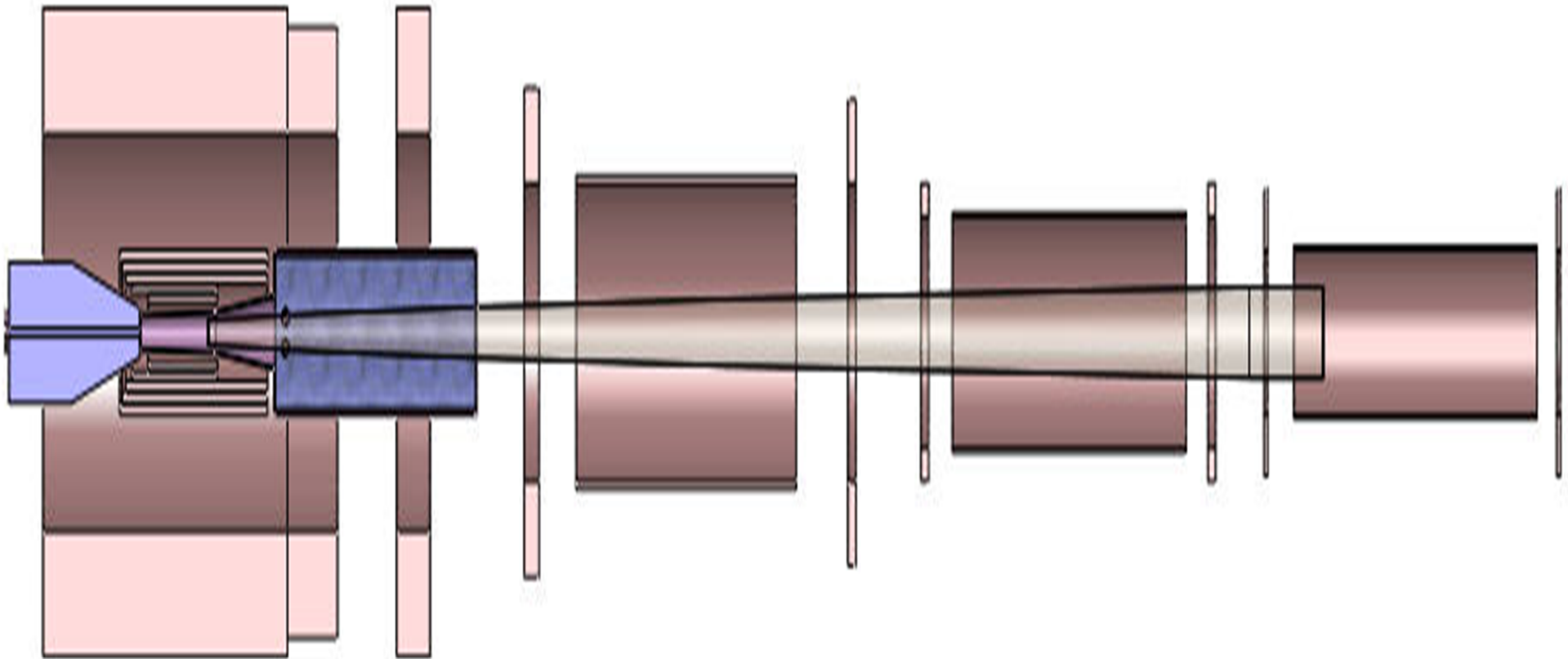

Target Magnet IDS120j: three solenoids per cryostat; large axial gaps at  $z = 4, 10, 15$  &  $20$  m [drawing courtesy Van Graves]. Target Magnet IDS120k is very similar, but the outboard solenoids in all cryostats except the first are of optimized (larger) inner radius, to improve field profile.  $U = 3.34$  GJ.



## Selected Parameters of Target Magnet IDS120k

	12.47	kA	0.1	meters	$\Delta L_{elec}$	1.724	$\mu\Omega\text{cm}$ at 20 °C	7.0	n $\Omega\text{cm/deg}$	10.0	°C T <sub>0</sub>	40.0	atmospheres $\Delta P$	0.10m	$\Delta L_{hy}$						
				Cu 1	Cu 2	Cu 3	Cu 4	Cu 5	SC 1	SC 2	SC 3	SC 4	SC 5	SC 6	SC 7	SC 8	SC 9	SC 10	SC 11	SC 12	
Coil designation	Units																				
SSt shell thickness	cm			0.255	0.325	0.183	0.160	0.145													
Current density $j_{\lambda\text{-coil}}$	kA/cm <sup>2</sup>	5.00		2.201	2.074	1.412	1.204	1.059	1.931	2.176	2.673	3.346	4.122	4.072	4.503	4.666	4.645	4.645	4.645	4.645	
Coil length	cm			100.2	123.6	207.2	212.0	215.6	352.3	77.78	45.20	31.23	255.4	15.45	13.00	341.3	10.96	14.12	320.3	14.12	
Gap between coils	cm								0.00	87.30	148.6	74.28	83.20	105.0	37.31	27.89	70.76	39.71	39.71	72.00	
Upstream end	cm			-87.6	-111.0	-121.0	-125.8	-129.5	-240.9	111.4	276.5	470.2	575.7	914.3	1035	1085	1454	1536	1590	1950	
Downstream end	cm			12.6	12.6	86.2	86.2	86.2	111.4	189.2	321.7	501.5	831.1	929.8	1048	1426	1465	1550	1910	1964	
Inner radius	cm			18.34	23.85	29.58	36.21	43.30	120.0	120.0	120.0	120.0	89.65	118.3	72.36	69.92	69.94	71.88	50.08	71.88	
Radial depth of conductor	cm			4.760	4.903	5.943	6.435	6.861	75.83	64.34	75.83	55.63	4.155	52.02	14.55	2.456	16.45	18.12	2.334	18.12	
Outer radius	cm			23.10	28.76	35.52	42.64	50.16	195.8	184.3	195.8	175.6	93.81	170.3	86.91	72.38	86.39	90.00	52.42	90.00	
Volume, inc. SSt shell	m <sup>3</sup>	39.93		0.066	0.108	0.260	0.347	0.444	26.51	4.79	3.40	1.61	0.61	0.73	0.09	0.37	0.09	0.13	0.24	0.13	
Maximum on-axis field	T			20.22	19.01	17.89	16.88	15.97	15.13	13.54	8.29	4.77	3.58	2.17	1.90	1.77	1.53				
SC $\gamma$ , MPa & fr.	6.00	none	0						0.093	0.070	0.029	0.018	0.017	0.011	0.011	0.011	0.010	0.010	0.010	0.010	
Cu $\gamma$ , MPa & fr.	8.95	100	0	0.550	0.550	0.550	0.550	0.550	0.154	0.174	0.214	0.268	0.330	0.326	0.360	0.373	0.372	0.372	0.372	0.372	
SSt $\gamma$ , MPa & fr.	7.80	700	700	0.051	0.062	0.030	0.024	0.021	0.521	0.495	0.436	0.313	0.159	0.174	0.088	0.056	0.061	0.061	0.061	0.061	
SSt cm & SC M\$	30M	\$87.5	0.000	0.256	0.326	0.183	0.160	0.145	\$74.2	\$10.0	\$2.96	\$1.76	\$0.62	\$0.49	\$0.06	\$0.025	\$0.005	\$0.008	\$0.014	\$0.008	
Coil tons	\$/m <sup>3</sup>	6.50	224.4	0.356	0.583	1.382	1.835	2.344	159.0	27.92	18.07	7.80	2.56	3.12	0.37	1.41	0.34	0.49	0.92	0.49	
M\$@\$400/kg	0.40	\$2.60	\$89.8	4	4	4	4	4	paths/layer												
Magnet MW or MA-m	77.26	86.49	1.53	2.28	2.58	2.46	2.41	51.19	10.41	9.09	5.40	2.52	2.97	0.43	1.75	0.41	0.60	1.12	0.60		

Coil dimensions are in rows 3 through 11. Anticipated for the complete magnet, but not tabulated above, are an additional seven sets of three solenoids each that repeat solenoids SC #10, SC #11 and SC #12 at multiples of 5 m, to a distance z = 50 m. The cost estimates in the columns with first-row entries “kA” and “0.1” include solenoids to z = 20 m.

The cost of each solenoid is based on its mass of superconductor (if any), copper, stainless steel and insulation. The assumed unit cost of fabricated Nb<sub>3</sub>Sn (SC #1-#3) is 30 M\$/m<sup>3</sup>; that of NbTi (SC #4 and up) is \$X M\$/m<sup>3</sup>. The assumed cost of copper, stainless steel and insulation is \$X/kg. Costs of cryostats, shielding vessels, shielding and other components have yet to be estimated.

The estimated cost of the resistive magnet is 6.50 metric tonnes x \$X/kg = \$Y M. The cost of SC#1 is the sum of two components: superconducting and non-superconducting. The non-superconducting cost is 159.0 tonnes x \$X/kg = Y M\$. The cost attributed to the superconductor is 26.51 m<sup>3</sup> x 0.093 x Y M\$/m<sup>3</sup> = Z M\$, for a total of \$X. M\$.

The non-superconducting unit cost of \$X/kg compares to the \$Y/kg reported for resistive magnets at the National High Magnetic Field Laboratory (NHMFL) at Tallahassee, Florida. The superconducting unit cost of Z M\$/m<sup>3</sup> approximately doubles the non-superconducting unit cost a superconducting magnet. The average unit cost for all the superconducting magnets is X M\$ / 224.4 tonnes = \$Y/kg. This compares with the \$Z/kg reported for superconducting and hybrid magnets at the NHMFL.

Weggel's cost estimate agrees to within 2% with the Green-Strauss algorithm (A. Bross).





# Target Hall

A major cost driver will be civil construction and shielding.

LBNE 2-MW target station  
~ \$175m

Crude sketch to start IDS-NF costing

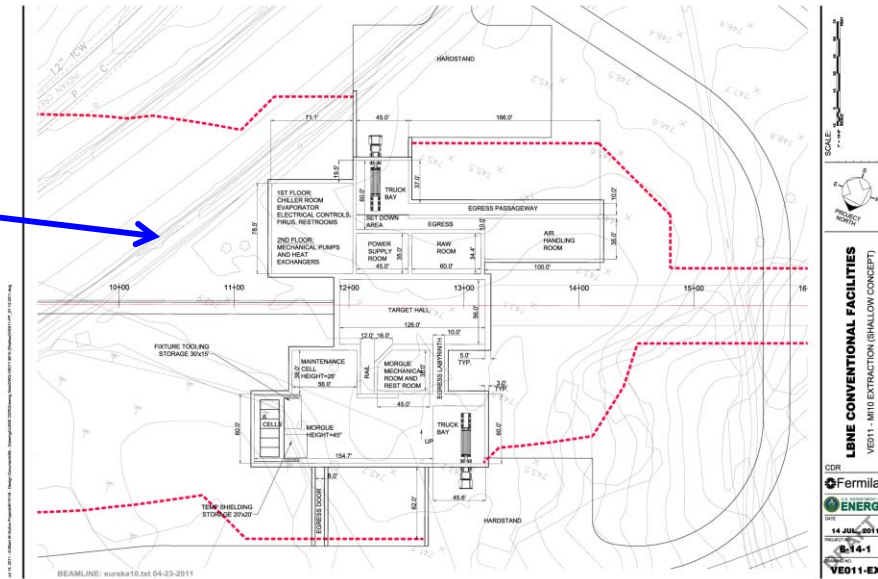

NuMI target hall

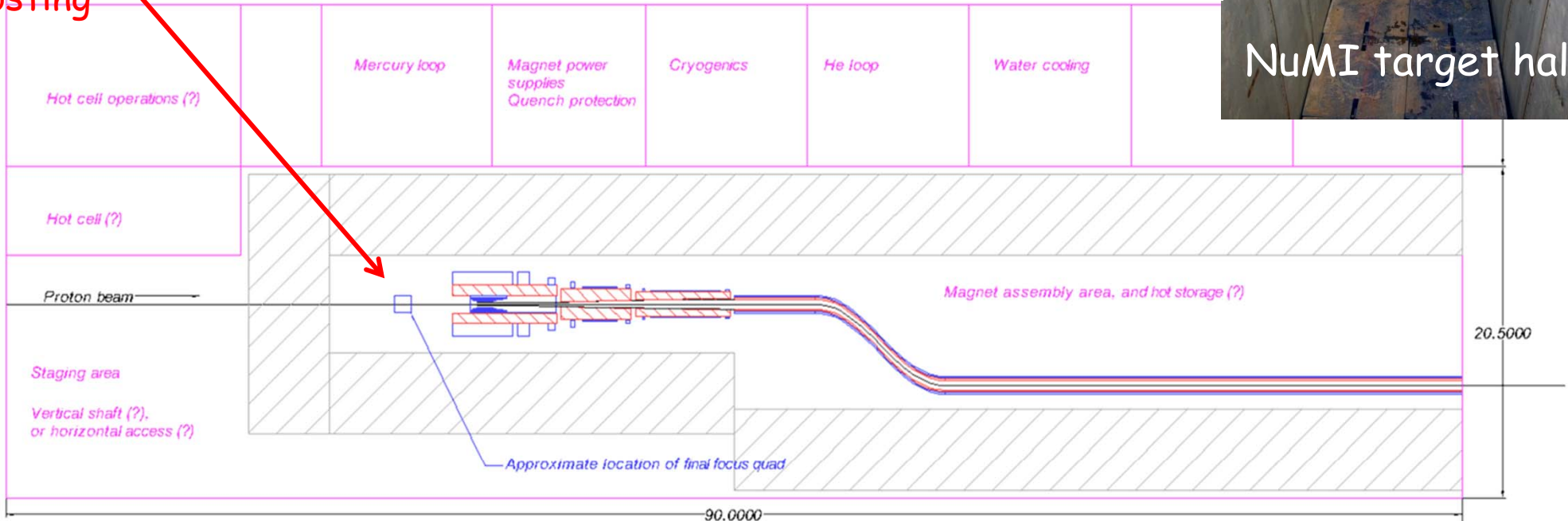

Concrete shielding assumed to be 5 m thick, => floor also 5 m thick, and 5 m shielding above the beamline  
50 ton bridge crane, hook height ~ 10 m, => building height ~ 15 m



# Neutrino Factory Study 2 Concepts

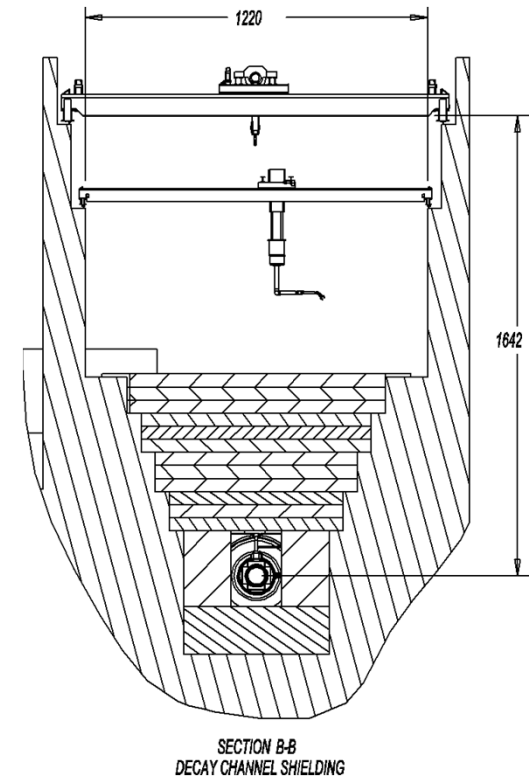
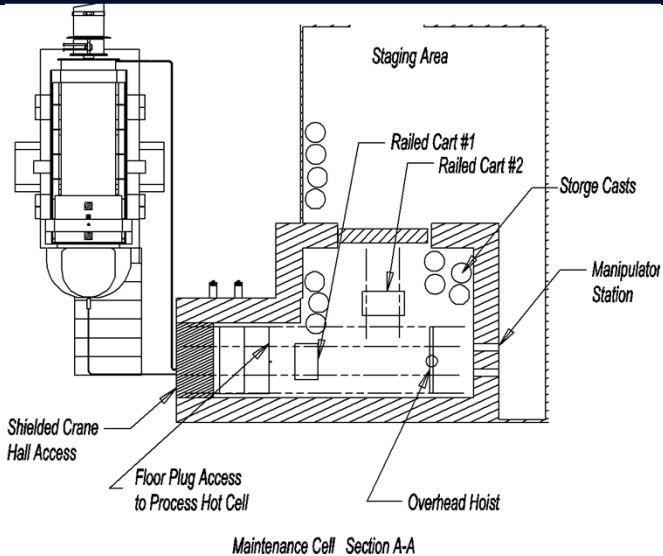
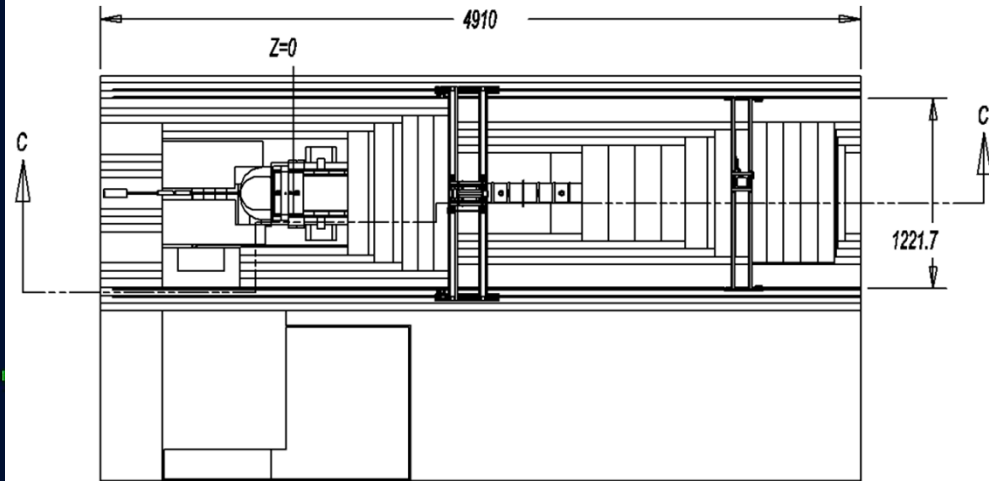
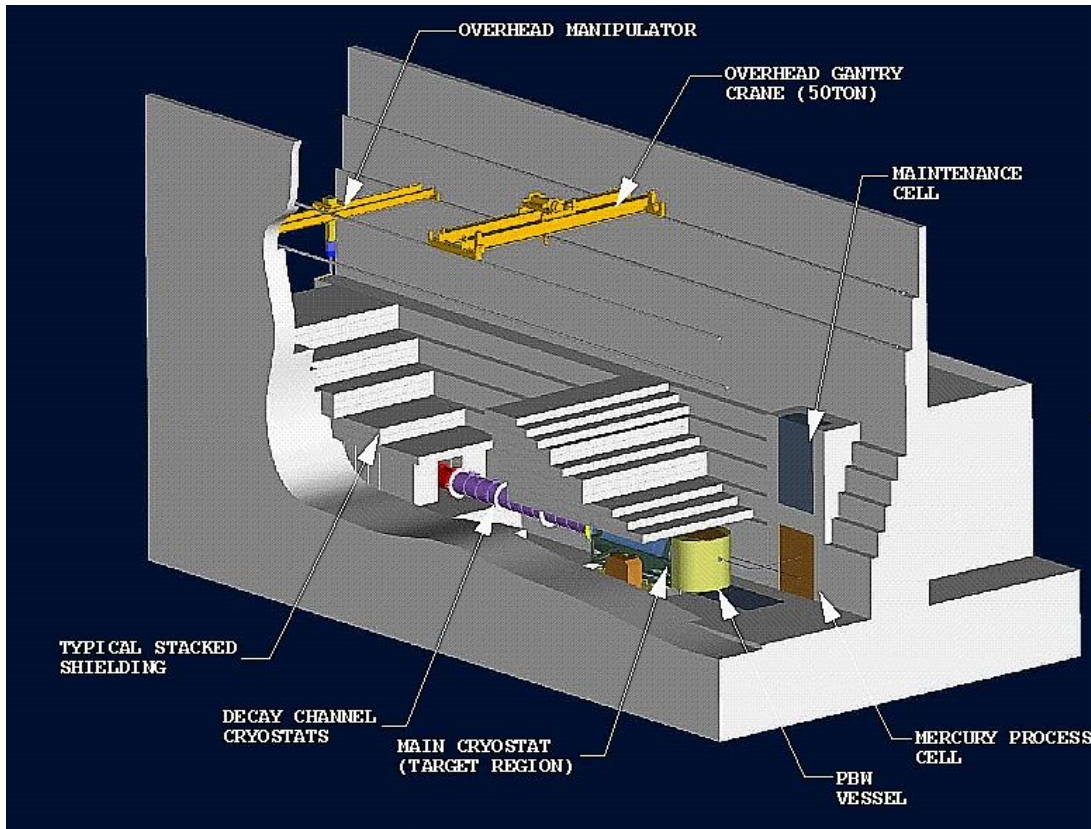

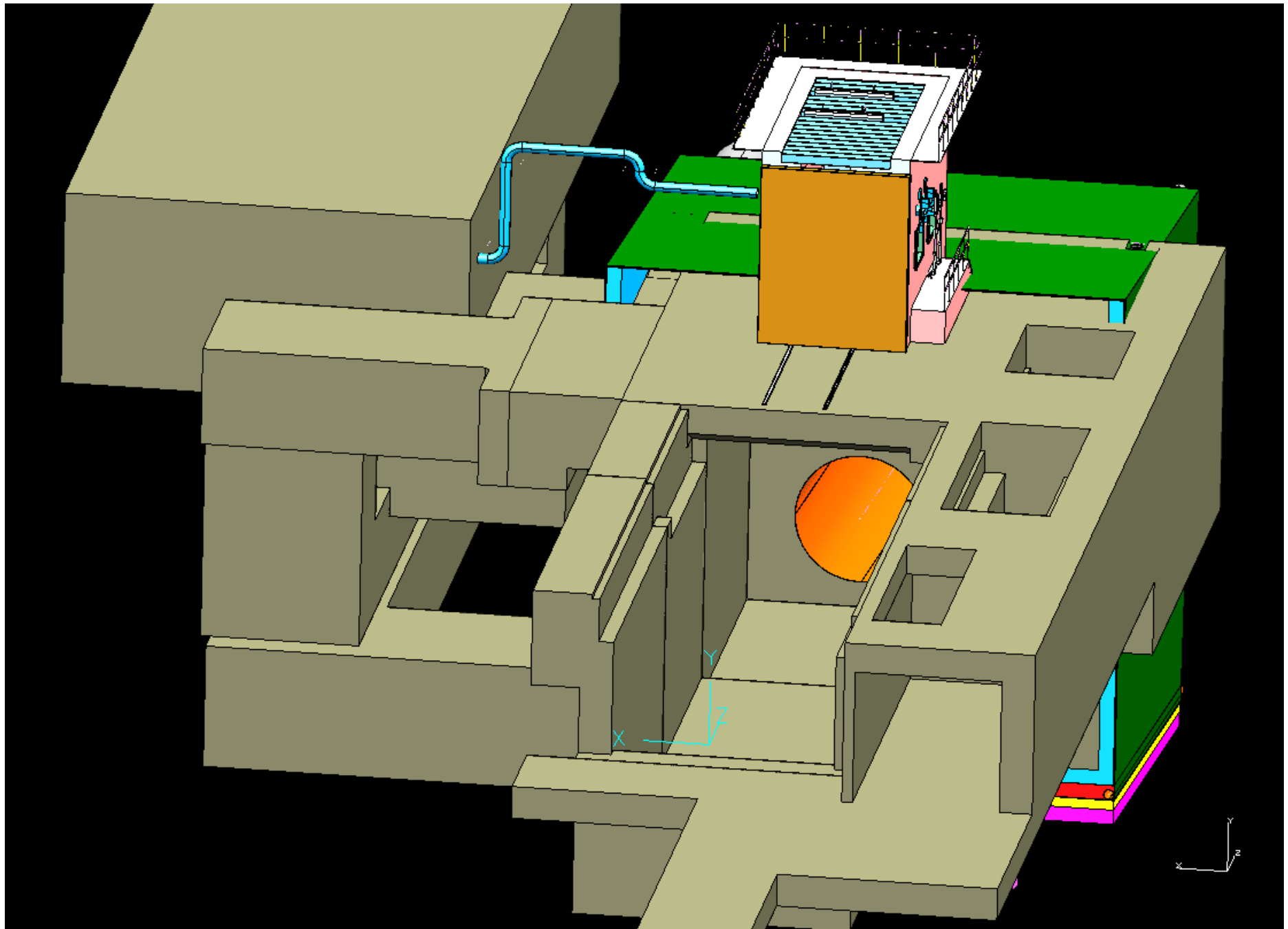

## LBNE Target Hall Concept



# LBNE 20 – TARGET COMPLEX Site Plan

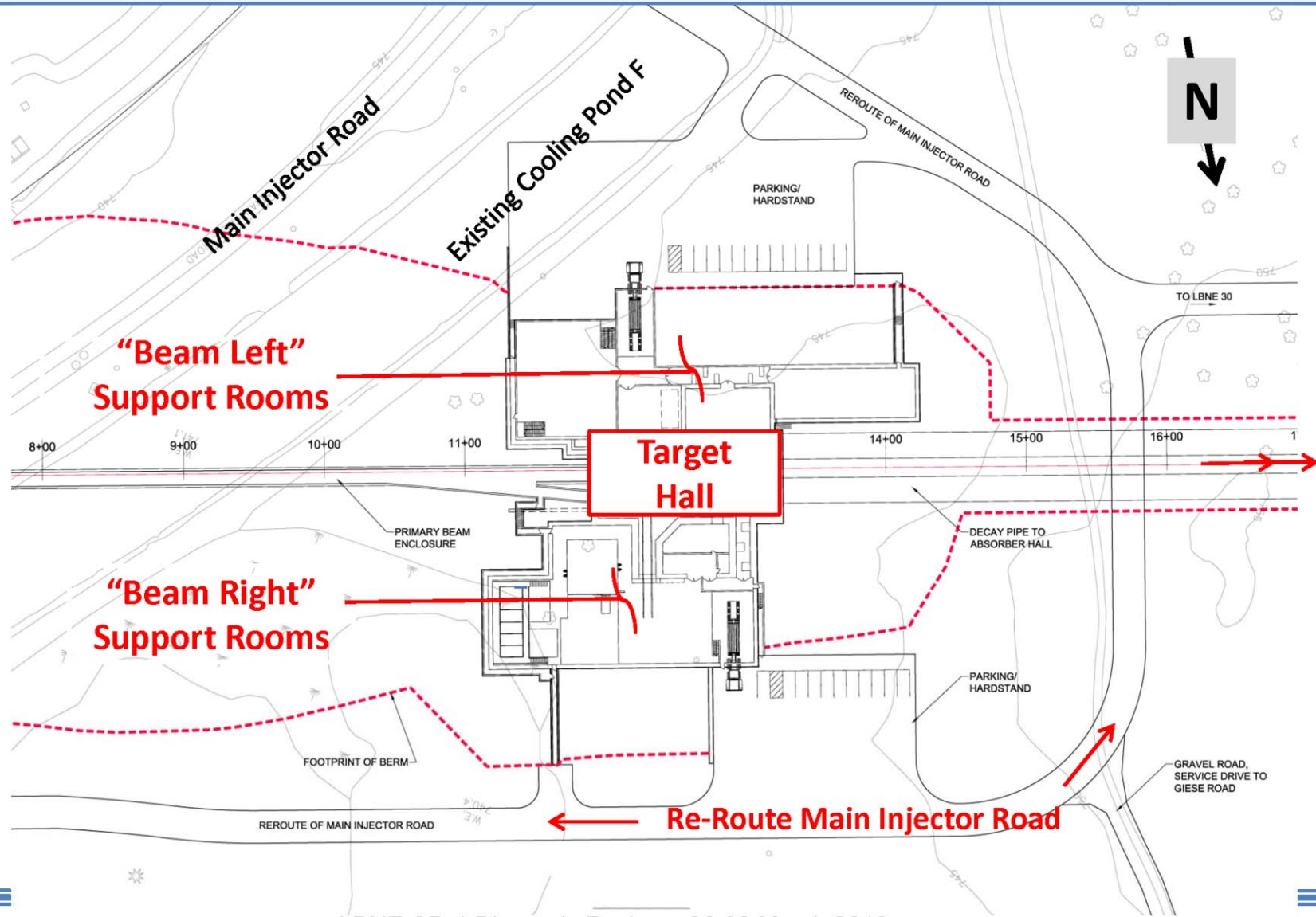

LBNE CD-1 Director's Review - 26-30 March 2012

15





# “Beam Left” Service and Support Rooms

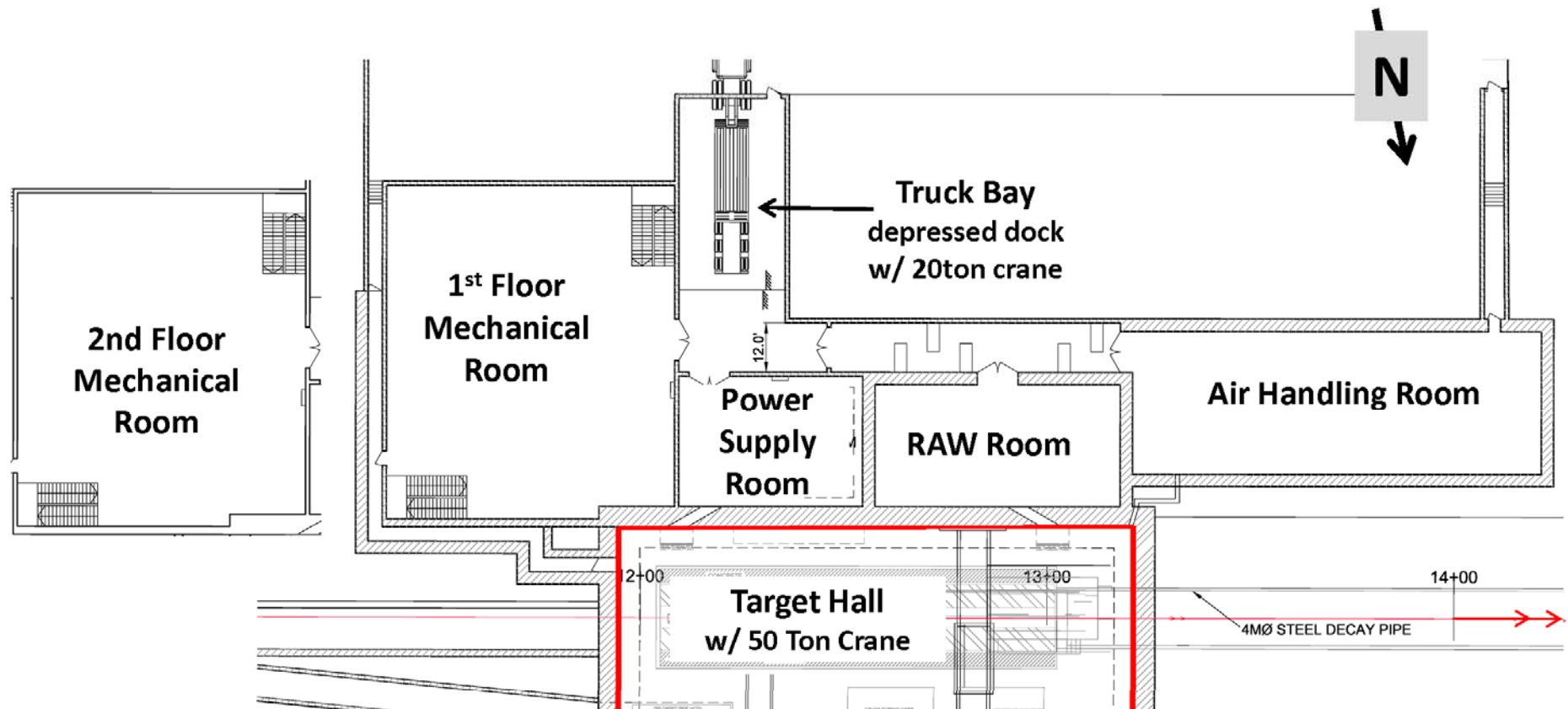

**Power Supply Room, RAW Room, Air Handling Room,  
Truck Bay, 2 Story Mechanical Wing**

LBNE CD-1 Director's Review - 26-30 March 2012

17



# “Beam Right” Service and Support Rooms

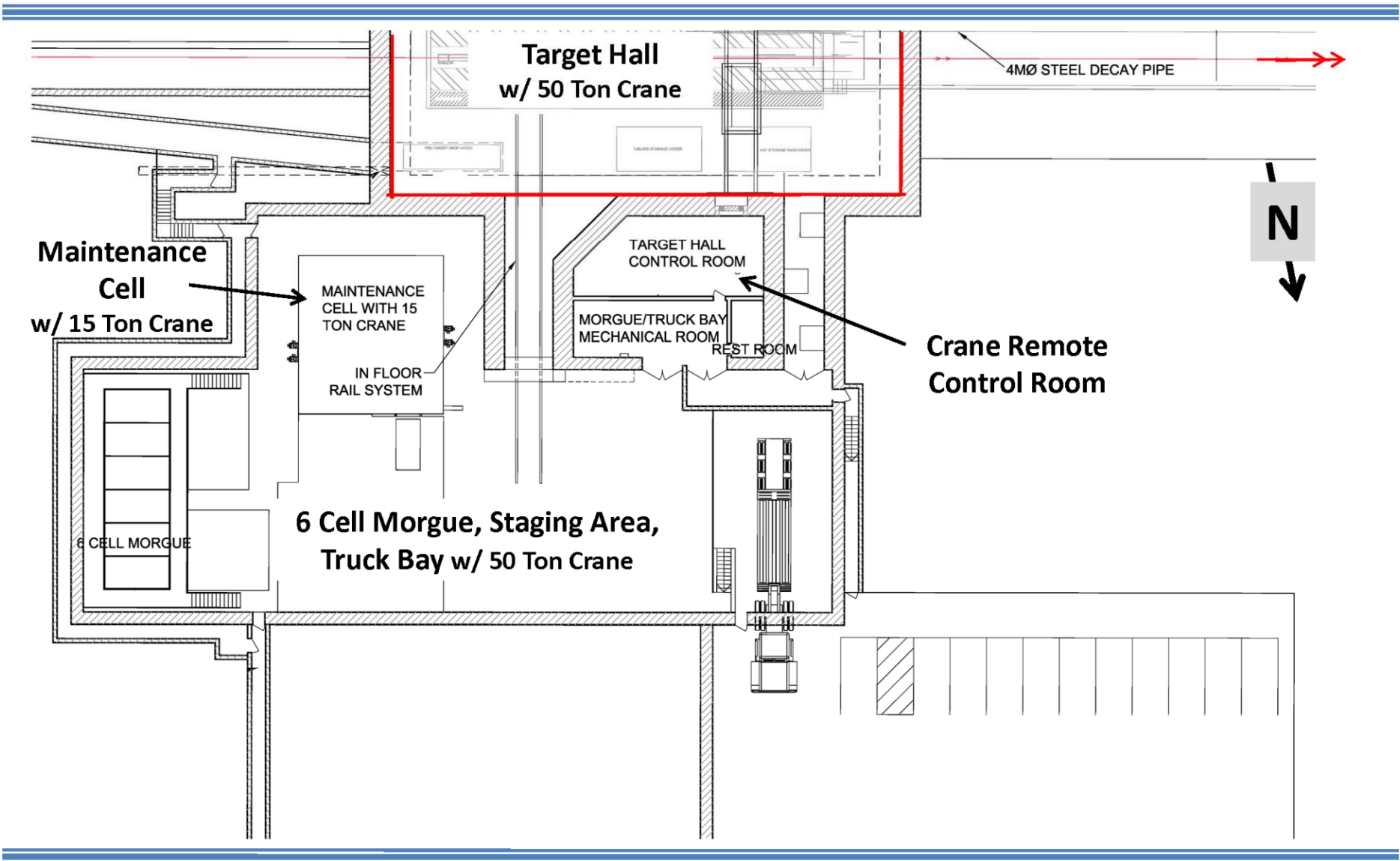

LBNE CD-1 Director's Review - 26-30 March 2012

18



# Decay Pipe

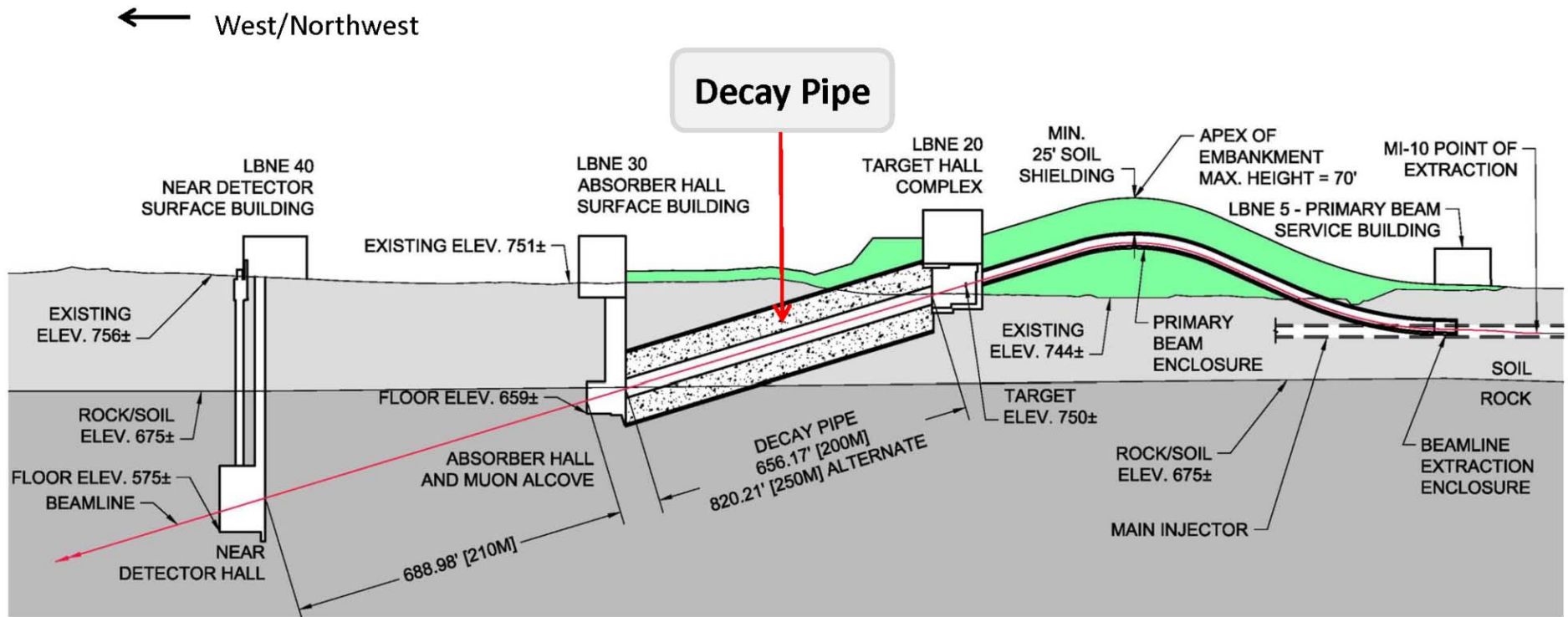

scale  
H : V  
1.0 : 0.33

The NF Target System Hall is equivalent in many ways to the LBNE Decay Pipe.



# Decay Pipe Cross Section

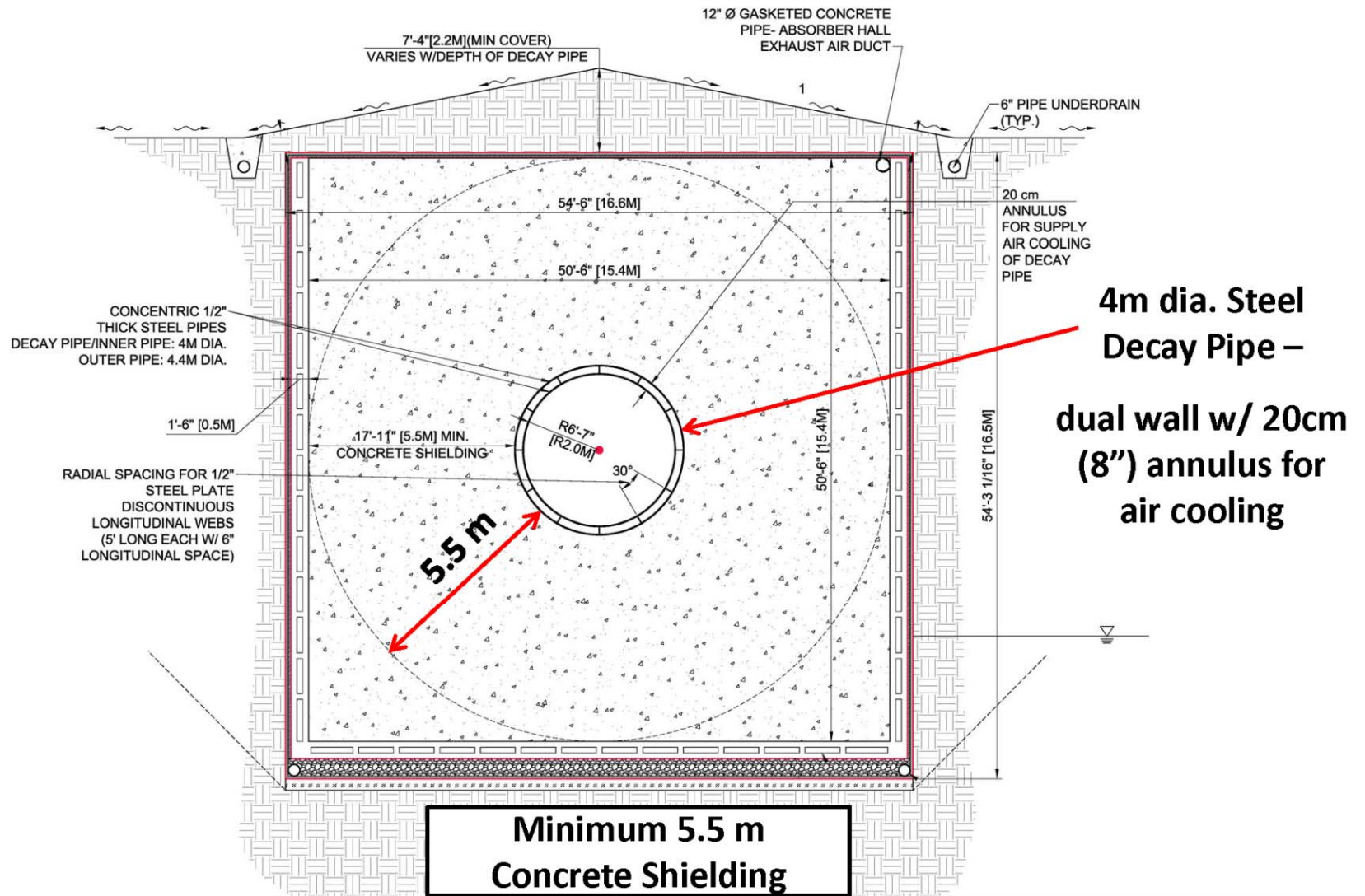

LBNE CD-1 Director's Review - 26-30 March 2012

36

We may need concrete shielding ~ 5.5 m thick around the entire target system.

# Decay Pipe Air Cooling Ducting at Target Hall

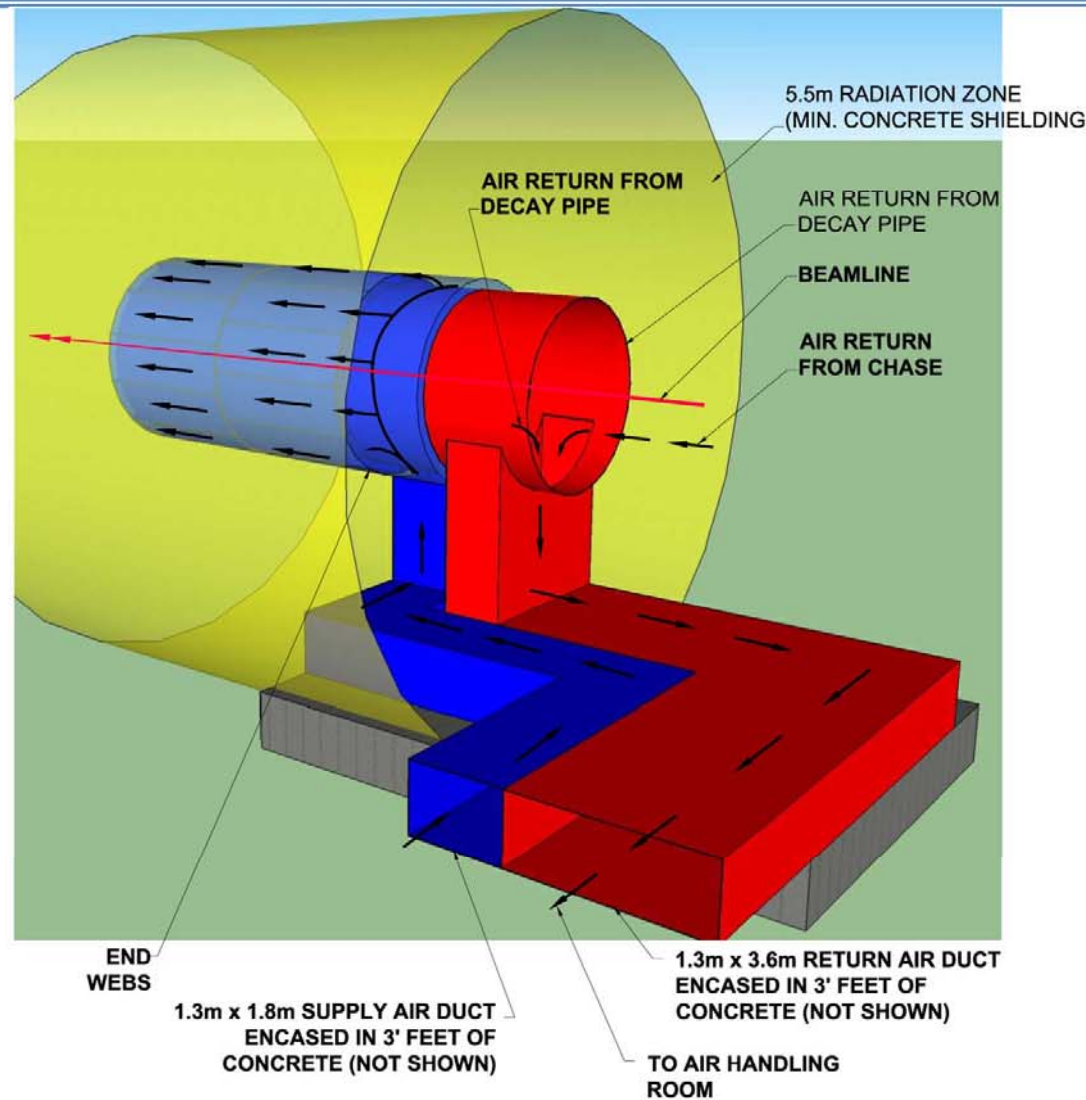

LBNE CD-1 Director's Review - 26-30 March 2012

37

We must have an activated-air handling system for the Target System Hall.

