

Development of High Powered Target Systems for the Spallation Neutron Source and the Muon Collider/Neutrino Factory

**T. Gabriel, J. Haines,
B. Riemer, P. Spampinato
N. Mokhov, T. McManamy**

April 2002

The Spallation Neutron Source



- **World's most powerful neutron science facility.**
- **\$1.4B project**
- **Completion in 2006**
- **Pulsed proton beam from Linac/Ring creates neutrons by spallation reaction with mercury target.**



- **Partnership of six laboratories under direction of the ORNL SNS Project Office.**

SNS Basic Parameters List



- **Beam power** **>1 mW**
- **Beam energy** **~1 GeV**
- **Pulse rate** **60 hertz**
- **Pulse length** **<1 μ s**
- **Energy per pulse** **>17 kJ**
- **Target/Instrument building** **1**
- **Maximum number of neutron scattering instruments** **24**

Excellent Progress at the Construction Site



02-01977/arb

The Accelerator Configuration will include a SuperConducting RF System

The Accelerator Configuration has been established and the high-energy end of the Linac will feature a SuperConducting RF System.

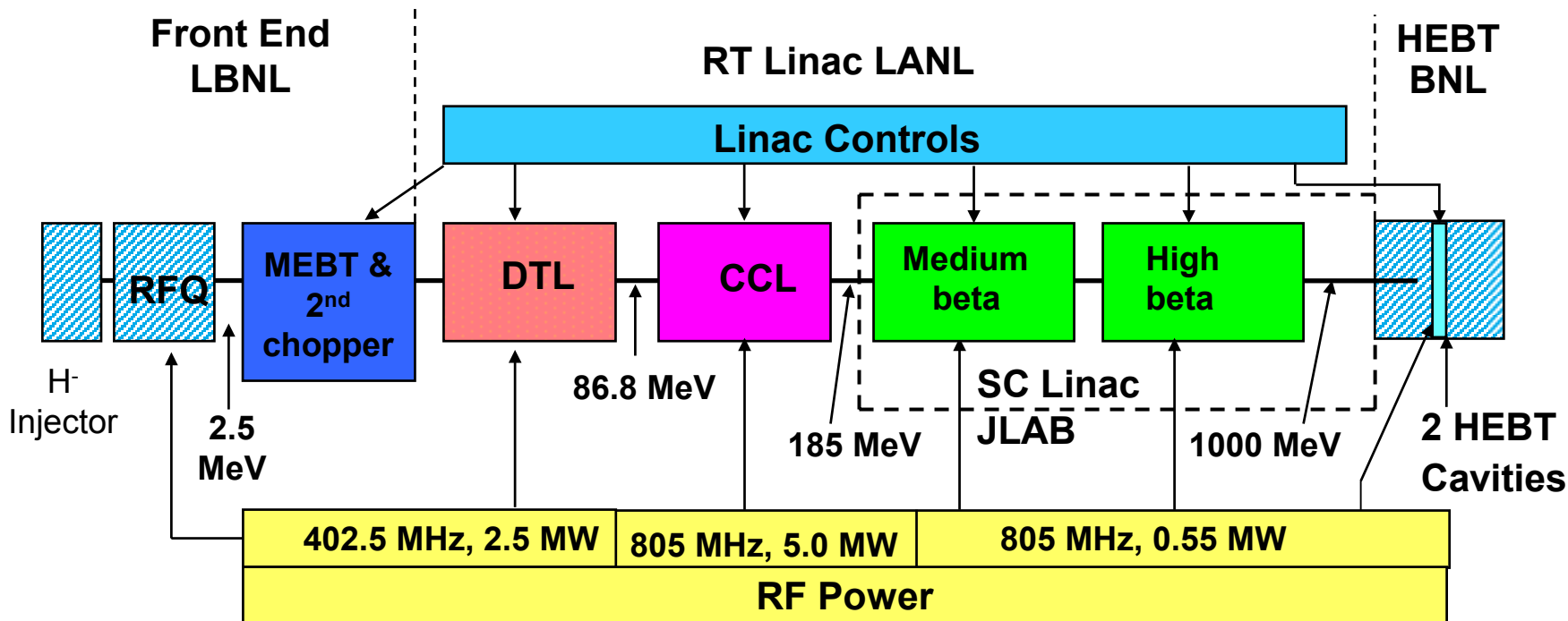

The SNS High Power Target Building Is Becoming a Reality

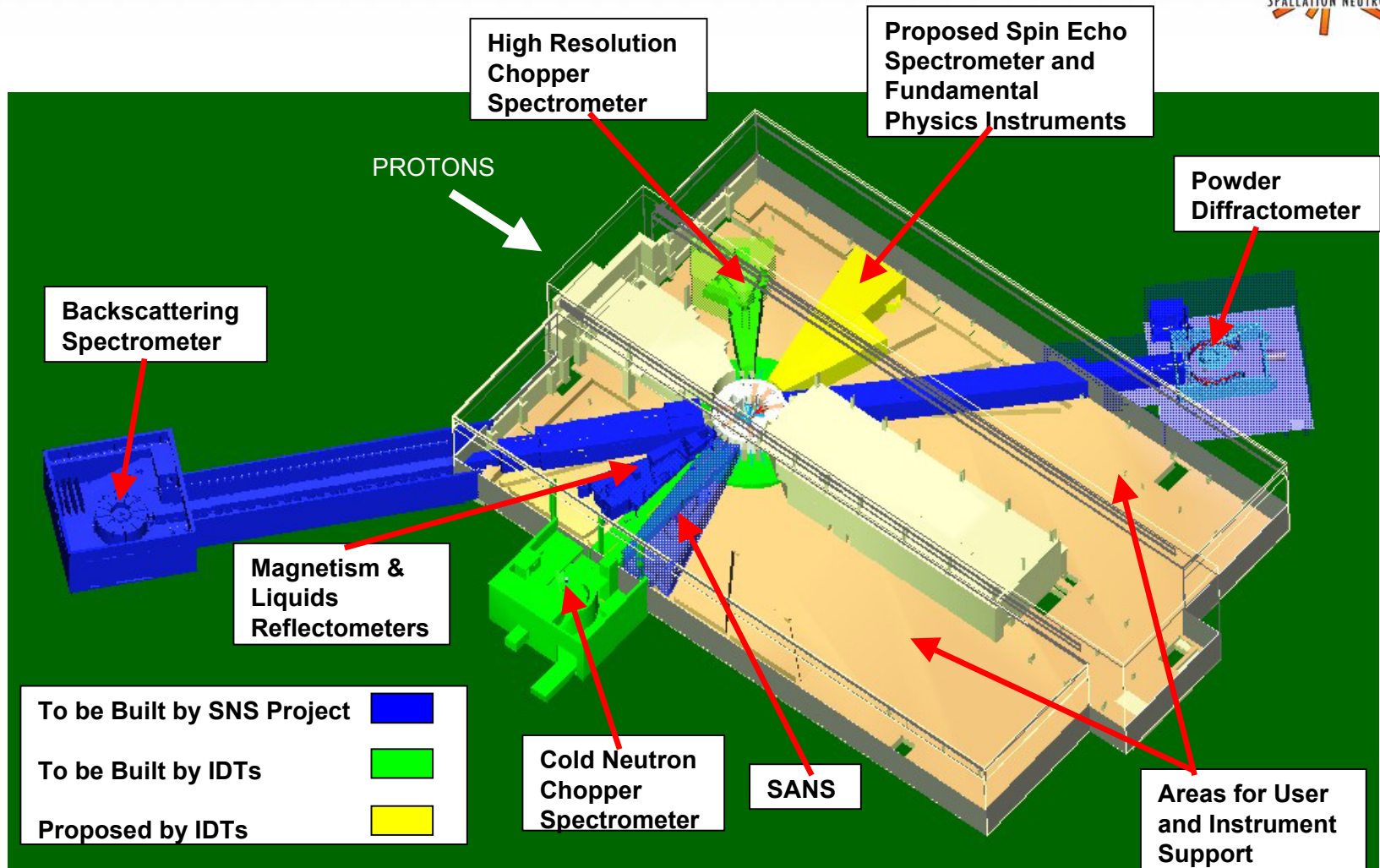

All of the supporting piles have been placed into the ground, rebar is being placed, and concrete is being poured.

Monolith Region Without Target Cart and Process Bay Equipment in Hot Cell with Target Cart Extracted

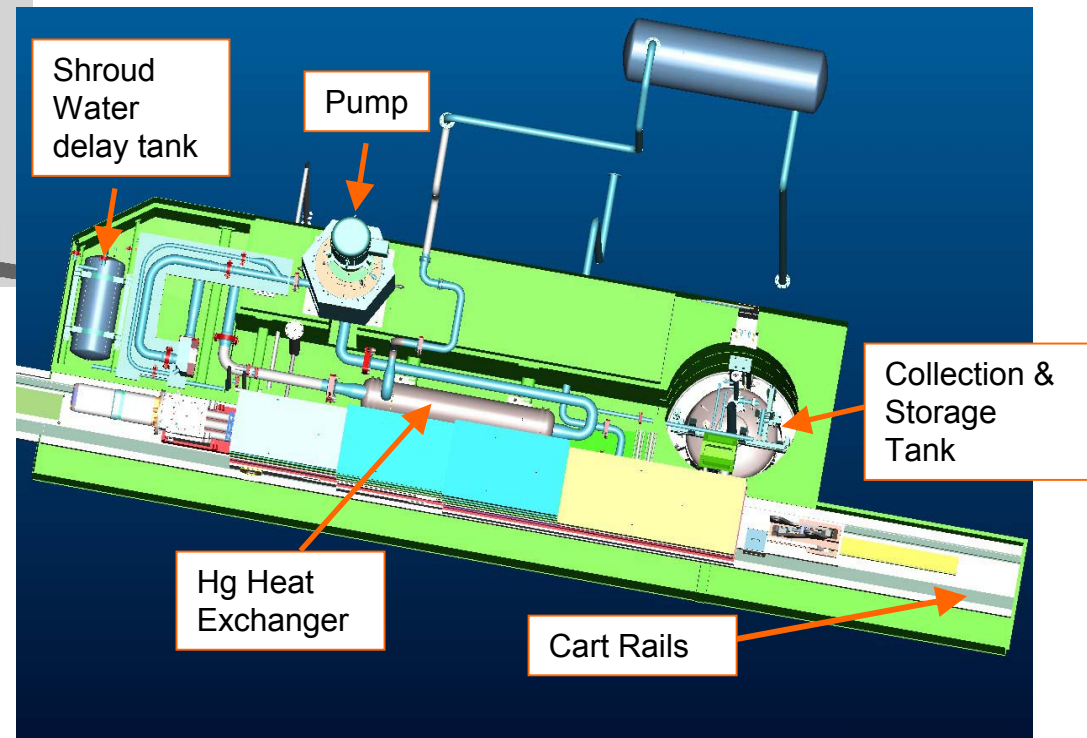
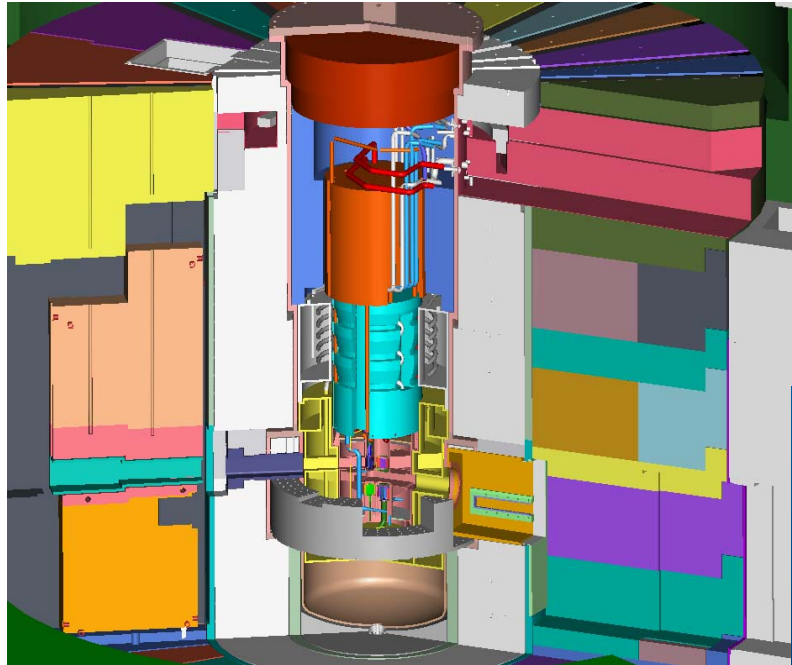

Key Issues For The SNS Mercury Target



- **Steady state power handling**
 - Cooling of target/enclosure window - wettability
 - Hot spots of Hg caused by recirculation around flow baffles
- **Demonstration of key systems:**
 - Mercury loop operation
 - Remote handling
- **Radiation damage to structural materials**
- **Compatibility between Hg and other target system materials**
- **Thermal Shock**
 - Pressure pulse loads on structural material
 - Effects on bulk Hg flow

Mercury Target Development Has 3 Major Facilities at ORNL and Utilizes the Accelerator Facilities at LANL/WNR and BNL/AGS

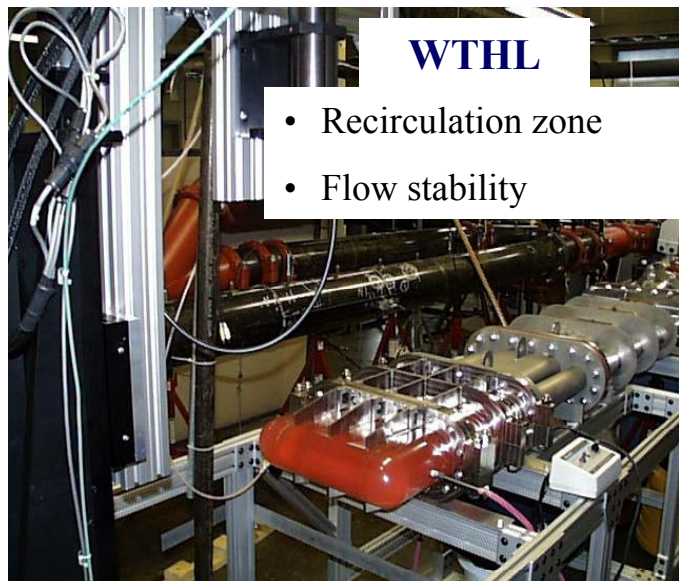

WTHL

- Recirculation zone
- Flow stability



MTHL

- Wettability
- Design data for target window
- Corrosion/erosion test



TTF

- Final CFD benchmark
- Verify Hg process equipment
- Operational experience

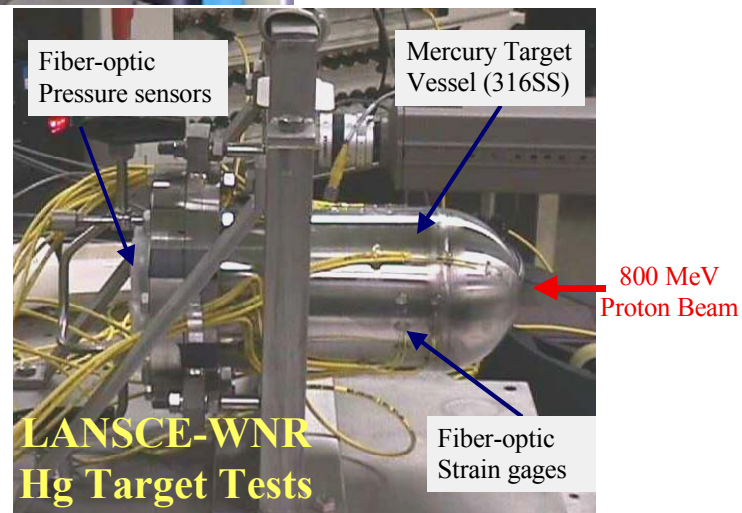

LANSCE-WNR Hg Target Tests

Potential Pitting Problem Addressed in Recent Tests

- Pitting of stainless steel surfaces in contact with Hg observed by JAERI team in off-line mechanical pressure pulse tests.
 - Is this relevant to loads induced by pulsed proton beam?
- Two Hg targets were exposed to 200 pulses each during July 23-25 tests at LANSCE-WNR facility.
 - Currently examining internal surfaces of target and test coupons to look for pitting.
 - Energy density same as SNS at 2 MW (2.8×10^{13} protons/pulse, 800 MeV protons, beam $\sigma \sim 10$ mm).

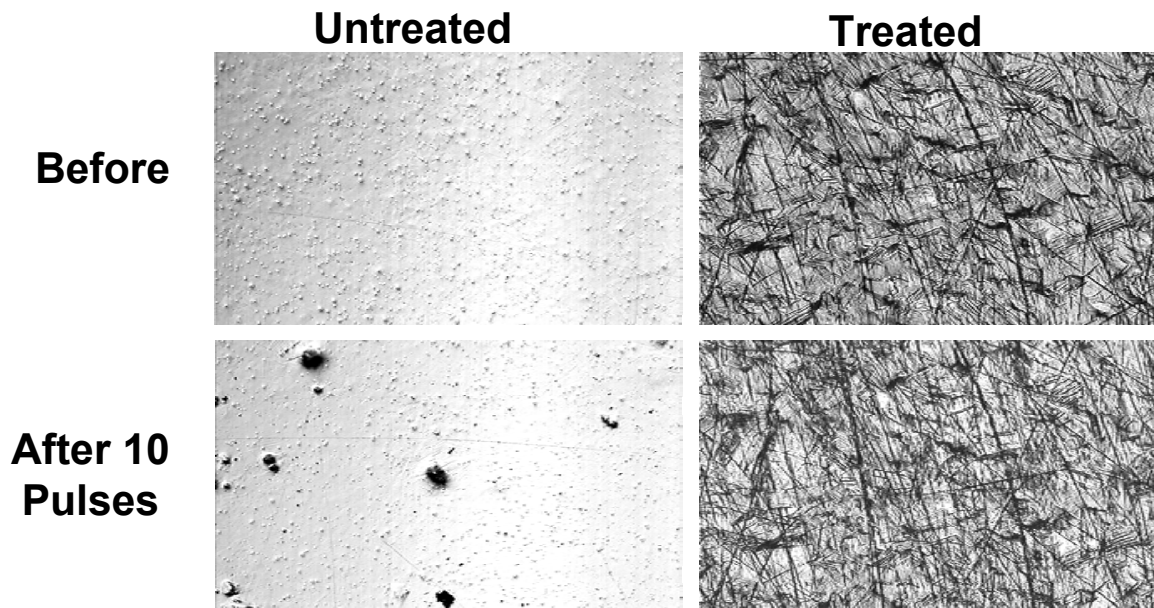

From H. Kogawa (JAERI)

Configuration for WNR “Blue Room” Tests

- These tests were originally designed for helping calibrate models for predicting strain.

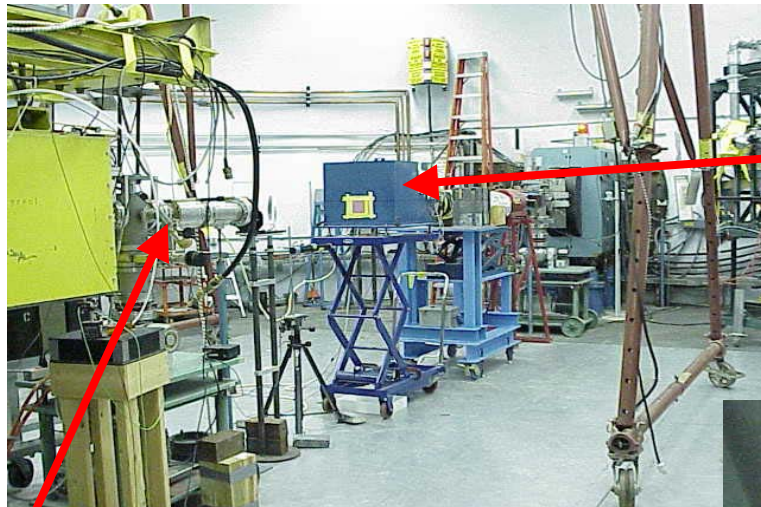

Secondary container

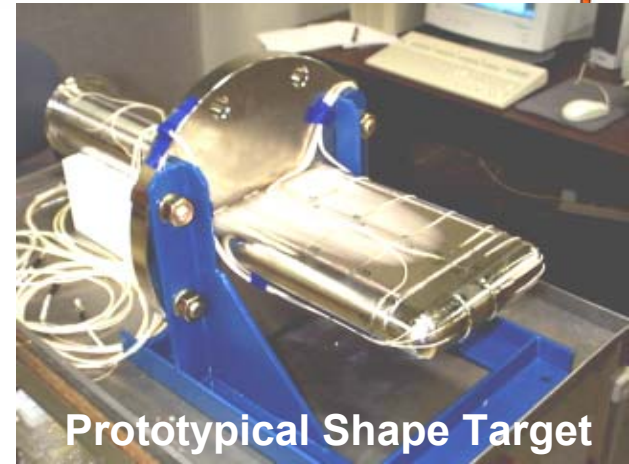

Prototypical Shape Target



microphone

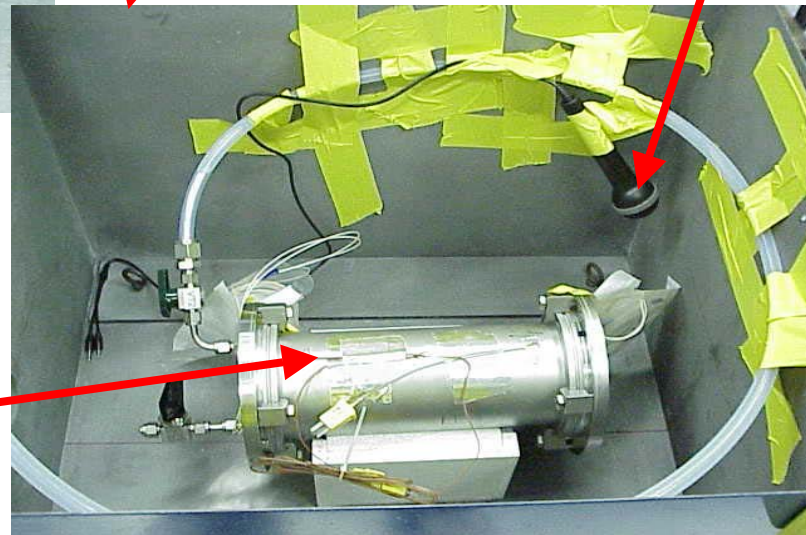

800 MeV proton beam duct

Cylindrical target with thin diaphragms (instrumented with fiber-optic strain sensors)

Large Pits Were Found Near the Center of the Thin Diaphragms



Results from Initial Visual Inspection of December 2001 Test Targets



- **Rectangular target with small Hg layer in front.**
 - Large pits on both surfaces of small Hg layer.
 - No large pits on both walls of bulk Hg region.
 - Possible causes:
 - Acoustic impedance mismatch at steel/air interface causes cavitation in first Hg layer/protects bulk Hg region.
 - Non-axisymmetric shape eliminates focusing.
- **Cylindrical targets.**
 - Large pits found on annealed 316SS end plate of conical section.
 - Large pits found on thick Stellite, Nitronic 60 (20% cold-worked), and annealed 316SS end plates.
 - No large pits on thick, cold worked (50%) 316SS end plate that had Kolsterizing treatment.
 - Combination of small strain, stronger/harder substrate, and hard surface treatment eliminate large pits!

Two More Test Campaigns Will Address the Pitting Issue in 2002



- **ASTE tests (collaboration with ESS and Japanese) at BNL will examine coating options during April 1-7, 2002 tests.**
 - Bare annealed 316SS with and without a gas layer at the top of the target.
 - CrN coating on 316SS.
 - Non-crystalline metallic glass coating treatment on 316SS (INEEL process).
- **WNR tests planned for July 2002 will examine:**
 - Pitting threshold.
 - Simple mitigation schemes such as providing a water layer instead of a Hg layer in the front of the target.
 - Any schemes found to be promising after further examining December 2001 specimens.

Neutrino Factory/Muon Collider Target/Capture Facility

A Conceptual Design for a Target and Support Facility has been Developed for the Facility

- Hg Jet Target (Graphite target).
- 16-24 GeV protons, 1-4 MW on Target.
- Hybrid solenoid system (*National High Magnetic Field Laboratory*).
- Decay channel.
- Nuclear shielding.
- Remote handling.

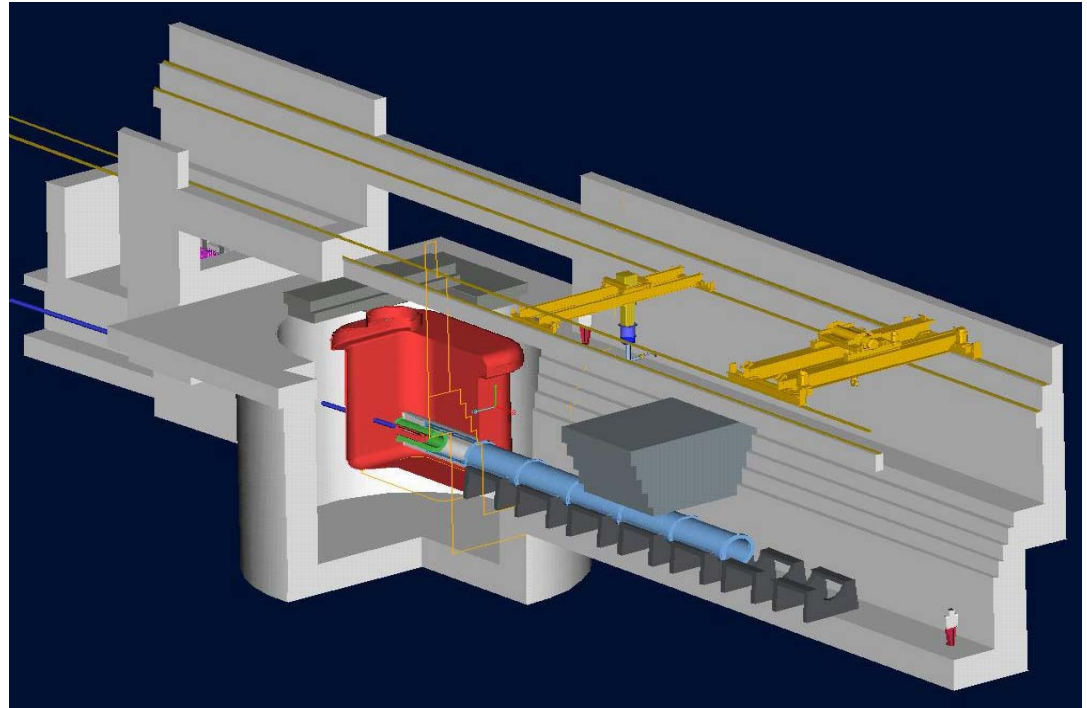

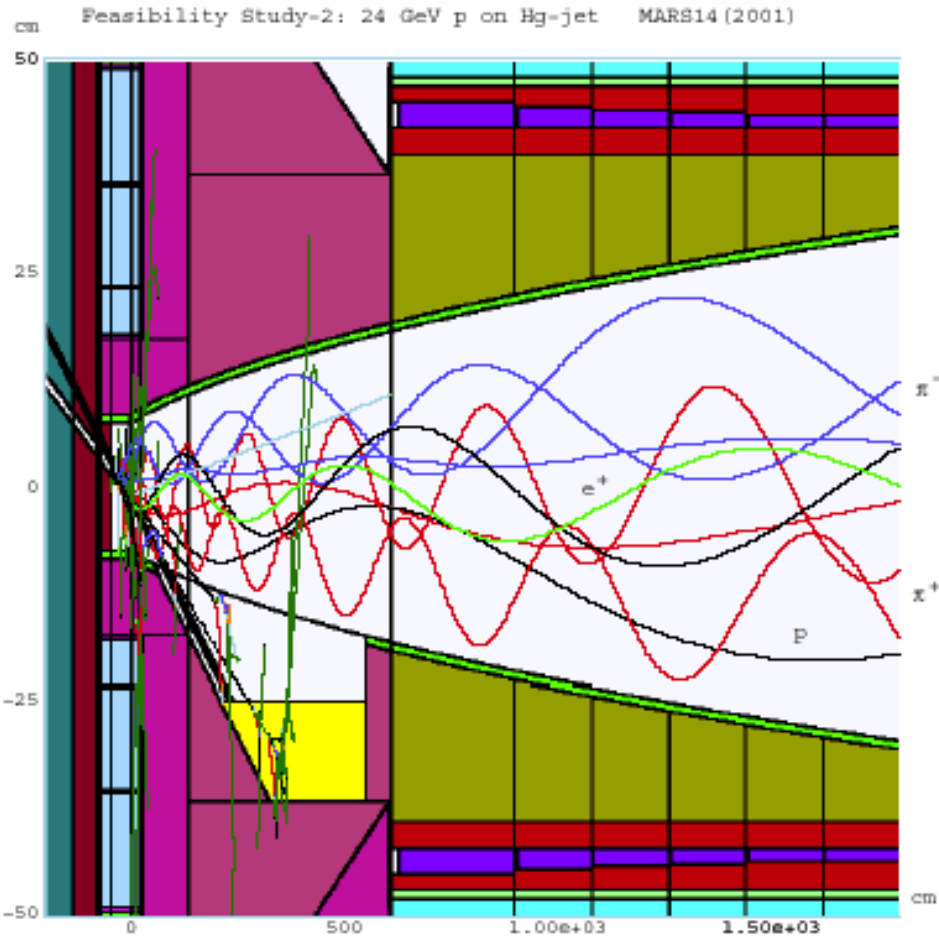

Tracks E>20 MeV



The Graphite Target is a Passively Cooled Rod-Like Structure

- It is coaxial with the proton beam, but 50 milliradians to the magnetic axis of the decay channel (*Mokhov*).
- Supported on graphite spokes.
- Radiates to a water-cooled stainless steel support tube (15 cm diam).

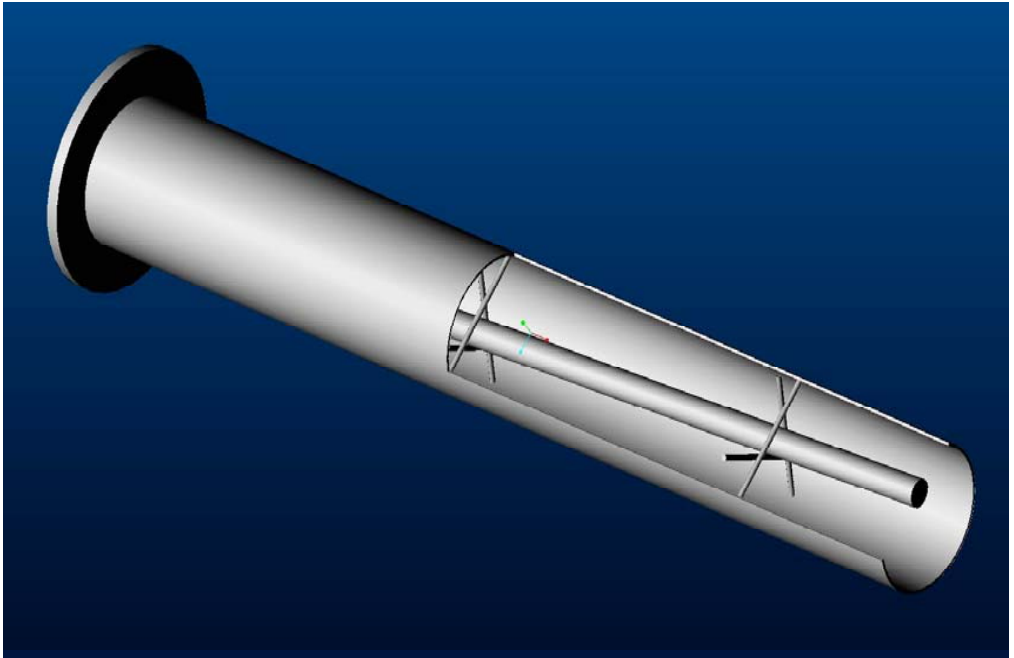

Optical Strain Sensor Technique Was Validated On Simple Graphite Rod Test



```
Max X +0.000e+00
at node 2001
Min X +0.000e+00
at node 2001
Max Y +0.000e+00
at node 2001
Min Y +0.000e+00
at node 2001
Max Z +0.000e+00
at node 2001
Min Z +0.000e+00
at node 2001
```

- WNR proton beam ($\sigma \sim 10$ mm radius) centered at $r = 4.9$ mm on 8.0 mm radius ATJ graphite rod
- Deflections amplified by 10^4
- Time slowed down by 1.5×10^3



Step: Ramped temperature rise, offset ~1/2 cm; orientation, NIGBOB-VIS, JAUMANN Increment 0: Step Time = 0.0

Deformed Var: U Deformation Scale Factor: +1.000e+04

Target – Sublimation

- At 2X the average power deposition, recession rate = 5 mm/d

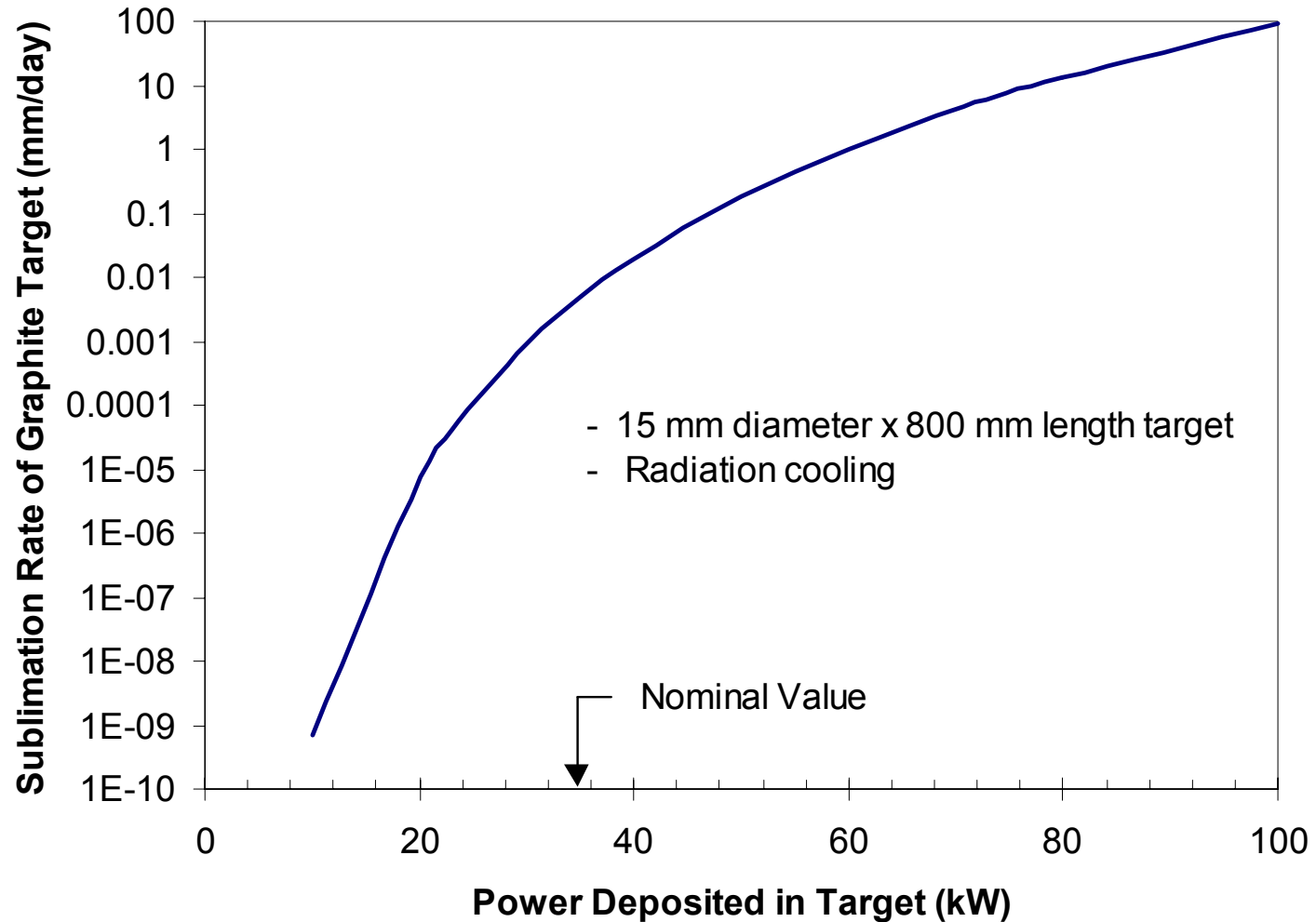

- **Other Issues**

- Examine irradiation database since radiation damage may be the life limiting mechanism.
- Evaluate using C-C composites which incorporate carbon fibers within a graphite matrix.
 - Improved thermal-mechanical properties and perhaps increased resistance to irradiation damage.

Neutronic Issues for the Neutrino Factory/Muon Collider Target/Capture Facility



- **Guess what transport code Mokhov used!**
- **π/μ production.**
- **Shielding and component lifetime.**
- **Heat levels.**

24 GeV proton beam (67 mrad) on a Hg jet (100 mrad)

Yield per proton at $z=36$ m:

- $\pi^+ + K^+ + \mu^+(0.05 < p < 0.8 \text{ GeV}/c) = 0.7108$
- $\pi^- + K^- + \mu^-(0.05 < p < 0.8 \text{ GeV}/c) = 0.6724$
- $\pi^+ + K^+(0.025 < E < 0.225 \text{ GeV}) = 0.0211$
- $\pi^- + K^-(0.025 < E < 0.225 \text{ GeV}) = 0.0192$
- $\mu^+(0.025 < E < 0.225 \text{ GeV}) = 0.3760$
- $\mu^-(0.025 < E < 0.225 \text{ GeV}) = 0.3704$

Table 2: Maximum radiation doses per 2×10^7 s/yr and 1 MW lifetimes of some components of the target system.

Component	Dose/yr (MGy)	Limit (MGy)	Life (yr)
Inner shielding	5×10^4	10^6	20
Hg containment	2×10^3	10^5	50
Hollow conductor	1×10^3	10^5	100
Superconducting coil	6	10^2	16

HEAT LOAD FOR 979.2 kW BEAM

- Mercury 119.181 kW
- 1-cm inner vessel 113.873 kW
- WCW shielding 489.118 kW
- Cu-water shielding 12.939 kW
- Resistive coils 9.910 kW
- SC1-SC2 1.256 kW
- SC3-SC13 1.385 kW

Component	P (kW)
Hg jet	96.492
Hg pool	22.689
FeCo	1.888
1-cm SS inner vessel	113.873
HC1	4.566
HC2	3.827
HC3	1.517
SC1-SC2	1.256
SC3-SC6	0.295
SC7	0.238
SC8-SC12	0.347
SC13 (18.6-36 m)	0.505
WCW ($z < 1.36$ m)	293.034
WCW ($1.36 < z < 6.1$ m)	196.084
CuW ($6.1 < z < 18.6$ m)	9.755
CuW ($18.6 < z < 36$ m)	3.184
Leakage	75.317
Others + "invisible"	147.333

- **A concept design for the neutrino factory *target support facility* was completed.**
- **Preliminary calculations demonstrate feasibility of using a passively cooled graphite target.**
- **The facility arrangement is based on work done for the SNS.**
- **A concept design for high field and low field solenoids demonstrates feasibility of resistive/superconducting magnets that meet field-on-axis requirements (NHMFL).**
- **Near term/longer term R&D is proposed to address thermal, mechanical, and radiation issues for graphite.**

- Complete MARS model of a neutrino factory target/capture system with a tilted proton beam was built and its performance studied for tilted solid carbon target and mercury jet
- Muon beam is formed: $\approx 0.37 \mu/p$ of each sign at 24 GeV on Hg
- Sophisticated shielding designed, nicely protects normal and SC coils, reducing radiation loads in the hottest spot of high-field SC coil to $F \approx 10^{18} \text{ cm}^{-2}\text{yr}^{-1}$, $P \approx 0.4 \text{ mW/g}$, and $D \approx 6 \text{ MGy/yr}$, providing ≥ 15 -year lifetime at 1 MW for all critical components
- Maximum residual dose rates exceed $1 \text{ kSv/hr} = 0.1 \text{ MRem/hr}$ after one day cooling, requiring remote control and robotics for inner parts of the system