

Cross Section of Coils & Shielding Vessels; Stresses & Deformations

Preliminary Results

Bob Weggel 7/5—7/26/2011

The inner radius of the bore tube of the inner shielding vessel should flare in proportion to the inverse square root of the magnetic field. The on-axis field decreases from $B_0 \approx 20$ T at $z \approx 0$ to $B_{15} \approx 1.5$ T at $z = 15$ meters, implying a radius ratio of 3.65. If the radius is 7.5 cm when $B = 20$ T, then the radius should be ~ 27.4 cm when $B = 1.5$ T. The I.R. of the bore tube plotted in Fig. 1 flares conically from $r = 7.6$ cm at $z = 0$, where $B \approx 19.6$ T, to $r = 18.2$ cm at $z = 6$ m.

On-Axis Field Profile and Bore-Tube Radius of "Layer6meters.xlsx"

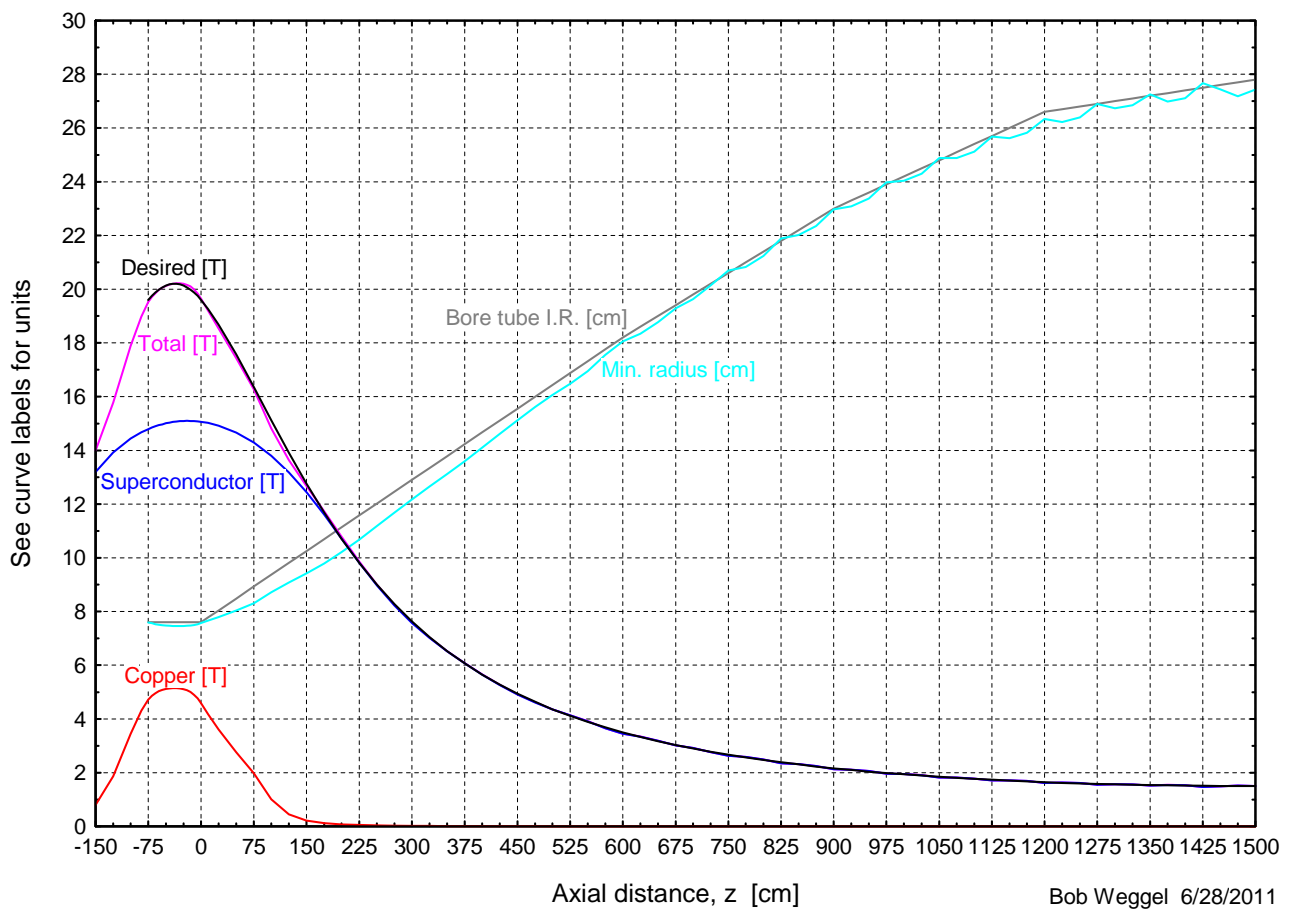

Fig. 1: Bore tube whose I.R. flares conically from $r = 7.6$ cm at $z =$ zero to $r = 18.2$ cm at 600 cm.

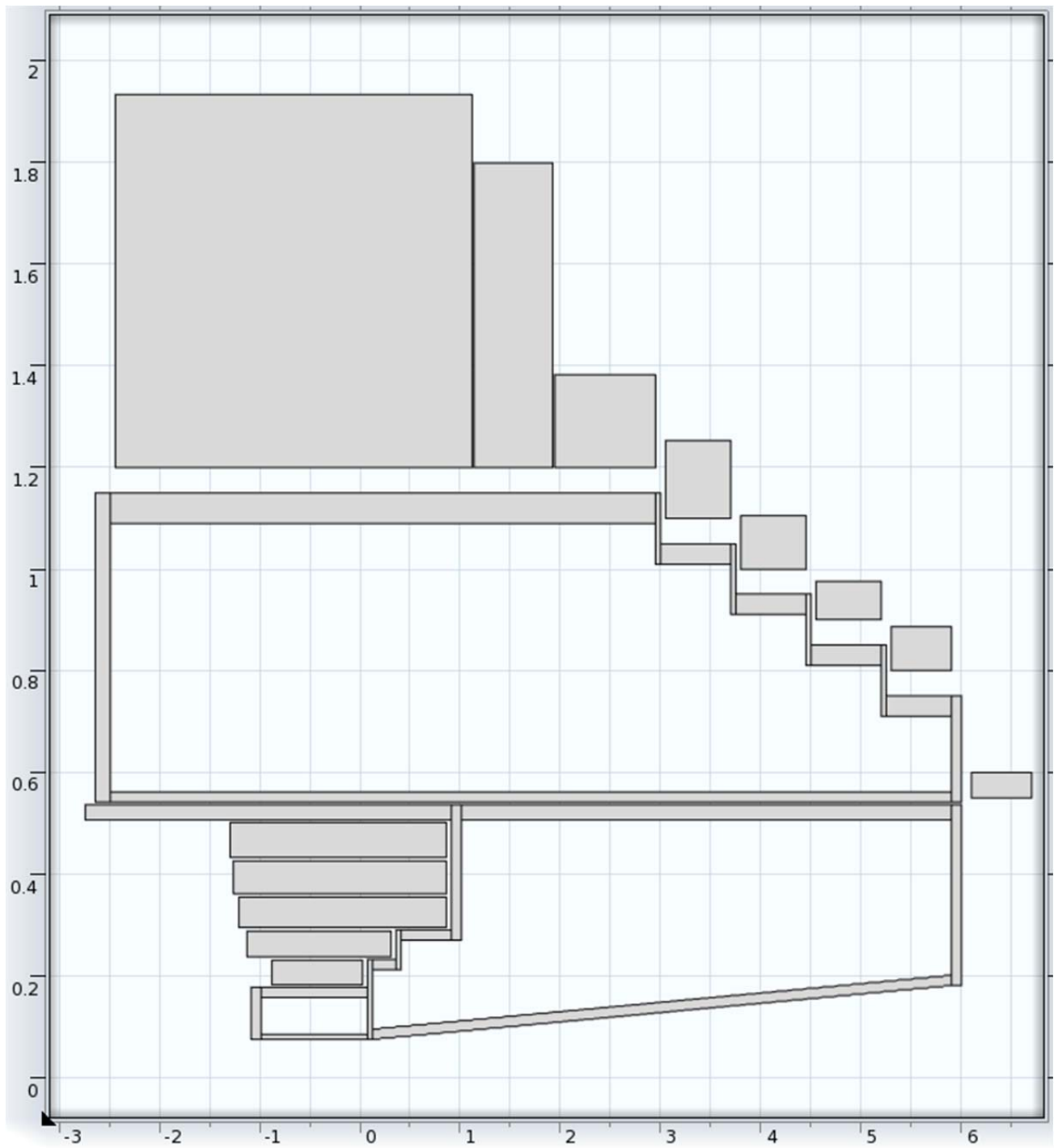

Fig. 2: Cross section (longitudinal axis compressed) of inner and outer shielding vessels of design "Shields50mm.mph", including the five resistive and upstream eight superconducting coils of Magnet Design IDS120h. Most annular disks ("flanges") between tubular members of different diameters are 50 mm thick. The largest end flange (outer, most-upstream flange) is 150 mm thick; the remaining four end flanges are 100 mm thick. Wall thicknesses of the outer vessel are 60 mm (upstream outer tube), 40 mm (other outer tubes) and 20 mm (inner tubes). Wall thicknesses of the inner vessel are 30 mm (outer tubes), 10mm (innermost tube) and 20 mm (all other tubes, including conical one).

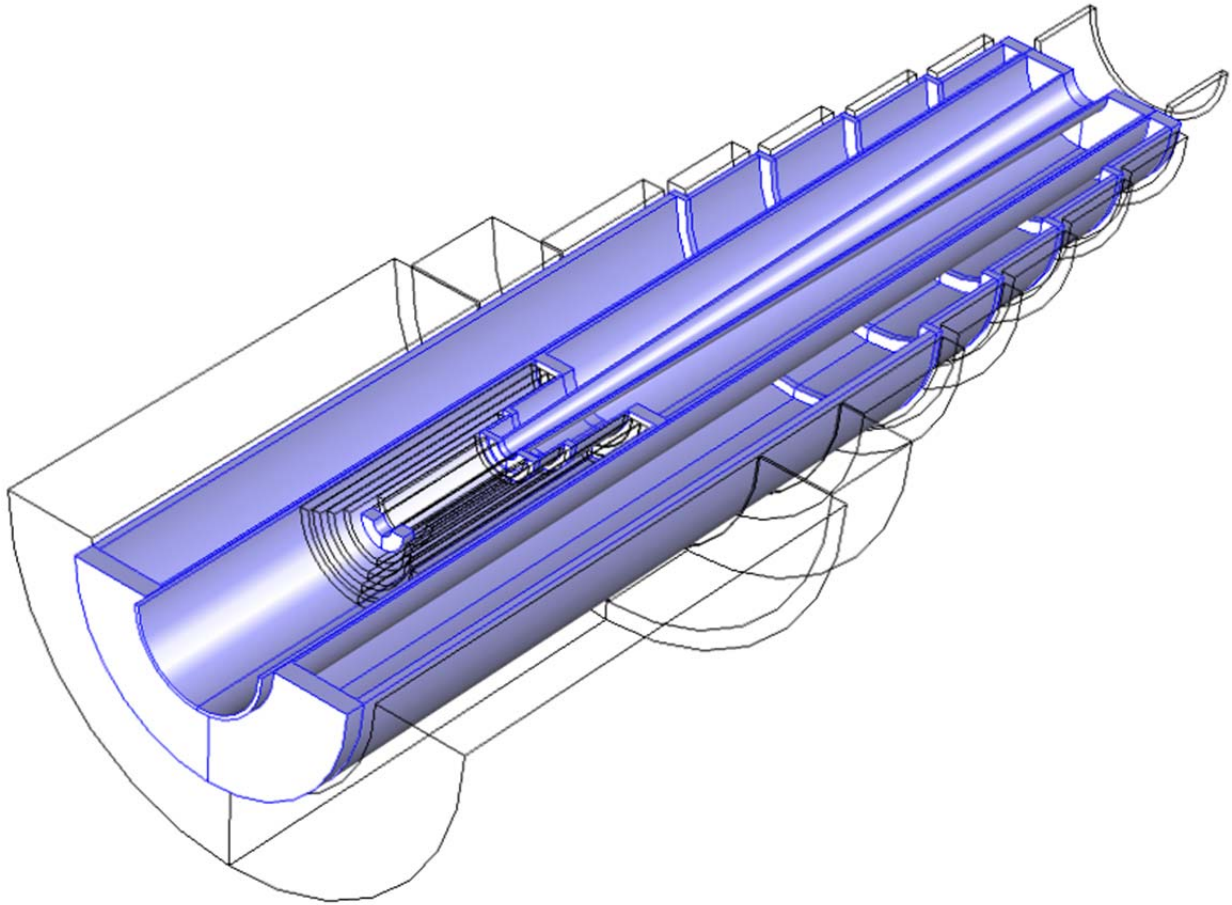

Fig. 3: Isometric view (longitudinal axis compressed) of inner and outer shielding vessels (blue) of design "Shields50mm.mph". Outlined are the five resistive and upstream eight superconducting coils of Magnet Design IDS120h. Most annular disks ("flanges") between tubular members of different diameters are 50 mm thick. The largest end flange (outer, most-upstream flange) is 150 mm thick; the remaining four end flanges are 100 mm thick. Wall thicknesses of the outer vessel are 60 mm (upstream outer tube), 40 mm (other outer tubes) and 20 mm (inner tubes). Wall thicknesses of the inner vessel are 30 mm (outer tubes), 10 mm (upstream inner tube) and 20 mm (all other tubes, including conical one). All members are of structural steel, with two exceptions: The two most-upstream tubes within the bore of the resistive magnet are of tungsten, for stiffness and shielding effectiveness.

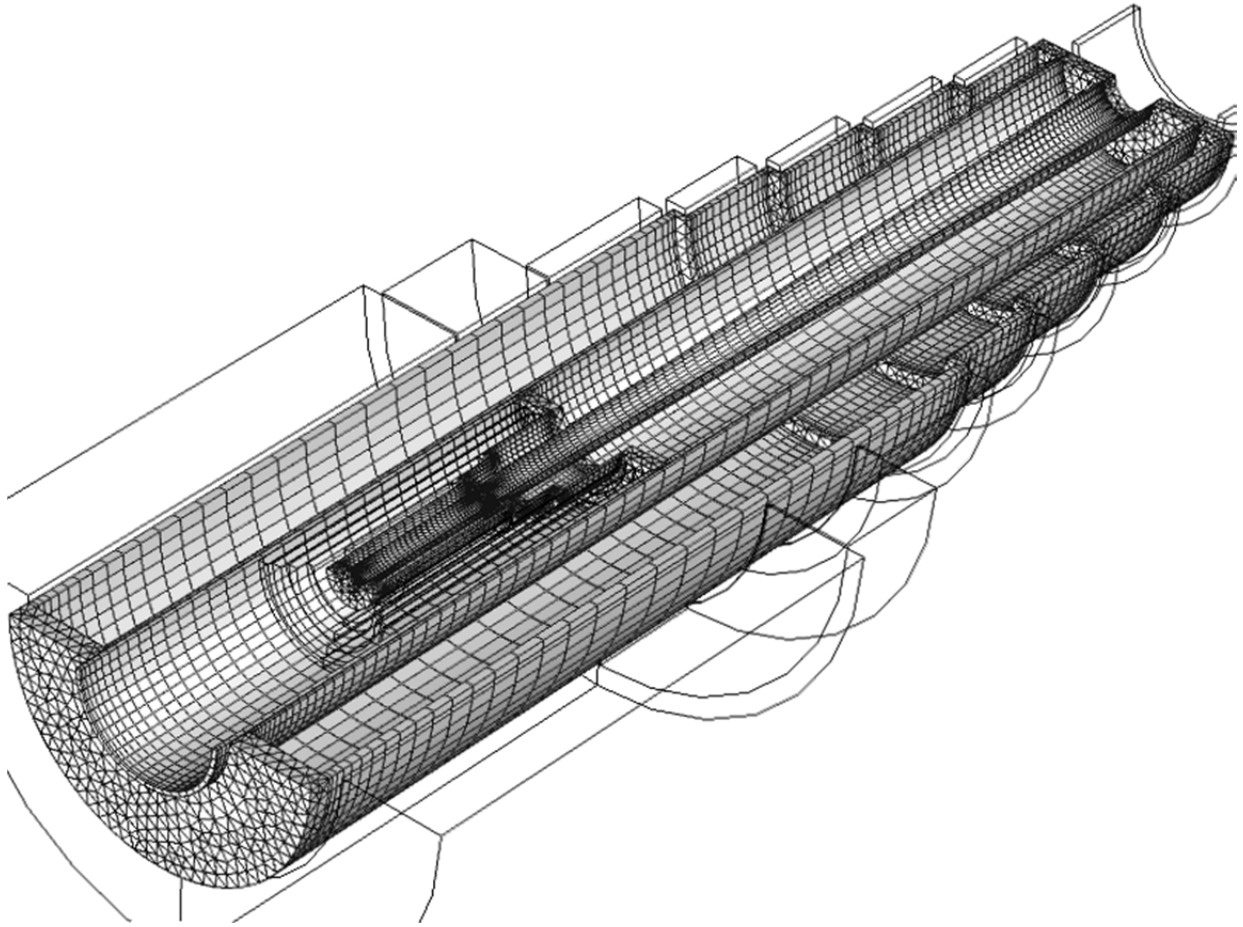

Fig. 4: Finite-element mesh: Cylindrical members use hexahedral elements, user-mapped to give the highest-quality mesh in regions where stresses and stress gradients are highest--where tubular members mate with annular disks. Annular disks use computer-generated tetrahedral elements. Total number of elements = 26,900; number of degrees of freedom = 470,253.

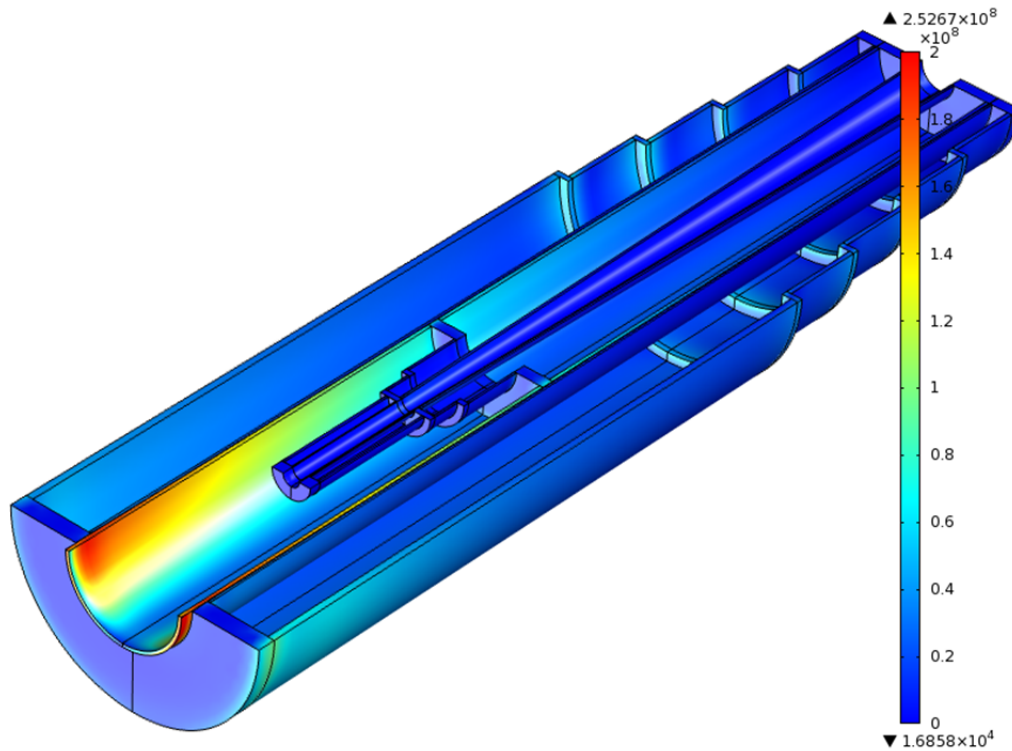

Fig. 5: Von Mises stress with both vessels fixed only at upstream end. Maximum stress = 253 MPa.

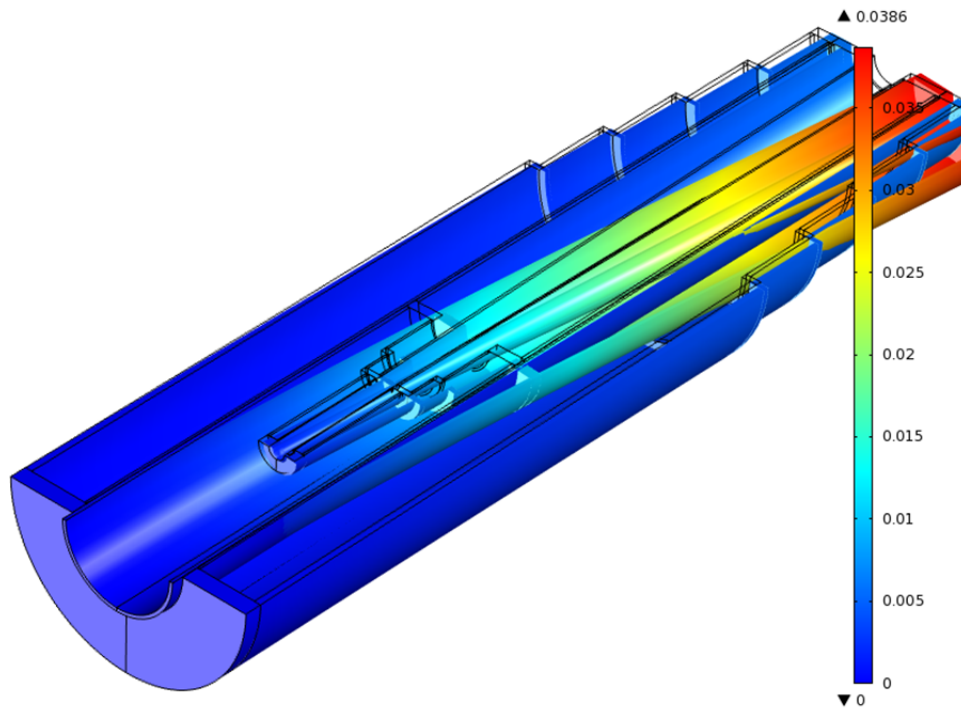

Fig. 6: Total deformation, magnified 20-fold, with both vessels fixed only at upstream end. Maximum deformation is 39 mm.

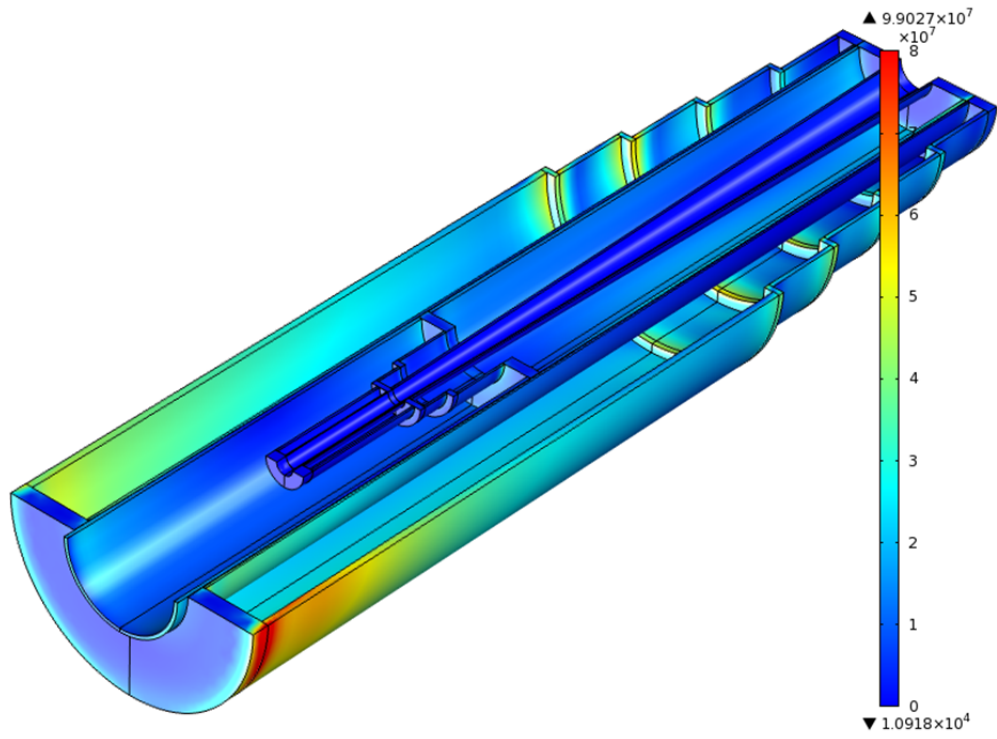

Fig. 7: Von Mises stress with inner vessel fixed at both ends. Maximum stress = 99 MPa.

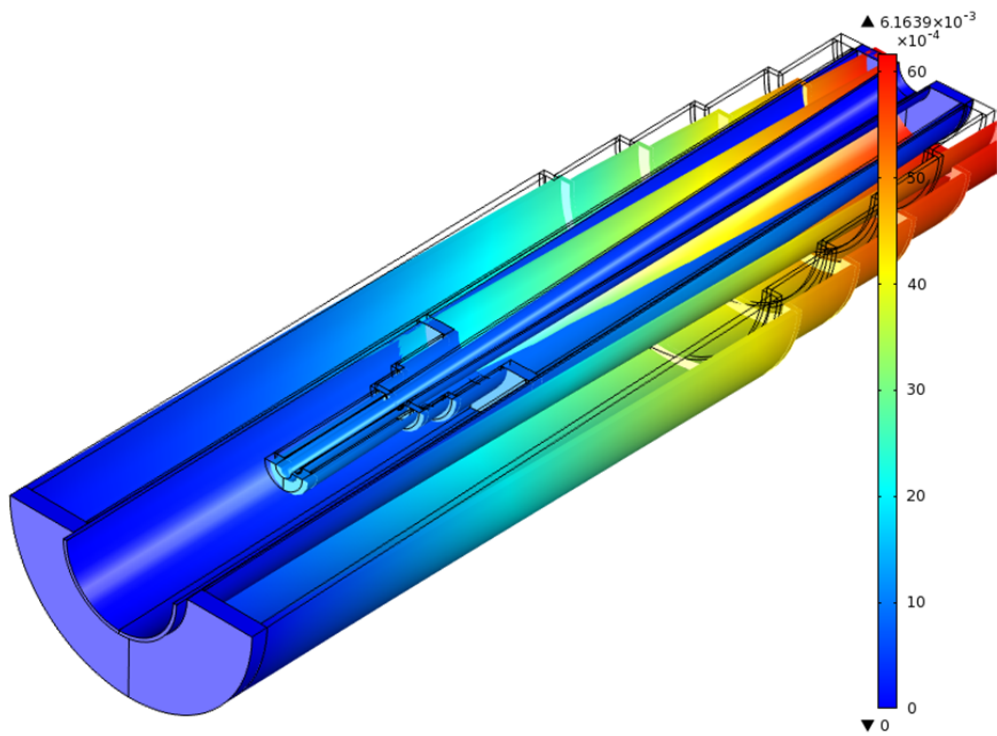

Fig. 8: Deformation, magnified 40-fold, with inner vessel fixed at both ends. Maximum deformation = 6.2 mm.

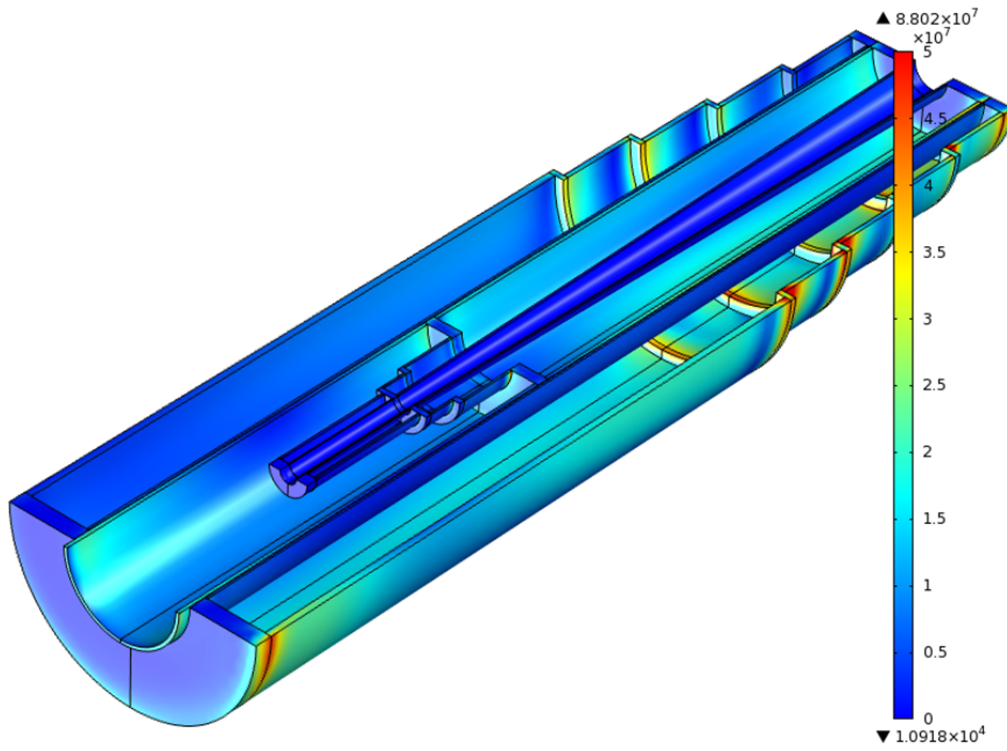

Fig. 9: Von Mises stress with both vessels fixed at both ends. Maximum stress = 88 MPa.

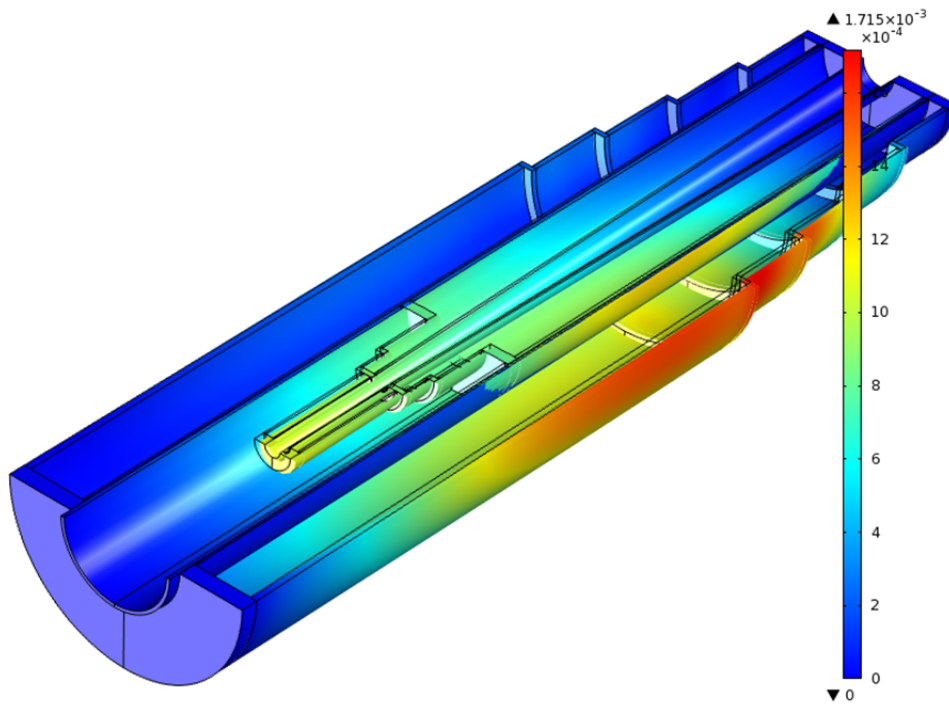

Fig. 10: Deformation, magnified 50-fold, with both vessels fixed at both ends. Maximum deformation = 1.7 mm.